



---

**POMPE E MOTORI A PISTONI ASSIALI  
AD ASSE INCLINATO**

***BENT AXIS AXIAL PISTON  
PUMPS AND MOTORS***

**AXIALKOLBENPUMPEN-MOTOREN**

**HP BA  
110**

398SBA0033A01

# HP BA 110

## MOTORI IDRAULICI A CILINDRATA VARIABILE AD ASSE INCLINATO VARIABLE-DISPLACEMENT AXIAL PISTON MOTORS AXIALKOLBENVERSTELLMOTOREN

Il sistema è stato progettato in modo da ottenere un elevato angolo di inclinazione dei pompanti rispetto all'asse dell'albero uscente. Rispetto a motori a piatto inclinato che raggiungono i 18° l'angolo di inclinazione nella versione Bent Axis raggiunge i 25°.

Tale geometria permette:

- elevata coppia di spunto
- elevato range di variazione della cilindrata
- elevata efficienza volumetrica e meccanica
- elevata velocità massima
- elevate pressioni massime

Il motore in oggetto è provvisto di valvola di scambio di serie con strozzatore di diametro di 1.7 mm. La variazione della cilindrata da massima a minima avviene tramite pilotaggio idraulico ad alta o a bassa pressione oppure tramite comando elettrico in funzione delle richieste del cliente. Questa configurazione permette un ampio range di variazione della cilindrata fino ad un minimo del 30% rispetto alla massima. Nella versione a comando elettrico l'elettrovalvola ha un range di funzionamento in corrente di  $\pm 10\%$  del valore nominale.

*The system has been designed in order to obtain a high angle of inclination of the pumps with respect to the axle of the outgoing shaft.*

*With respect to motors with a tilted plate which reach 18°, the angle of inclination in the Bent Axis version reaches 25°.*

*This geometry allows:*

- high static torque
- high range of displacement variation
- high volumetric and mechanical efficiency
- high maximum reachable speed
- high maximum pressures

*This motor is equipped with a standard exchange valve with choke diameter 1.7 mm.*

*Displacement is varied from maximum to minimum by means of a high or low pressure hydraulic control or by an electric control, as requested by the customer.*

*This configuration allows an ample range of variation of displacement down to a minimum of 30% with respect to the maximum.*

Die Schrägachsenmotoren wurden so konstruiert, daß sie einen größeren Schwenkwinkel von 25° ermöglichen als bei den Schrägscheibeneinheiten mit 18°. Dies ermöglicht.

- Höheres Anlaufmoment
- Großer Stellbereich des Schluckvolumens
- Gute mechanisch hydraulische und volumetrische Wirkungsgrade
- Hohe Enddrehzahl
- Hohe Betriebsdrücke

Die Motoren sind mit einem Spülventil mit Ausspeisedüse  $\varnothing 1,7\text{mm}$  bestückt.

Die Verstellung des Schluckvolumens der Motoren geschieht durch hydraulische Vorsteuerung, entweder durch Hoch- oder Niederdruck oder durch elektrische Ansteuerung je nach Kundenwunsch. Dies erlaubt einen großen Stellbereich von Vmax bis 30% von Vmax.

# HP BA 110

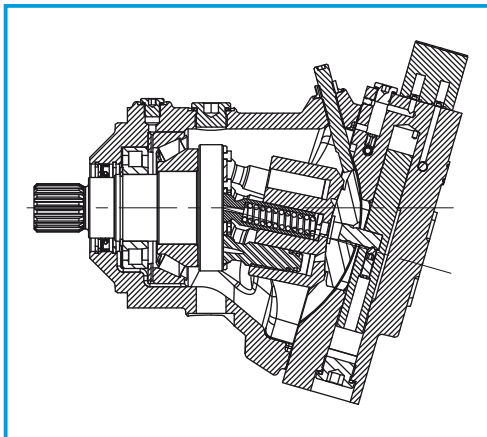

### DATI TECNICI TECHNICAL DATA TECHNISCHE MERKMALE

GRUPPO GROUP BAUREIHE	CILINDRATA TEORICA NOMINAL DISPLACEMENT FORDERVOLUMEN (TM)		OSCILLANTE SWASHPLATE SCHWENKWINKEL °	PRESSIONE PRESSURE DRUCK		VELOCITÀ DI ROTAZIONE SPEED DREHZAHL			MASSA WEIGHT GEWICHT					
	cm <sup>3</sup>	in <sup>3</sup>		CONTINUA CONTINUOUS DAUER	INTERMITTENTE INTERMITTENT INTERMITTIERENDER	PICCO PEAK SPITZEN	MAX (max V)	MAX (min V)	MIN	kg	lbs			
HP BA	110	6.65	26	350	5075	400	5800	450	6525	2900	4500	500	45	99



**DIMENSIONI  
SIZE  
ABMESSUNGEN**

**HP BA 110**

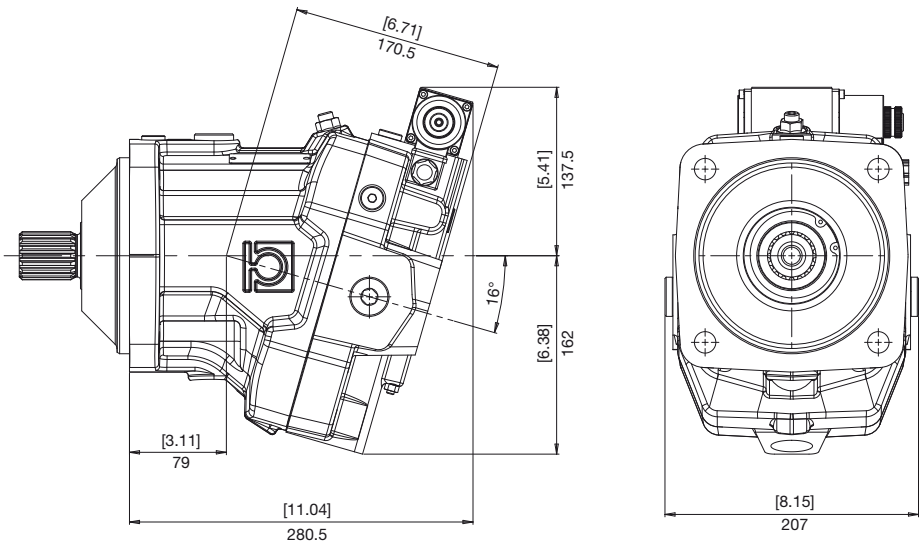

**FLANGE  
FLANGES  
FLANSCH**

**HP BA 110**

**I** ISO 4 FORI  
ISO 4 HOLES  
ISO 4 BOHRUNGEN

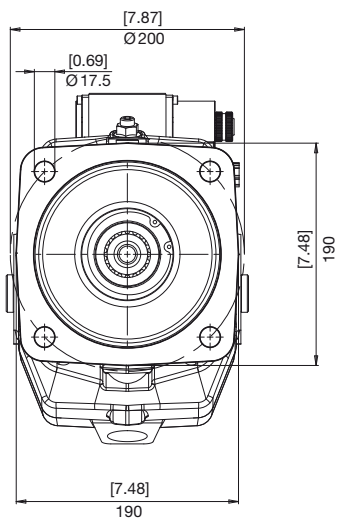
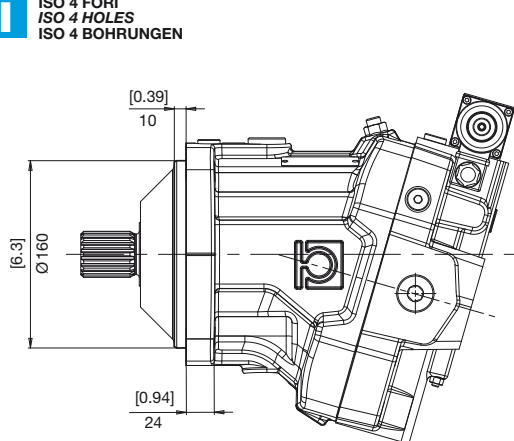

**ESTREMITÀ ALBERI  
SPLINE SHAFTS  
WELLENPROFILE**

**B** COPPIA MAX  
MAX TORQUE  
MAX DREHMOMENT 1310 N•m

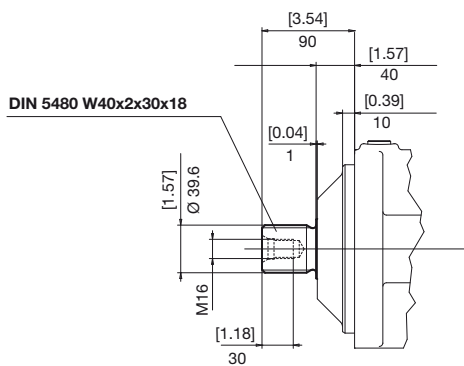

**D** COPPIA MAX  
MAX TORQUE  
MAX DREHMOMENT 1980 N•m

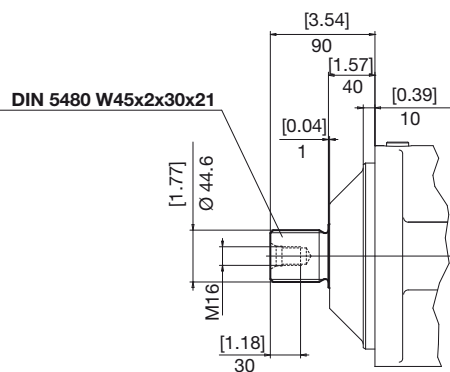

**POSIZIONE BOCHE**  
**POSITION OF PORTS**  
**ANSCHLUSSPOSITION**

**HP BA 110**

**P** POSTERIORI  
REAR  
HINTEN

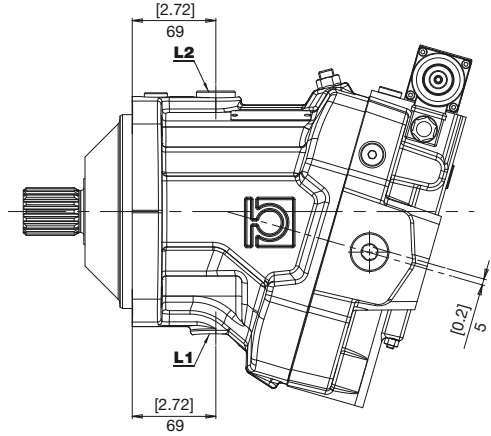
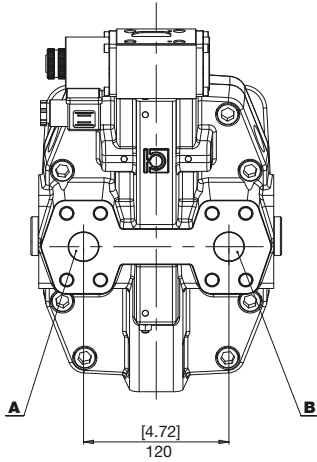

**L** LATERALI CONTRAPPOSTE  
OPPOSITE SIDEWAYS  
BEIDSEITIG

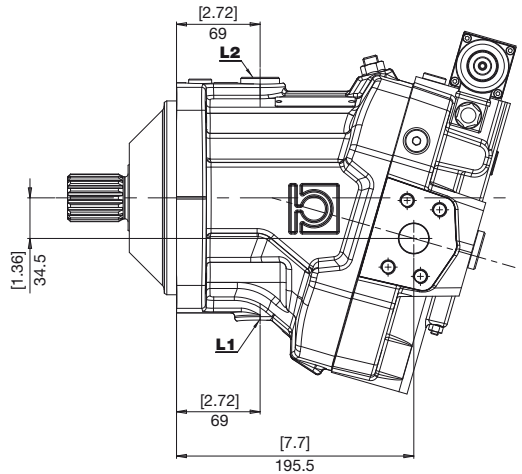
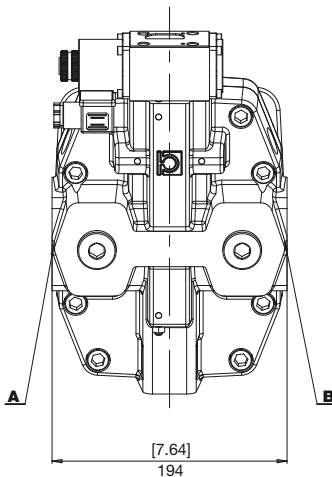

**BOCCHIE  
PORTS  
ANSCHLÜSSE**

**HP BA 110**

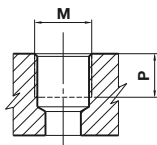

TIPO TYPE TYP	M	P	
		Nm	mm in
<b>G2</b>	Port ISO 1179-1 - G1/4	17	8 0,31
<b>G6</b>	Port ISO 1179-1 - G3/4	90	19 0,75
<b>G7</b>	Port ISO 1179-1 - G1	160	19 0,75

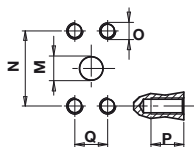

TIPO TYPE TYP	M		N		P		Q		O	
	mm	in	mm	in	mm	in	mm	in	M12	Nm
<b>N7</b>	25	1	57,15	2,25	27,76	1,09	20	0,79	M12	70

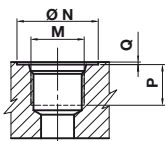

TIPO TYPE TYP	DIMENSIONE SIZE GRÖSSE	N		P		Q		M	
		mm	in	mm	in	mm	in	Nm	
<b>U2</b>	1/4"	20	0,79	12	0,47	0,3	0,01	Port ISO 11926-1-7/16-20	17
<b>U6</b>	3/4"	41	1,61	20	0,79	0,3	0,01	Port ISO 11926-1-1/16-12	90
<b>U7</b>	1"	49	1,93	18	0,70	0,3	0,01	Port ISO 11926-1-5/16-12	160

**COMBINAZIONI  
COMBINATIONS  
KOMBINATIONEN**

TIPO TYPE TYP	A - B INGRESSO/USCITA INLET/ OUTLET EINGANG/AUSGANG	L1 - L2 DRENAGGIO DRAIN LECKÖLANSCHLUSS	a - b - x PILOTAGGIO PILOT STEUERDRUCK
<b>G</b>	G7	G6	G2
<b>U</b>	U7	U6	U2
<b>N</b>	N7	G6	G2
<b>M</b>	N7	U6	U2

**COMANDI  
CONTROLS  
STEUERUNGEN**

**HP BA 110**

**E F**  
12 V 24 V

**ELETTRICO A 2 POSIZIONI  
ELECTRICAL, 2-POSITION  
ELEKTRISCH, 2 STELLUNGEN**

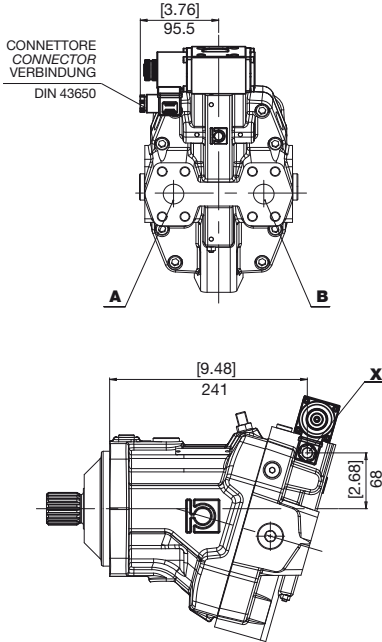

INGRESSO INLET EINGANG	ROTAZIONE DIRECTION DREHRICHTUNG		
A	SINISTRA LEFT LINKS		
B	DESTRA RIGHT RECHTS	<b>X</b>	Elettrovalvola Solenoid Valve Magnetventil

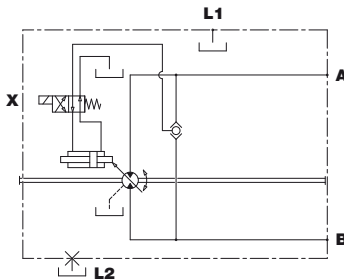

**H**

**IDRAULICO DIRETTO A 2 POSIZIONI  
DIRECT HYDRAULIC, 2-POSITION  
HYDRAULISCH DIREKT, 2 STELLUNGEN**

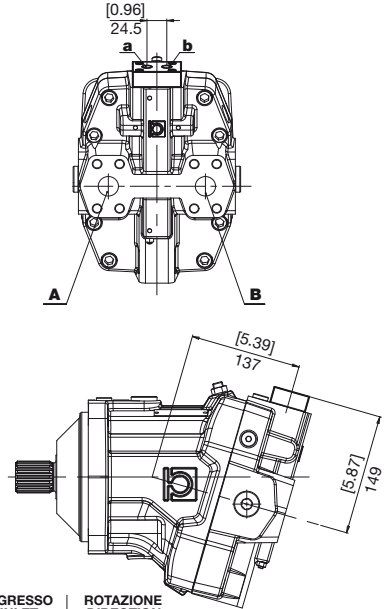

INGRESSO INLET EINGANG	ROTAZIONE DIRECTION DREHRICHTUNG		
A	SINISTRA LEFT LINKS		
B	DESTRA RIGHT RECHTS	<b>a</b> (cm <sup>3</sup> min) <b>b</b> (cm <sup>3</sup> max)	Comando idraulico diretto Direct hydraulic control Hydraulische Direktsteuerung

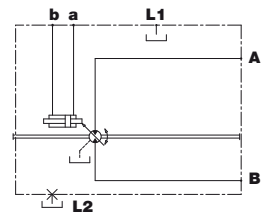
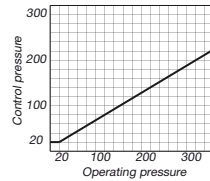

**K** IDRAULICO A 2 POSIZIONI A BASSA PRESSIONE  
HYDRAULIC, 2-POSITION - LOW PRESSURE  
HYDRAULISCH, 2 STELLUNGEN - NIEDERDRUCK

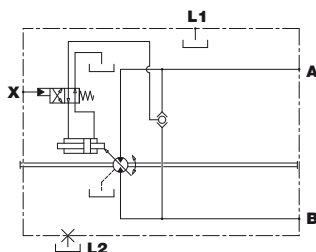
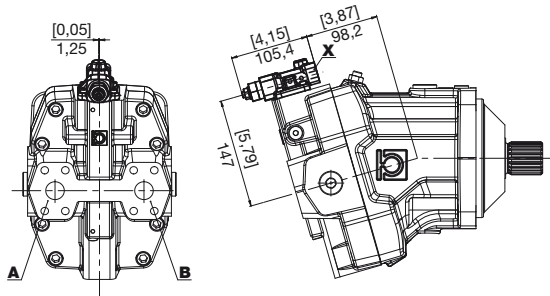

INGRESSO INLET EINGANG	ROTAZIONE DIRECTION DREHRICHTUNG
A	SINISTRA LEFT LINKS
B	DESTRA RIGHT RECHTS

**X** Pilotaggio  
Pilot  
Steuerdruck

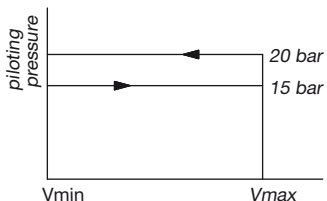

Normalmente il motore é in cilindrata massima. Applicando una pressione esterna sul pilotaggio si ottiene la variazione di cilindrata alla minima.

Per una corretta variazione della cilindrata attenersi ai valori di pressione di pilotaggio riportati nel diagramma.

The motor is usually at maximum displacement. By applying external pressure on pilot "X" the displacement is changed to a minimum.

To correctly change displacement, follow the pilot pressure values as shown in the chart.

Normalerweise hat der Motor das maximale Schluckvolumen. Durch Anwendung eines äußeren Drucks auf den Steuerdruck erzielt man die Verstellung auf das Mindest-Sluckvolumen. Zur korrekten Änderung des Schluckvolumens wird empfohlen, die im Diagramm dargestellten Steuerdruckwerte zu beachten.



**A** IDRAULICO AUTOMATICO (ON/OFF)  
HYDRAULIC AUTOMATIC (ON/OFF)  
HYDRAULISCH AUTOMATISCHE (ON/OFF)

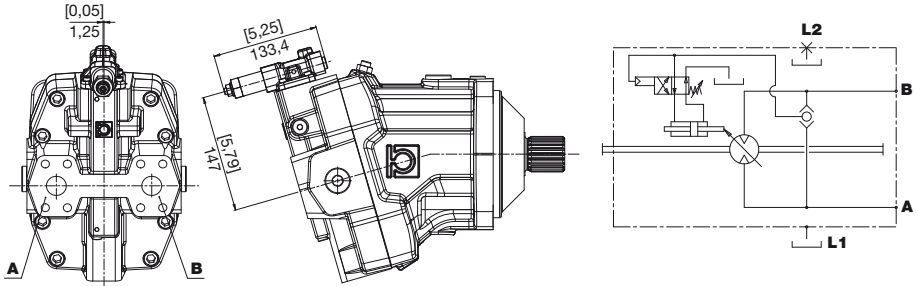

INGRESSO INLET EINGANG	ROTAZIONE DIRECTION DREHRICHTUNG
A	SINISTRA LEFT LINKS
B	DESTRA RIGHT RECHTS

**Pt** Pressione di taratura  
(secondo specifica cliente)  
Relief pressure  
(according to client specification)  
Kalibrierdrucks  
(Kunden Spezifische)

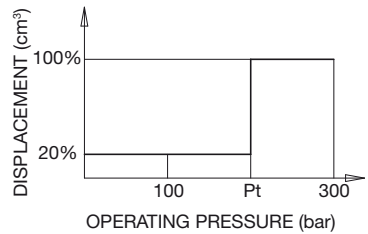

**O** **V**  
12 V 24 V

ELETRICO PROPORZIONALE RETROAZIONATO  
ELECTRICAL PROPORTIONAL FEEDBACK CONTROL  
ELEKTRISCH PROPORTIONALSTEUERUNG, RÜCKGEFÜHRT

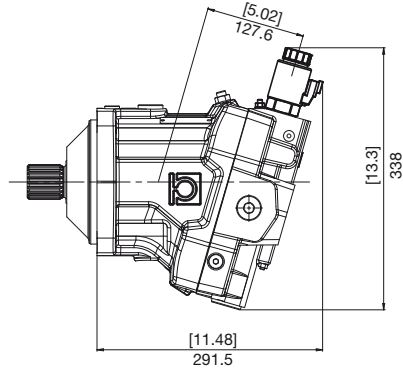
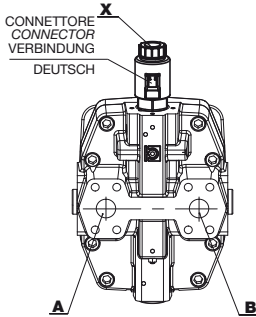

**O**

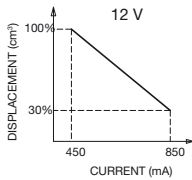

**V**

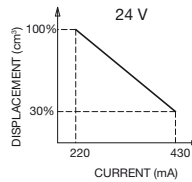

INGRESSO INLET EINGANG	ROTAZIONE DIRECTION DREHRICHTUNG
A	SINISTRA LEFT LINKS
B	DESTRA RIGHT RECHTS

**X** Elettrovalvola  
Solenoid Valve  
Magnetventil

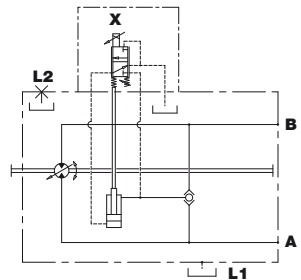

**G**

IDRAULICO PROPORZIONALE  
HYDRAULIC PROPORZIONAL  
HYDRAULISCH PROPORZIONAL

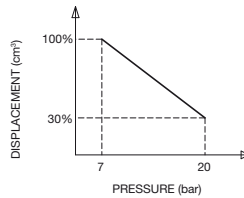
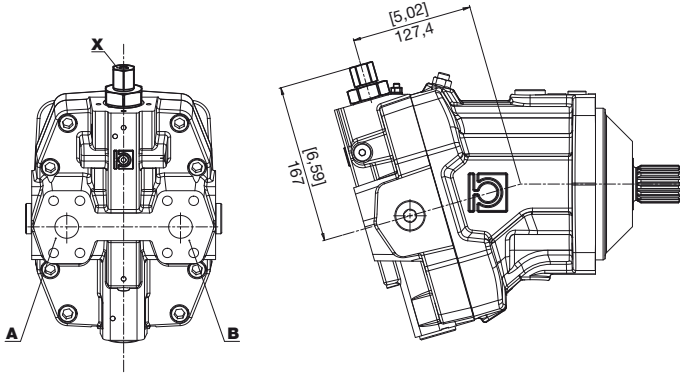

INGRESSO INLET EINGANG	ROTAZIONE DIRECTION DREHRICHTUNG
A	SINISTRA LEFT LINKS
B	DESTRA RIGHT RECHTS

**X** Pilotaggio  
Pilot  
Steuerdruck

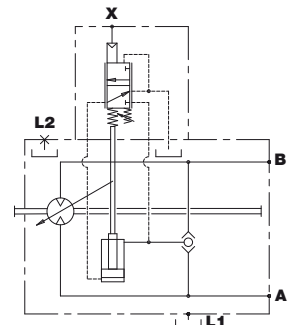

**V** VALVOLA DI FLUSSAGGIO (5 - 7 l/min)  
FLUSHING AND BOOST VALVE (5- 7 l/min)  
SPUL- UND SPEISEDRUCKVENTIL (5 - 7 l/min)

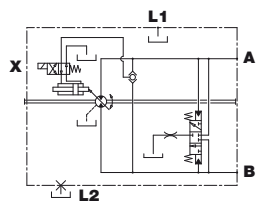
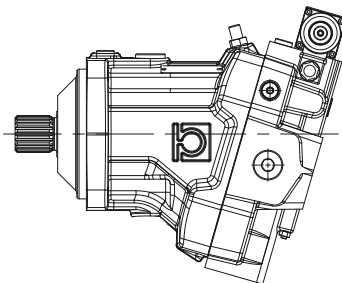
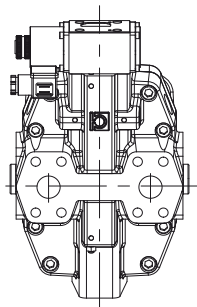



**ISTRUZIONI PER L'ORDINAZIONE**  
**ORDERING INSTRUCTIONS**  
**BESTELLANLEITUNG**

**HP BA 110**



**PRODOTTO**  
**PRODUCT**  
**PRODUKT**  
BA - Motori a cilindrata variabile  
BA - *Variable-displacement motors*  
BA - Schrägachsen-Verstellmotor

**CILINDRATA STANDARD**  
**STANDARD DISPLACEMENT**  
**FÖRDERVOLUMEN STANDARD**  
110

**CILINDRATA MINIMA**  
**MIN. DISPLACEMENT**  
**MIN. SCHLUCKVOLUMEN**

**FLANGIA**  
**FLANGE**  
**FLANSCH**  
I - ISO 4 fori  
I - *ISO 4 holes*  
I - ISO 4 Bohrungen

**ESTREMITÀ ALBERO**  
**SHAFT PROFIL**  
**WELLENENDE**  
B - DIN 5480  
W40x2x30x18  
D - DIN 5480  
W45x2x30x21

**BOCCHIE**  
**PORTS**  
**ANSCHLÜSSE**  
Vedi tabella  
See chart  
Siehe Tabelle

**ESECUZIONI SPECIALI**  
**SPECIAL VERSIONS**  
**SONDERBAUARTEN**

**ACCESSORI**  
**ACCESSORIES**  
**ZUBEHÖR**  
V - valvola di flussaggio  
V - *flushing and boost valve*  
V - Spül- und speisedruckventil

**COMANDI**  
**CONTROLS**  
**STEUERUNGE**  
A - Idrraulico automatico (ON/OFF)  
E - Elettrico (12 V) a 2 posizioni  
F - Elettrico (24 V) a 2 posizioni  
G - Idrraulico proporzionale  
H - Idrraulico diretto a 2 posizioni  
K - Idrraulico a 2 posizioni a bassa pressione  
O - Elettrico proporzionale retroazionato 12 V  
V - Elettrico proporzionale retroazionato 24 V  
  
A - *hydraulic automatic (ON/OFF)*  
E - *12 V electrical, 2-position*  
F - *24 V electrical, 2-position*  
G - *Hydraulic proportional*  
H - *Direct hydraulic, 2-position*  
K - *Hydraulic, 2-position - low pressure*  
O - *Electrical proportional feedback control 12V*  
V - *Electrical proportional feedback control 24V*  
  
A - *Hydraulisch automatische (ON/OFF)*  
E - *Elektrisch (12 V), 2 Stellungen*  
F - *Elektrisch (24 V), 2 Stellungen*  
G - *Hydraulisch proportional*  
H - *Hydraulisch direkt, 2 Stellungen*  
K - *Hydraulisch, 2 Stellungen, niederdruck*  
O - *Elektrisch proportionalsteuerung, rückgeführt 12 V*  
V - *Elektrisch proportionalsteuerung, rückgeführt 24 V*

**POSIZIONE BOCCHIE**  
**POSITION OF PORTS**  
**ANSCHLUSSPOSITION**  
L - Laterali contrapposte  
P - Posteriori  
L - *Opposite sideways*  
P - *Rear*  
L - *Beidseitig*  
P - *Hinten*