

RF0500DO Compensated flow rate regulator ON-OFF
with excess on unloading
Interface IBW0500

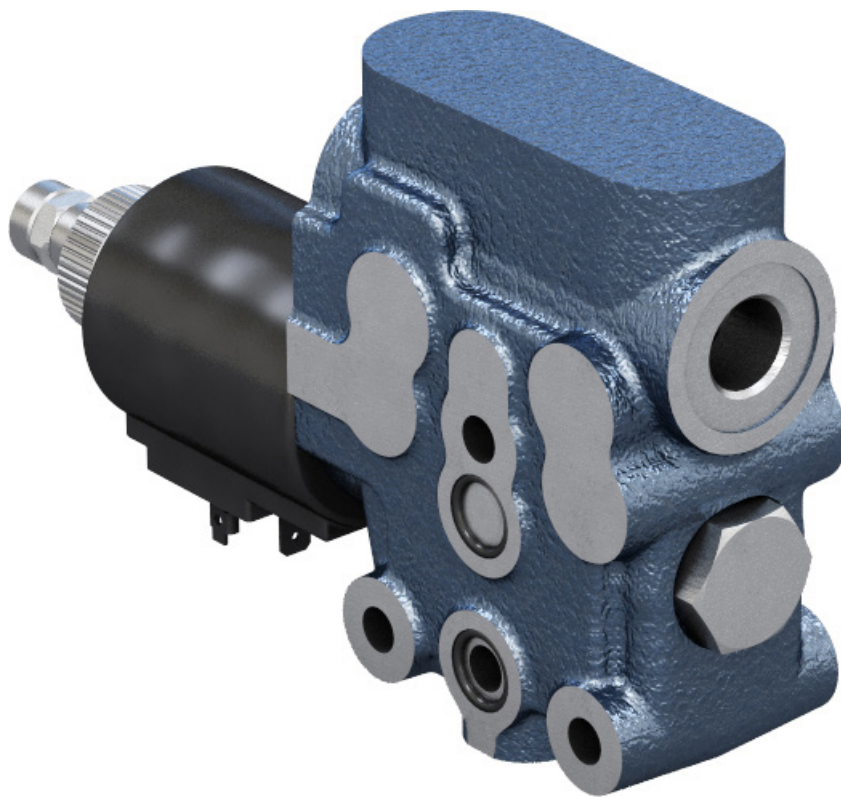

Before use, carefully read the GENERAL INSTRUCTIONS FOR USE OF DIRECTIONAL CONTROL VALVES

Nominal flow	50 l/min 13.2 US gpm
Nominal pressure	250 bar 3625 psi
Maximum tank pressure	50 bar 725 psi
Regulated flow rate	40 l/min - 10.56 US gpm 20 l/min - 5.28 US gpm
Temperature range	-20°C +85°C NBR seals (max peak +100°C) -20°C + 130°C HNBR seals
Oil viscosity	from 15 mm²/s to 90 mm²/s (15 cSt to 90 cSt)
Fluid	Hydraulic fluids as defined in ISO 6743-4 standard
Weight	2.6 kg 5.73 lb
Interface	IBW0500

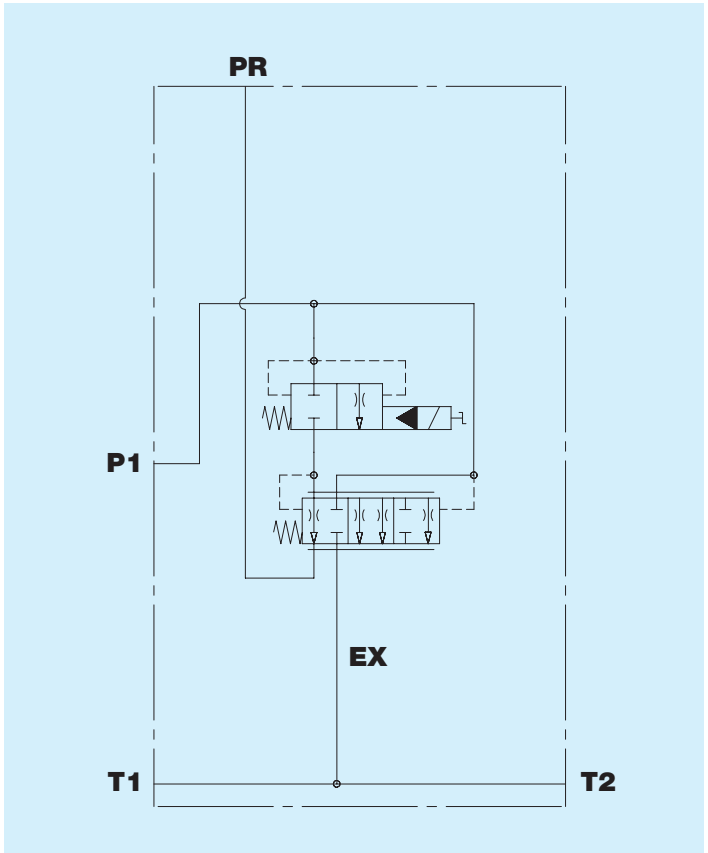

Dimensions

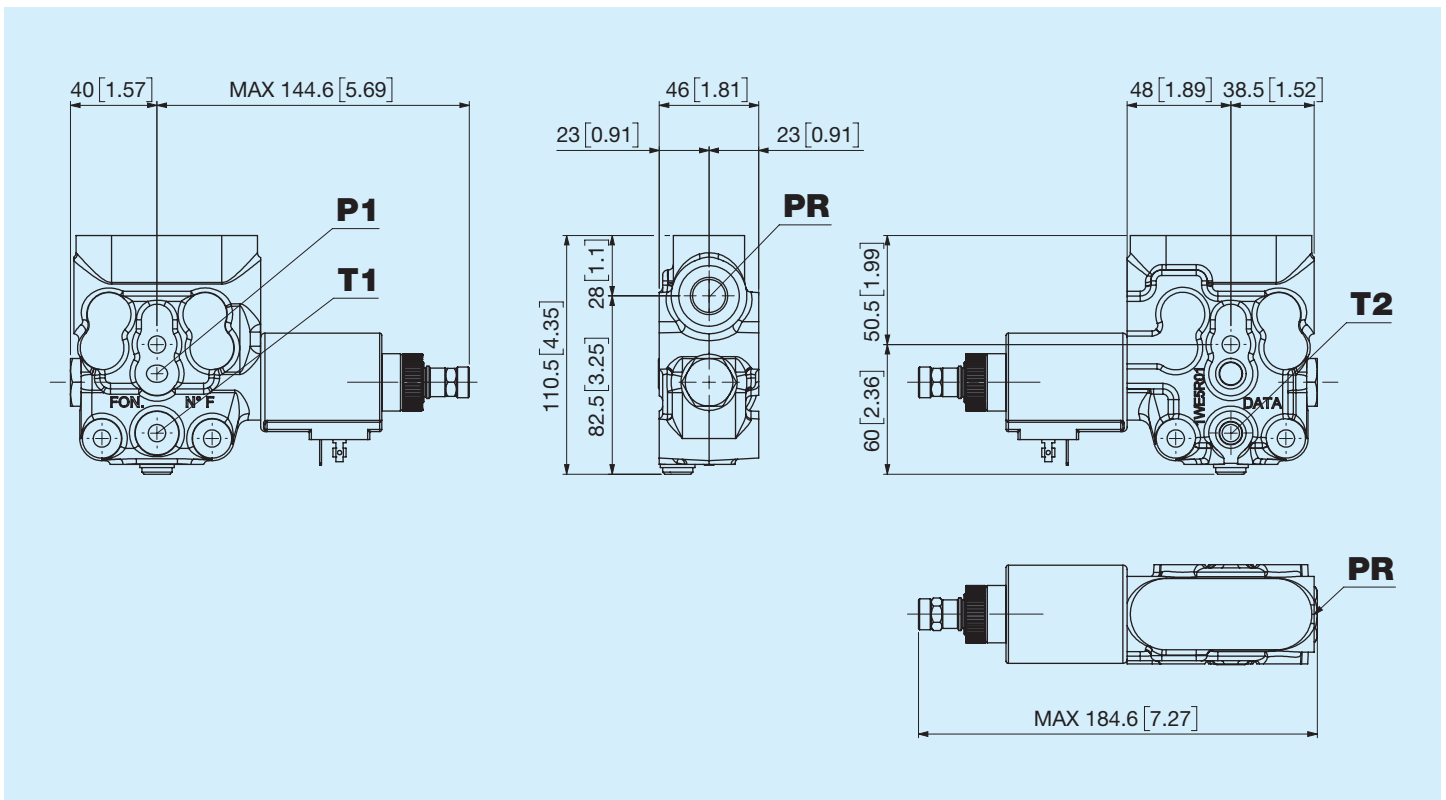

2-way priority cursor N.C.

ΔP P - EX/T

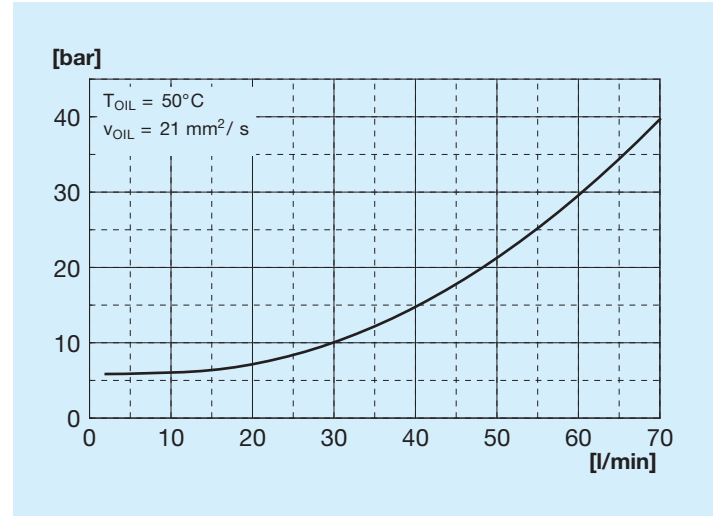
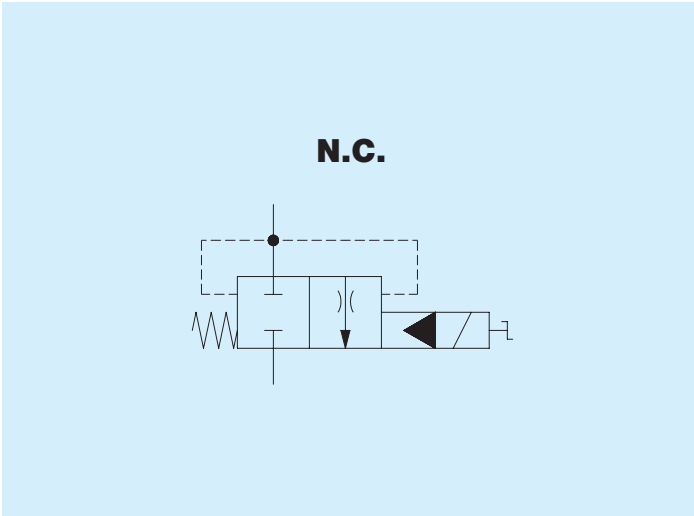

ΔP P - PR cursor 0-20 l/min

Flow rate P - PR cursor 0-20 l/min

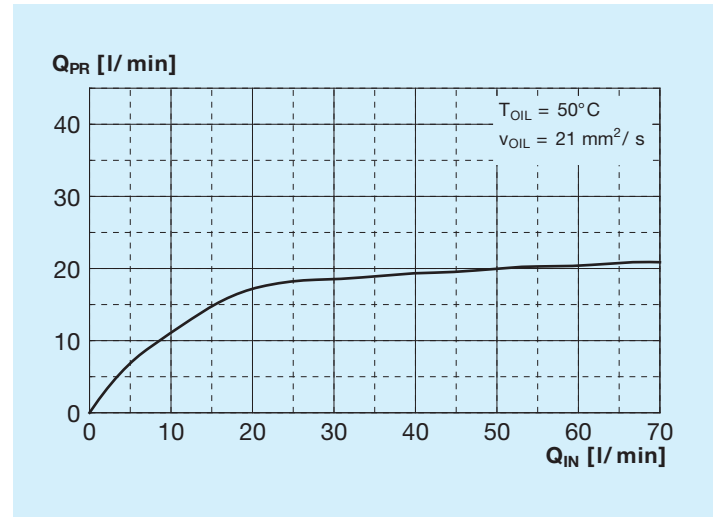
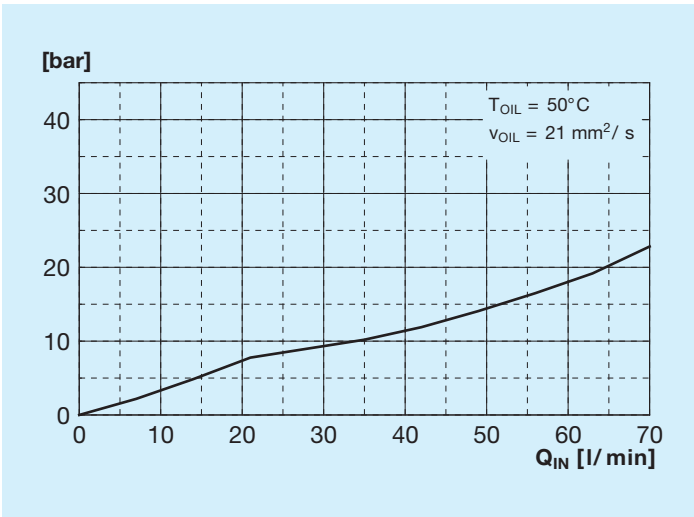

ΔP P - PR cursor 0-40 l/min

Flow rate P - PR cursor 0-40 l/min

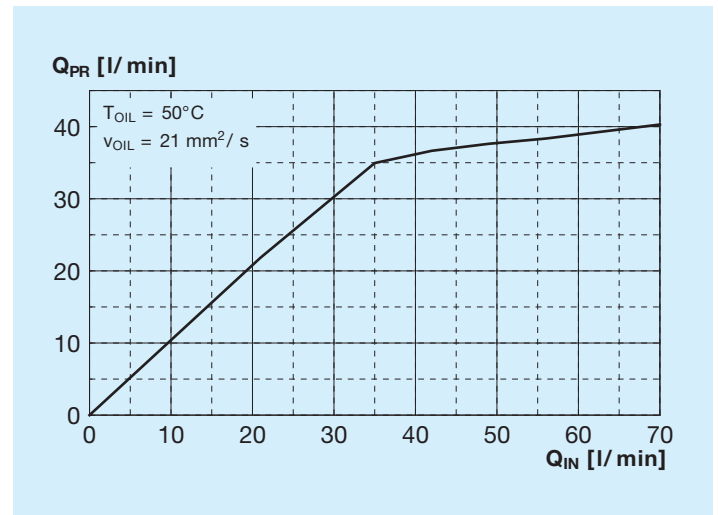
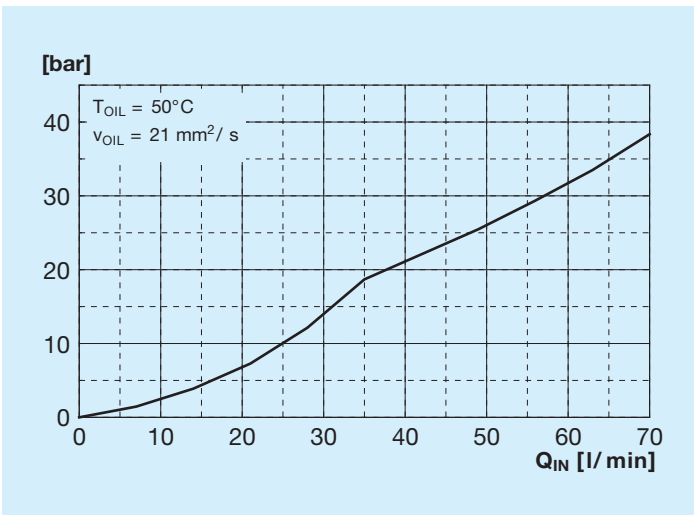

2-way priority cursor N.O.

ΔP P - EX/T

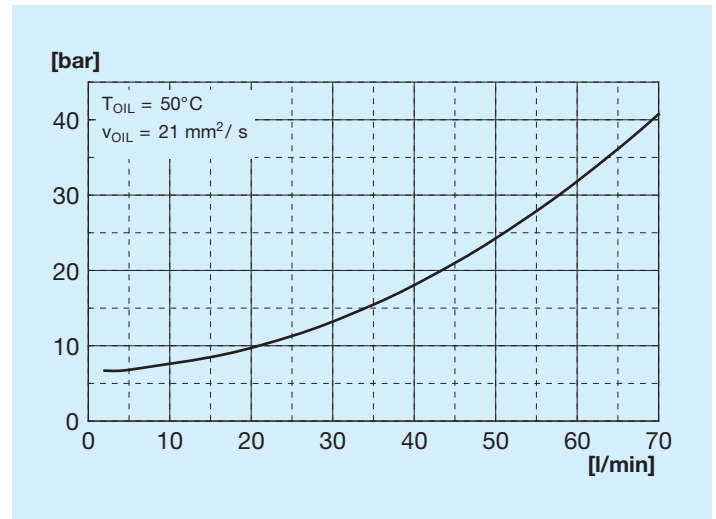
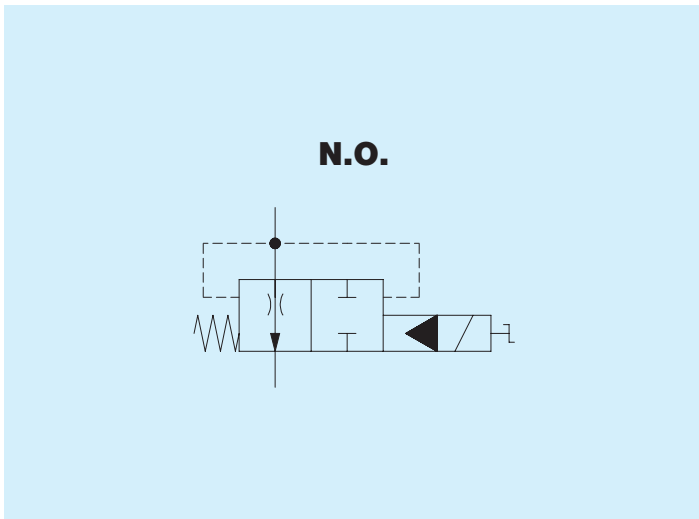

ΔP P - PR cursor 40-0 l/min

Flow rate P - PR Cursor 40-0 l/min

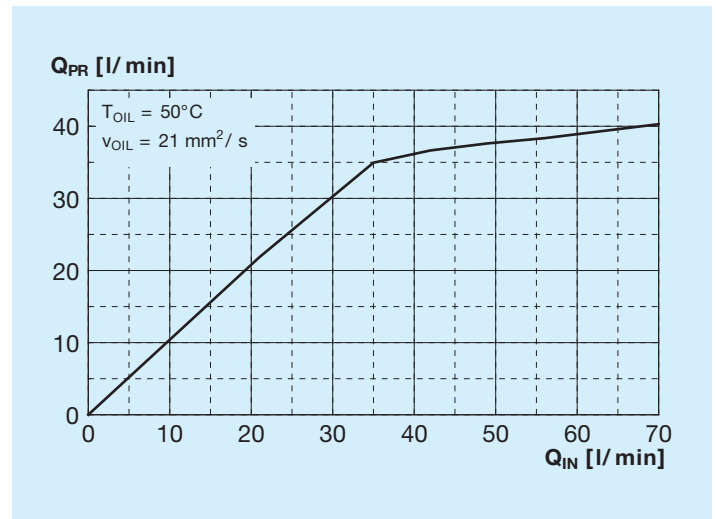
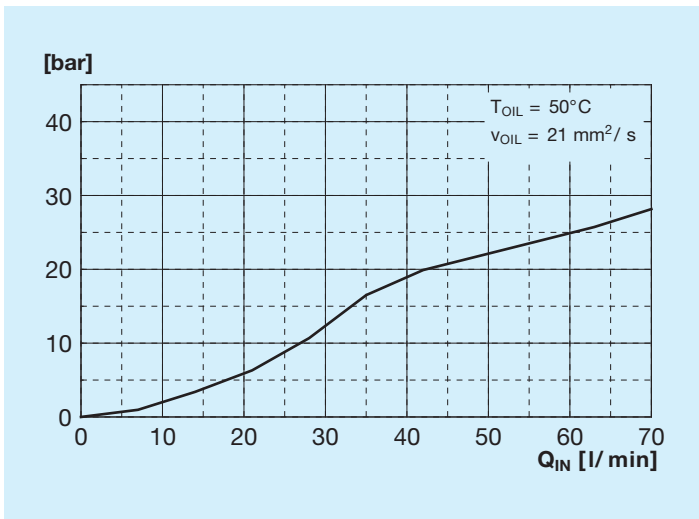

Thread port PR

Model	Type	Torque Nm
A	3/8" GAS ISO 1179	40
C	M18x1.5 ISO 9974	40
W	M18x1.5 ISO 6149	40
E	3/4" 16 SAE ISO 11926	50

A RC Pressure limiter and anticavitation cartridge

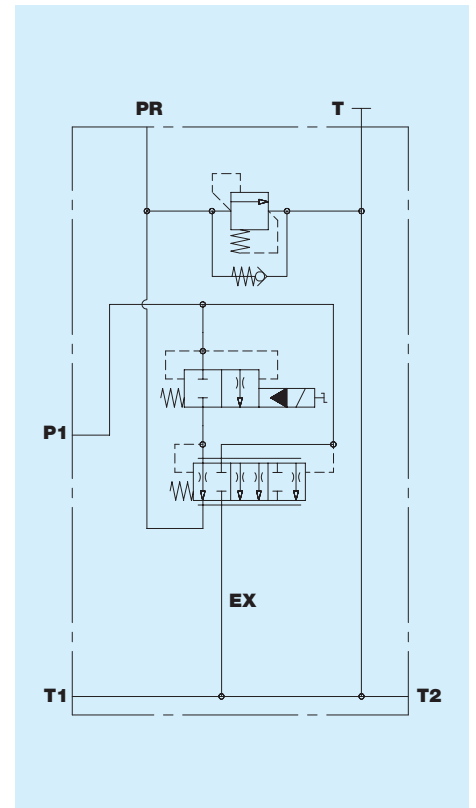
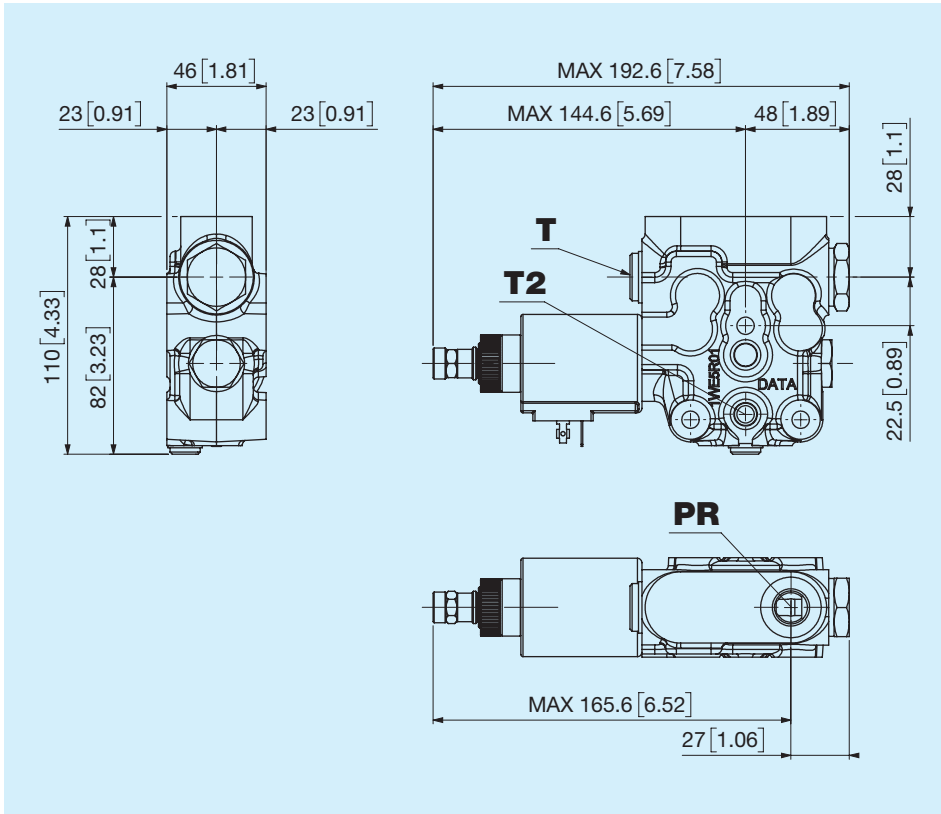

B VL Adjustable pressure limiting valve

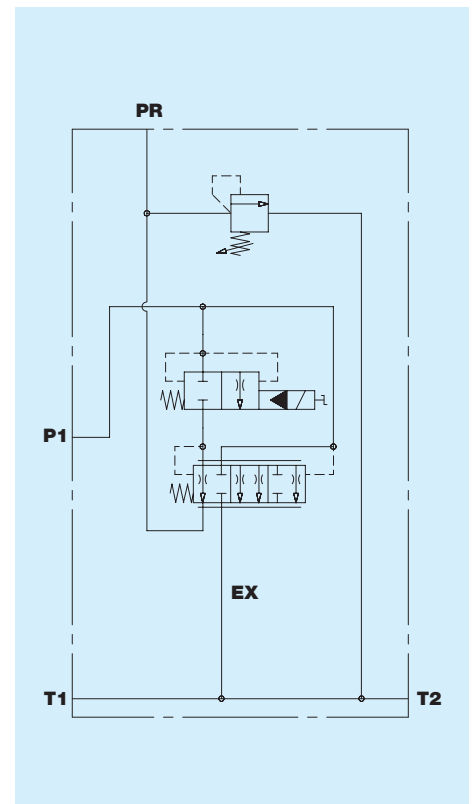
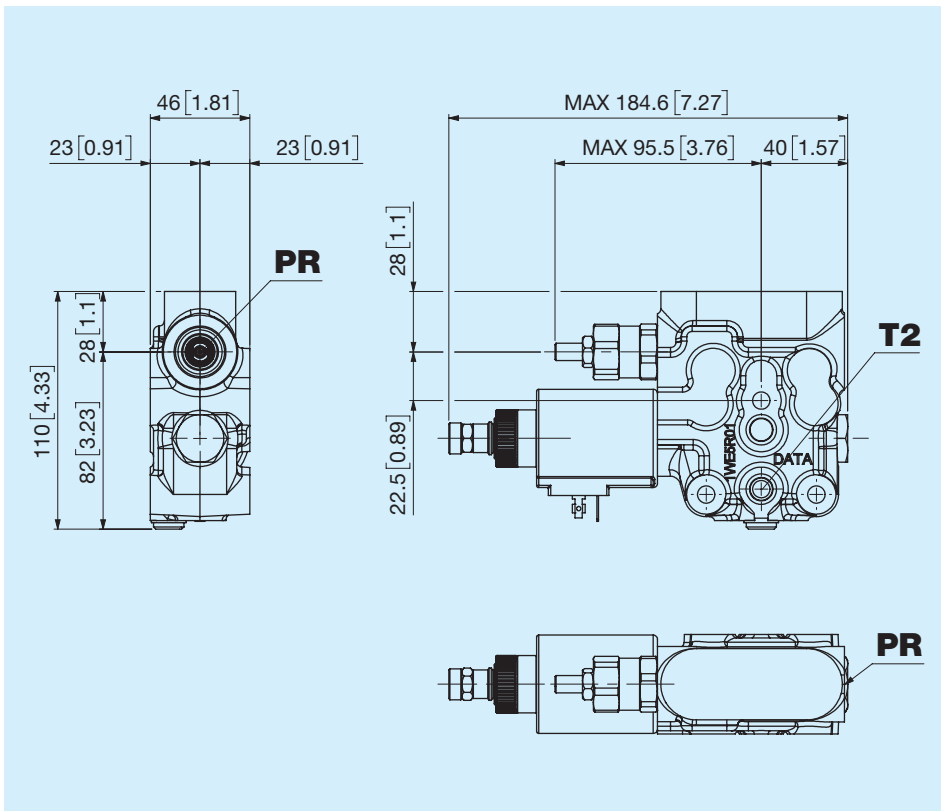



1	Actuator options	
1	L Stroke limiting	
2	Regulated flow rate	
2	A N.C. Normally closed 0 - 40 l/min 0 - 10.56 US	B N.C. Normally closed 0 - 20 l/min 0 - 5.28 US gpm
		C N.O. Normally open 40 - 0 l/min 10.56 - 0 US
3	Thread type	
3	F Female	M Male
4	Thread port PR	
4	A 3/8" GAS ISO 1179	C M18x1.5 ISO 9974
		W M18x1.5 ISO 6149
		E 3/4" - 16 SAE ISO 11926
5	Options line PR	
5	N None	A RC Pressure limiter and anticavitation cartridge
		B VL Adjustable pressure limiting valve
6 7	Calibration pressure VL/RC	
6 7	NN None	08 80 bar
	03 30 bar	09 90 bar
	04 40 bar	10 100 bar
	05 50 bar	11 110 bar
	06 60 bar	12 120 bar
	07 70 bar	13 130 bar
		14 140 bar
		15 150 bar
		16 160 bar
		17 170 bar
		18 180 bar
		19 190 bar
		20 200 bar
		21 210 bar
		22 220 bar
		23 230 bar
		24 240 bar
		25 250 bar
8	Voltage and connector	
8	A 12V DIN 43650	B 24V DIN 43650
9	External treatment	
9	A External treatment	N None