



**POMPE A PISTONI ASSIALI PER CIRCUITO
CHIUSO A CILINDRATA VARIABILE**

***VARIABLE DISPLACEMENT
CLOSED CIRCUIT AXIAL PISTON PUMPS***

**AXIALKOLBENVERSTELLPUMPEN
FÜR DEN GESCHLOSSENEN KREISLAUF**

**M4 PV
34.45.50.58.65**

398SCP0093A00

M4 PV

POMPE A PISTONI ASSIALI A CILINDRATA VARIABILE VARIABLE DISPLACEMENT AXIAL PISTON PUMPS AXIALKOLBENVERSTELLPUMPEN

Le pompe a pistoni assiali serie M4PV sono stati concepite per operare in circuito chiuso per impieghi a media pressione.

I vari sistemi di comando disponibili le rendono facilmente adattabili alle esigenze applicative sia per il settore industriale che per quello del mobile in generale.

Lo sviluppo di gruppi rotanti appositamente concepiti unito ad uno studio accurato delle sezioni di passaggio dell'olio, consentono a queste pompe di raggiungere elevate velocità di rotazione, come quelle consentite dai moderni motori diesel, garantendo una elevata affidabilità per pressioni di funzionamento fino a 250 bar continui (350 bar di picco). Le pompe possono essere composte in versione tandem, utilizzando le opportune predisposizioni disponibili a richiesta.

M4PV series axial piston pumps have been designed to work in a closed circuit. Control systems actually available are making easy to use these pumps in any application for industrial and mobile field. Development of rotating groups, especially designed, united to an accurate study of oil passage sections, allow high speed rotation, like required by modern diesel engines, giving extreme reliability for working continuous pressure until 250 bar and working peak pressure until 350 bar.

It is possible to couple tandem versions, by means of coupling flanges optionally available.

Die Axialkolbenpumpen der Serie M4PV wurden für den Betrieb im geschlossenen Kreislauf konzipiert.

Die lieferbaren unterschiedlichen Steuerungssysteme eignen sich sowohl für stationäre als auch für mobile Anwendungen im Allgemeinen.

Speziell entwickelte Zylinderblöcke mit optimalen Saugverhältnissen erlauben den Einsatz bei hohen Pumpendrehzahlen, wie von modernen Antriebsaggregaten gefordert. Dabei ist ein kontinuierlicher Arbeitsdruck von bis zu 250 Bar (Spitzenwert 350 Bar) gewährleistet.

Die Pumpen können in der Tandemversion geliefert werden, wobei die auf Wunsch erhältlichen Flanschverbindungen angewendet werden.

M4 PV 34•45•50•58•65

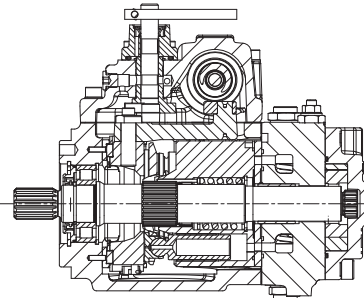
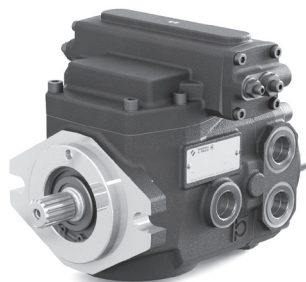

DATI TECNICI TECHNICAL DATA TECHNISCHE MERKMALE

GRUPPO GROUP BAUREIHE	CILINDRATA TEORICA NOMINAL DISPLACEMENT FORDERVOLUMEN (TM)		OSCILLANTE SWASHPLATE SCHWENKWINKEL °	CONTINUA CONTINUOUS DAUER		PRESSIONE PRESSURE DRUCK		PICCO PEAK SPITZEN		VELOCITÀ DI ROTAZIONE SPEED DREHZAHL MAX MIN		MASSA WEIGHT GEWICHT	
	cm ³	in ³		bar	psi	bar	psi	bar	psi	min ⁻¹	min ⁻¹	kg	lbs
M4PV	34	2,08	18	300	4350	380	5075	400	5800	3800	500	25,0	55,0
	46	2,81	19	300	4350	380	5075	400	5800	3800	500	25,0	55,0
	50	3,05	18	300	4350	380	5075	400	5800	3800	500	25,0	55,0
	58	3,54	18	250	3625	320	4640	400	5800	3600	500	26,5	58,3
	65	3,97	18	250	3625	320	4640	400	5800	3600	500	28,9	63,6

POMPA DI ALIMENTAZIONE BOOST PUMP SPEISEPUMPE

TIPO TYPE TYP	CILINDRATA STANDARD POMPA DI ALIMENTAZIONE BOOST PUMP STANDARD DISPLACEMENT FORDERVOLUMEN STANDARD SPEISEPUMPE		PRESSIONE PRESSURE DRUCK	
	cm ³	in ³		bar
M4PV34	14	0,86	22	319
M4PV46	14	0,86	22	319
M4PV50	14	0,86	22	319
M4PV58	14	0,86	22	319
M4PV65	14	0,86	22	319



**DIMENSIONI
SIZE
ABMESSUNGEN**

M4 PV

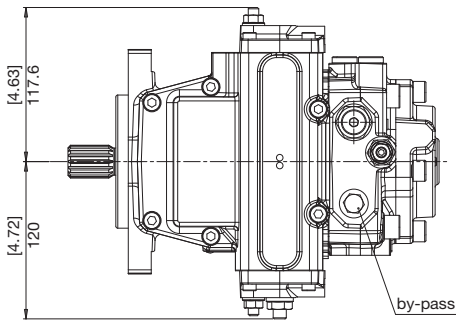
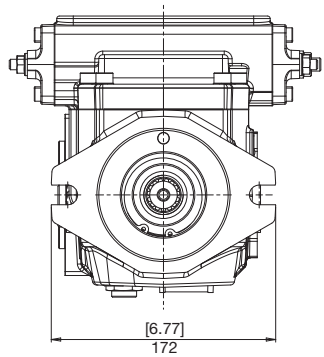
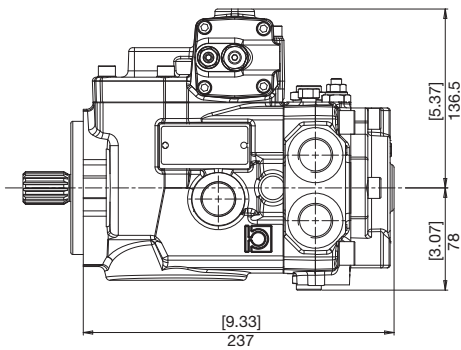

B SAE B
SAE B
SAE B

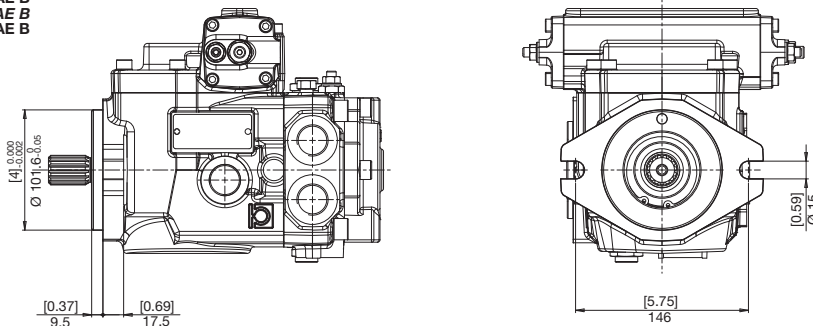

ESTREMITÀ ALBERI
SPLINE SHAFTS
WELLENPROFILE

1 COPPIA MAX
MAX TORQUE
MAX DREHMOMENT 210 N•m

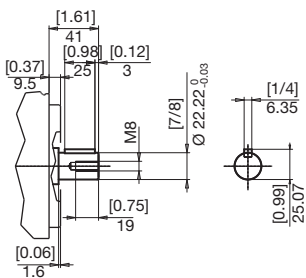

2 COPPIA MAX
MAX TORQUE
MAX DREHMOMENT 285 N•m

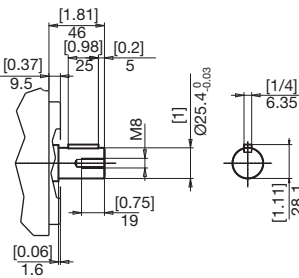

3 COPPIA MAX
MAX TORQUE
MAX DREHMOMENT 460 N•m

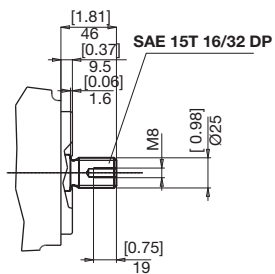

4 COPPIA MAX
MAX TORQUE
MAX DREHMOMENT 300 N•m

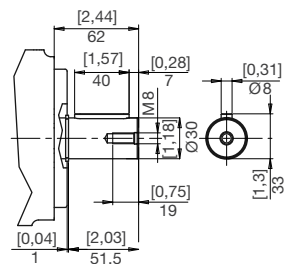

6 COPPIA MAX
MAX TORQUE
MAX DREHMOMENT 310 N•m

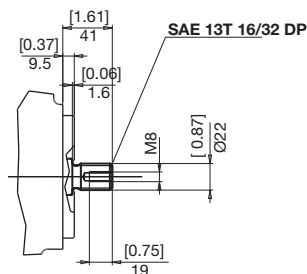



**BOCCHIE
PORTS
ANSCHLÜSSE**

M4 PV

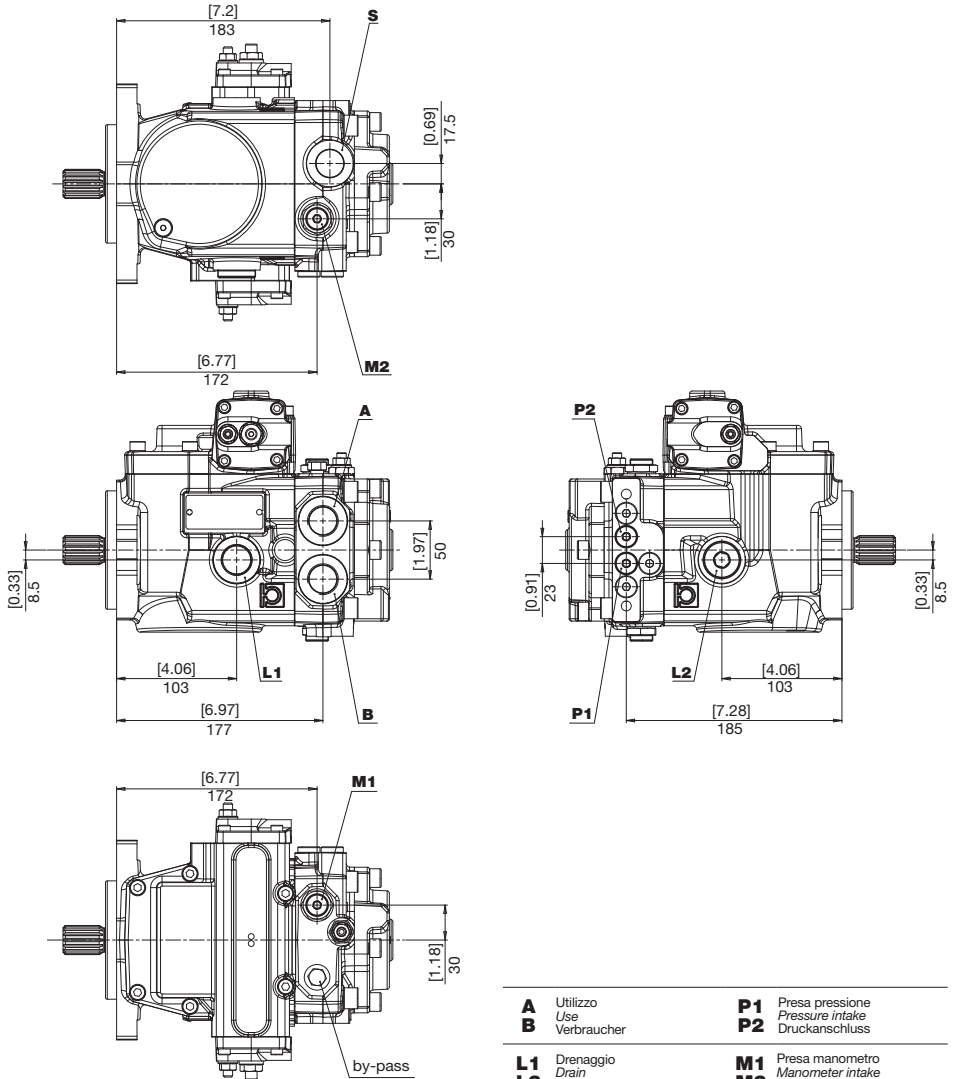

**BOCCHIE
PORTS
ANSCHLÜSSE**

M4 PV

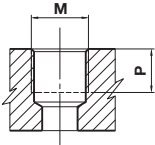

TIPO TYPE TYP		M		P	
		Nm	mm	in	
G2	Port ISO 1179-1 - G 1/4	17	12		0,47
G6	Port ISO 1179-1 - G 1/4	90	15		0,59

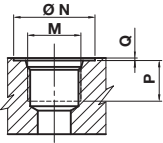

TIPO TYPE TYP	DIMENSIONE SIZE GRÖSSE	N		P		Q		M	Nm
		mm	in	mm	in	mm	in		
U2	1/4"	20	0,79	12	0,47	0,3	0,01	Port ISO 1196-1-7/16-20	17
U6	3/4"	42	1,65	18	0,70	0,3	0,01	Port ISO 1196-1-1 1/16-12	90

**COMBINAZIONI
COMBINATIONS
KOMBINATIONEN**

TIPO TYPE TYP	S ASPIRAZIONE INLET SAUGSEITE	A - B MANDATA OUTLET AUSGANG	L1 - L2 DRENAGGIO DRAIN LECKÖLANSCHLUSS	a - b PILOTAGGIO PILOT STEUERDRUCK	P1 - P2 PRESE PRESSIONE PRESSURE INTAKE DRUCKANSCHLUSS	M1 - M2 PRESE MANOMETRO MANOMETER INTAKE MANOMETER- ANSCHLUSS
R	G6	G6	G6	G2	G2	G2
U	U6	U6	U6	U2	G2	U2

**COMANDI
CONTROLS
STEUERUNGEN**

M4 PV

D AUTOMOTIVE
AUTOMOTIVE
AUTOMOTIVE
12 V

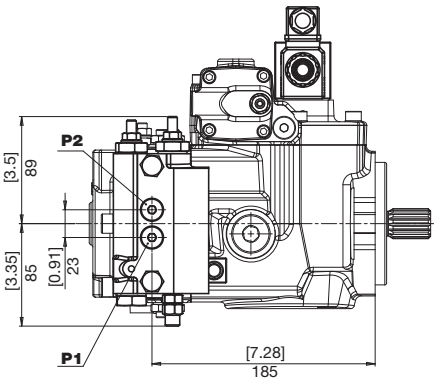
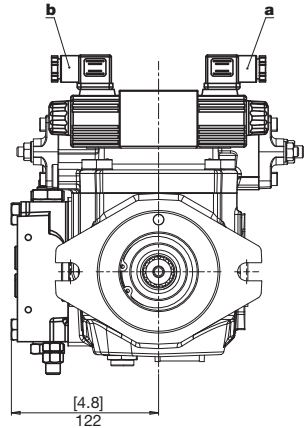
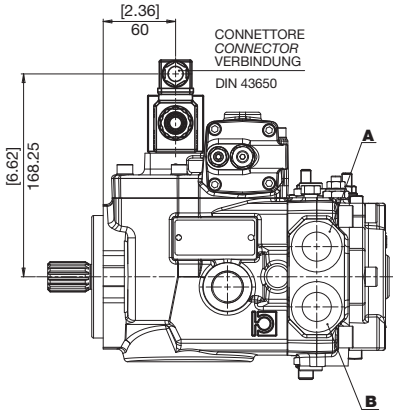

ROTAZIONE DIRECTION DREHRICHTUNG	SOLENOIDE IN TENSIONE EXCITED SOLENOID SOLENOID UNTER SPANNUNG	MANDATA OUTPUT AUSGANG
DESTRA RIGHT RECHTS	a	B
SINISTRA LEFT LINKS	a	A
	b	B

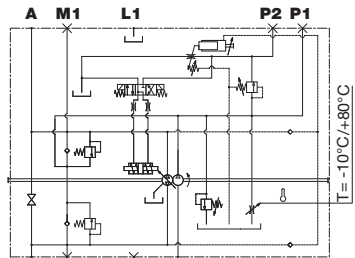

E F

**ELETTRICO ON/OFF CENTRO CHIUSO
ELECTRICAL ON/OFF, CLOSED CENTER
ELEKTRISCH ON/OFF, GESCHLOSSENES VENTIL**

12 V 24 V

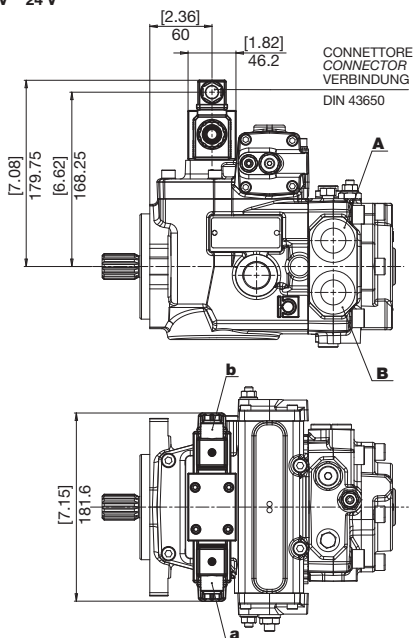

ROTAZIONE DIRECTION DREHRICHTUNG	SOLENOIDE IN TENSIONE EXCITED SOLENOID SOLENOID UNTER SPANNUNG	MANDATA OUTPUT AUSGANG
DESTRA RIGHT RECHTS	a	B
SINISTRA LEFT LINKS	b	A
	a	A
	b	B

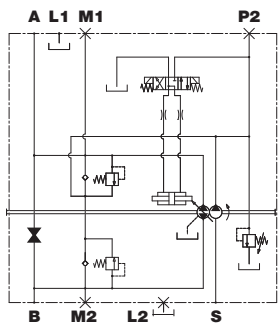

N Q

**ELETTRICO ON/OFF CENTRO APERTO
ELECTRICAL ON/OFF, OPEN CENTER
ELEKTRISCH ON/OFF, VENTIL GEÖFFNET**

12 V 24 V

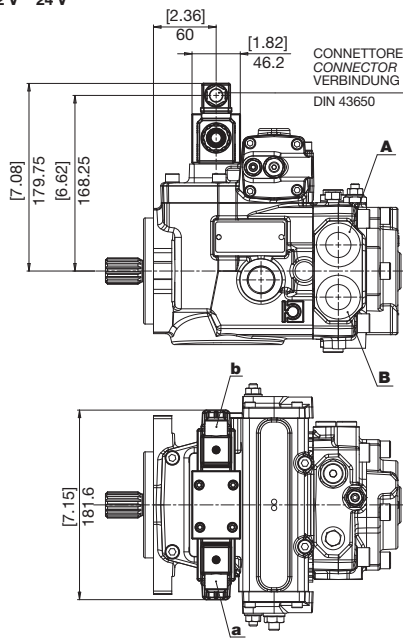

ROTAZIONE DIRECTION DREHRICHTUNG	SOLENOIDE IN TENSIONE EXCITED SOLENOID SOLENOID UNTER SPANNUNG	MANDATA OUTPUT AUSGANG
DESTRA RIGHT RECHTS	a	B
SINISTRA LEFT LINKS	b	A
	a	A
	b	B

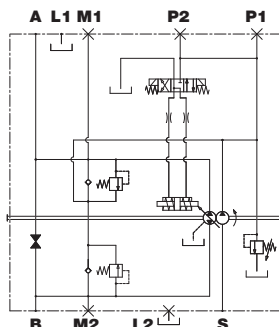

**COMANDI
CONTROLS
STEUERUNGEN**

M4 PV

G IDRAULICO RETROAZIONATO
HYDRAULIC, FEEDBACK
HYDRAULISCH, RÜCKGEFÜHRT

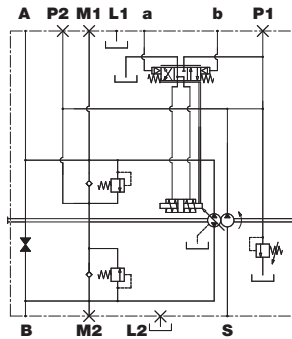
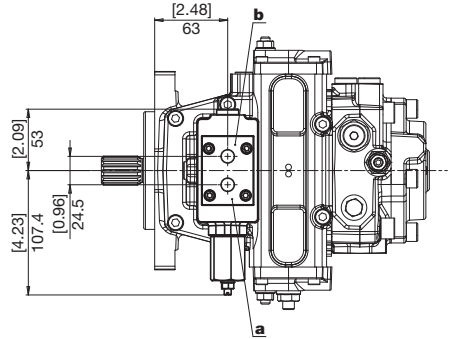
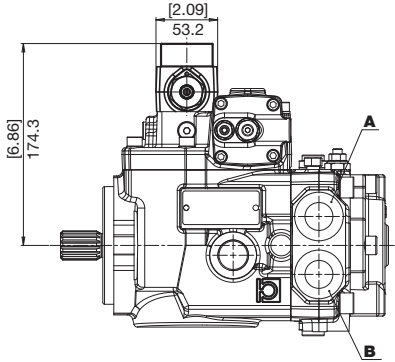

ROTAZIONE DIRECTION DREHRICHTUNG	PILOTAGGIO PILOT PRESSURE STEUERDRUCK	MANDATA OUTPUT AUSGANG
DESTRA RIGHT RECHTS	a	B
SINISTRA LEFT LINKS	a	A
	b	B

a Pressione di pilotaggio
Pilot Pressure

b Steuerdruck

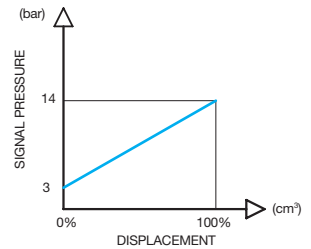

I SERVOCOMANDO A LEVA
LEVER-OPERATED SERVO-CONTROL
HYDRAULISCHE HEBEL-SERVOSTEUERUNG

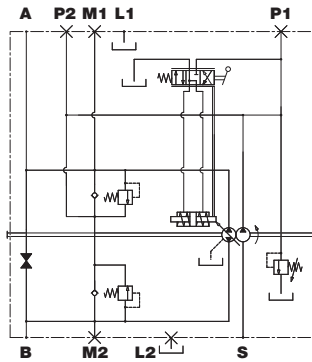
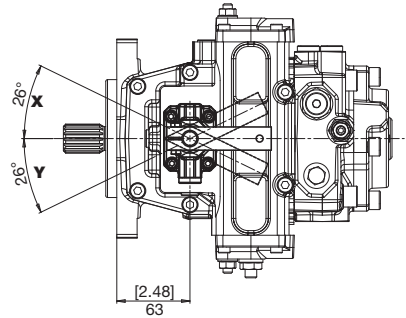
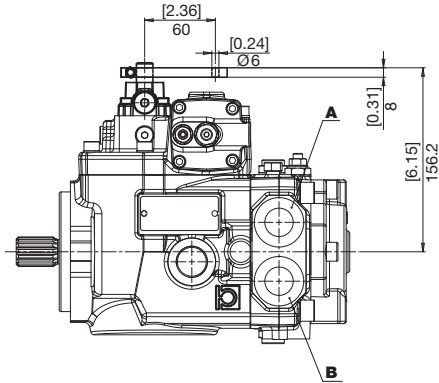

ROTAZIONE DIREZIONE DREHRICHTUNG	LEVA COMANDO CONTROL LEVER STEUERHEBEL	MANDATA OUTPUT AUSGANG
DESTRA RIGHT	Y	A
RECHTS	X	B
SINISTRA LEFT	Y	B
LINKS	X	A

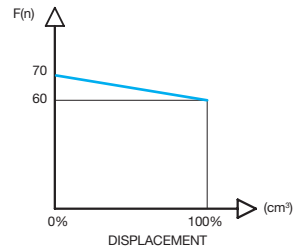

**COMANDI
CONTROLS
STEUERUNGEN**

M4 PV

K IDRAULICO A DISTANZA
REMOTE HYDRAULIC
HYDRAULISCHE FERNSTEUERUNG

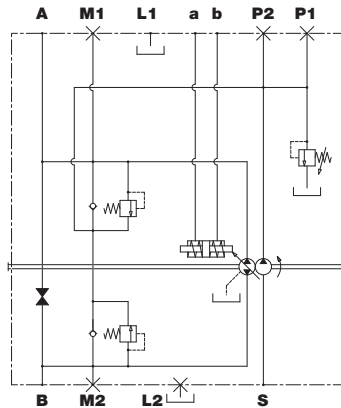
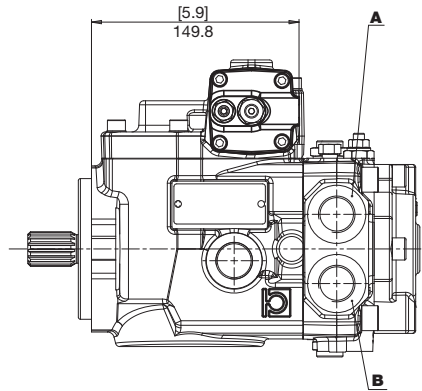
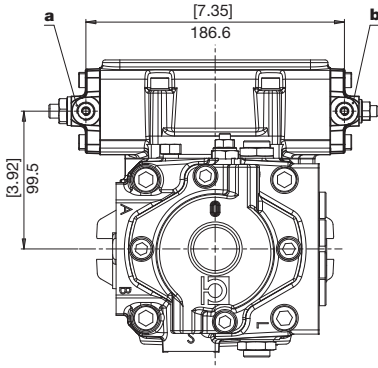

ROTAZIONE DIRECTION DREHRICHTUNG	PILOTAGGIO PILOT PRESSURE STEUERDRUCK	MANDATA OUTPUT AUSGANG
DESTRA RIGHT RECHTS	a	A
	b	B
SINISTRA LEFT LINKS	a	B
	b	A

a Pressione di pilotaggio
Pilot Pressure
b Steuerdruck

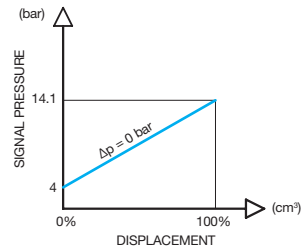



ELETTRICO PROPORZIONALE RETROAZIONATO
ELECTRICAL PROPORTIONAL FEEDBACK CONTROL
ELEKTRISCH PROPORZIONALSTEUERUNG RÜCHGEFÜHRT

12 V 24 V

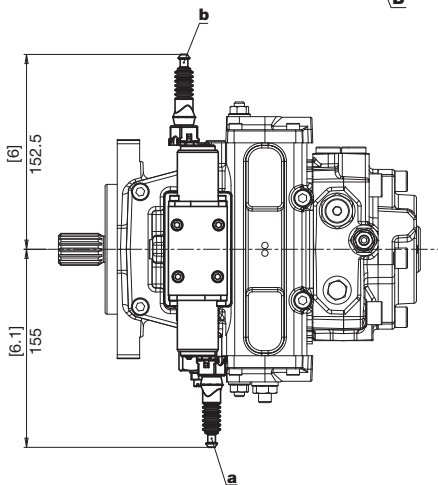
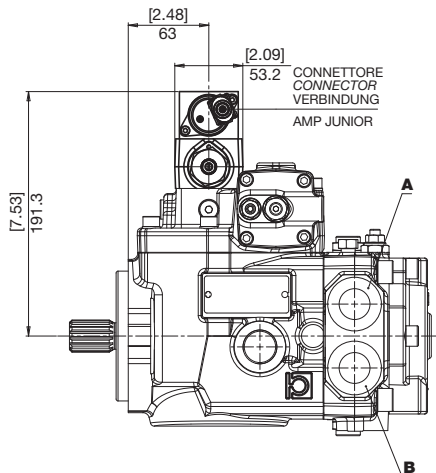

ROTAZIONE DIRECTION DREHRICHTUNG	SOLENOIDE IN TENSIONE EXCITED SOLENOID SOLENOID UNTER SPANNUNG	MANDATA OUTPUT AUSGANG
DESTRA RIGHT RECHTS	a	B
SINISTRA LEFT LINKS	a	A
	b	B



Tensione nominale Rated voltage Nennspannung	12	24	V
Corrente min (I1) Min. current Mindeststrom	300	180	mA
Corrente max (I2) Max. current Maximaler Strom	1500	850	mA
Frequenza PWM PWM Frequency Frequenz PWM	100	100	Hz

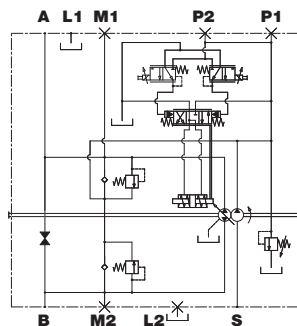
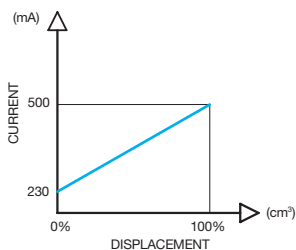
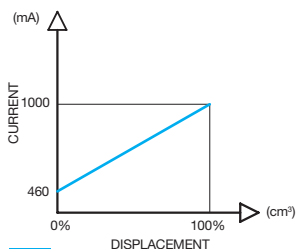



**COMANDI
CONTROLS
STEUERUNGEN**

M4 PV

S W
12 V 24 V

**ELETTRICO PROPORZIONALE DIRETTO
ELECTRICAL PROPORTIONAL CONTROL
ELEKTRISCH PROPORZIONALSTEUERUNG**

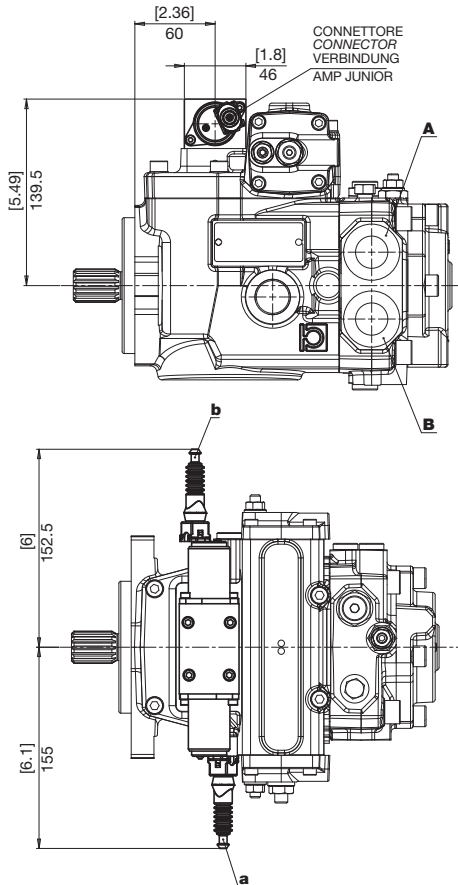

ROTAZIONE DIRECTION DREHRICHTUNG	SOLENOIDE IN TENSIONE EXCITED SOLENOID SOLENOID UNTER SPANNUNG	MANDATA OUTPUT AUSGANG
DESTRA RIGHT RECHTS	a	A
SINISTRA LEFT LINKS	a	B
	b	A

S W

Tensione nominale Rated voltage Nennspannung	12	24	V
Corrente min (I1) Min. current Mindeststrom	300	180	mA
Corrente max (I2) Max. current Maximaler Strom	1500	850	mA
Frequenza PWM PWM Frequency Frequenz PWM	100	100	Hz

S

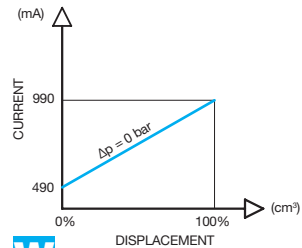

W

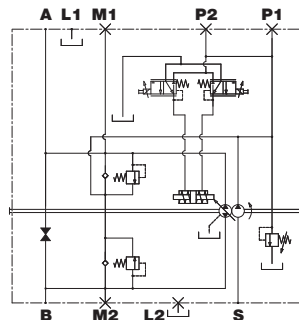
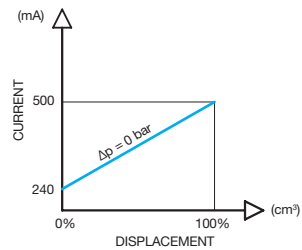

M MANUALE
MANUAL
MANUELLERS STEUERUNG

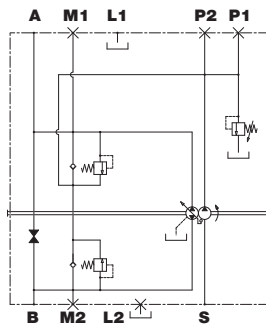
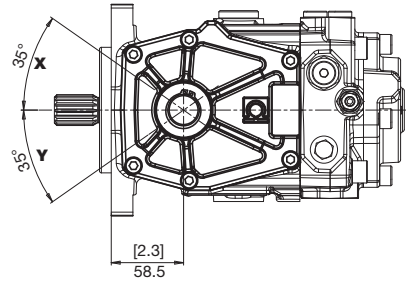
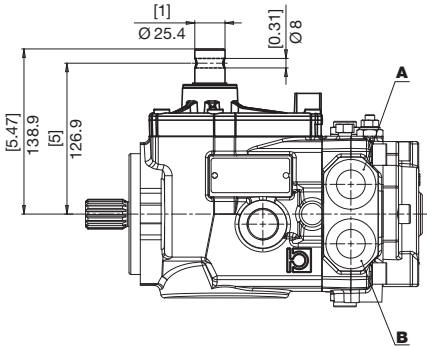

ROTAZIONE DIRECTION DREHRICHTUNG	LEVA COMANDO CONTROL LEVER STEUERHEBEL	MANDATA OUTPUT AUSGANG
DESTRA RIGHT	Y	A
RECHTS	X	B
SINISTRA LEFT	Y	B
LINKS	X	A



**PREDISPOSIZIONI
VERSION
BAUART**

M4 PV

2 SAE A CON POMPA SOVRALIMENTAZIONE
SAE A WITH BOOST PUMP
SAE A MIT SPEISEPUMPE

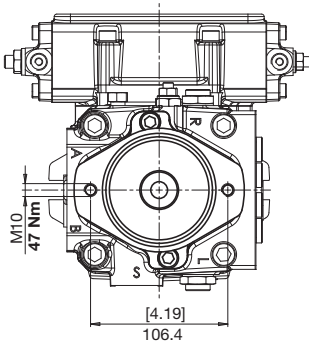

5 SAE A SENZA POMPA SOVRALIMENTAZIONE
SAE A WITHOUT BOOST PUMP
SAE A OHNE SPEISEPUMPE

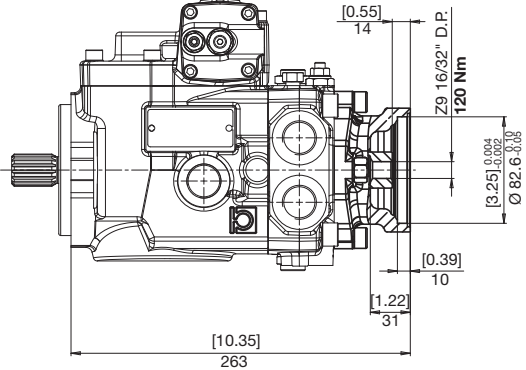

3 SAE B CON POMPA SOVRALIMENTAZIONE
SAE B WITH BOOST PUMP
SAE B MIT SPEISEPUMPE

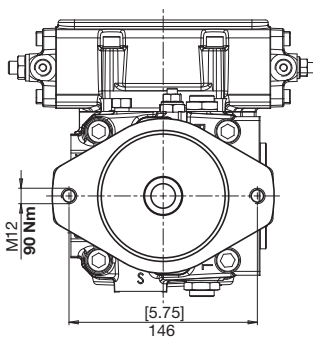

6 SAE B SENZA POMPA SOVRALIMENTAZIONE
SAE B WITHOUT BOOST PUMP
SAE B OHNE SPEISEPUMPE

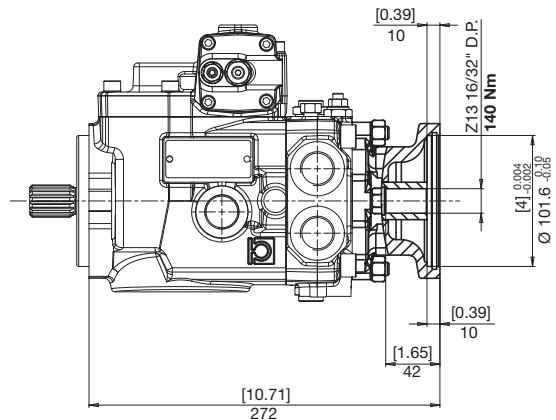

E SICUREZZA OPERATORE ASSENTE
NO OPERATOR SAFETY
SICHERUNG KEIN ARBEITER
12 V

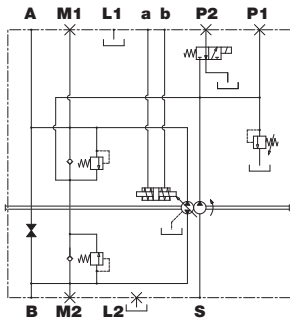
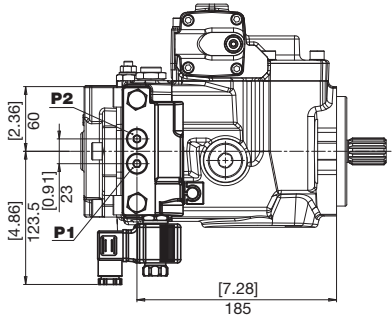
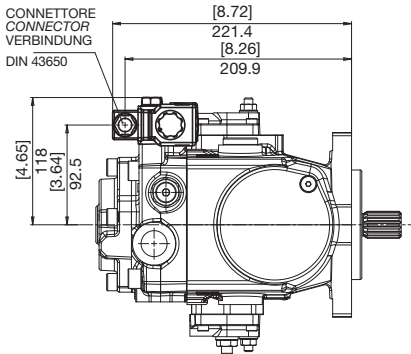

H INCHING IDRAULICO (SOLO COMANDO D)
HYDRAULIC INCHING ("D" CONTROL)
HYDRAULISCHE INCH-VENTIL (NUR STEUERUNG D)

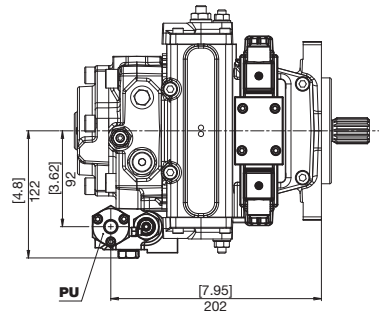
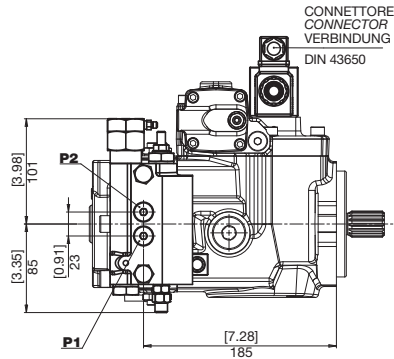

PU Pilotaggio sblocco freno (1/4" GAS)
Brake opening pressure (1/4" GAS)
Bremse Öffnung Druck (1/4" GAS)

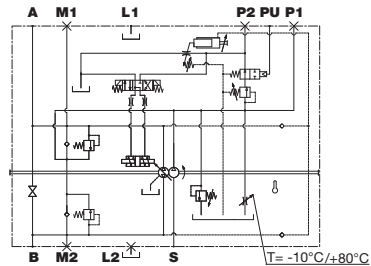

**ACCESSORI
ACCESSORIES
ZUBEHÖR**

M4 PV

J

**TAGLIO DI PRESSIONE
CUT-OFF
DRUCKABSCHNEIDUNG**

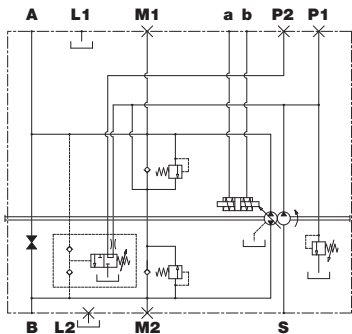
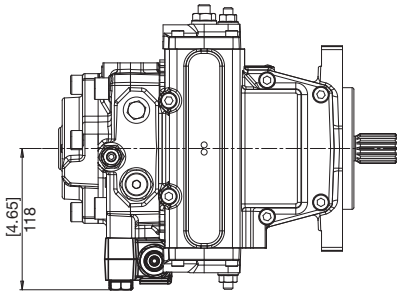
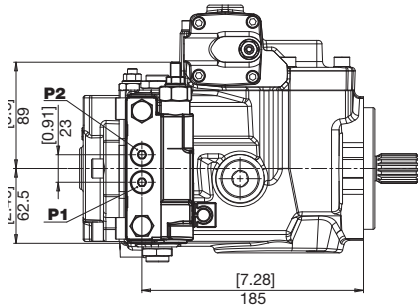

M

**INCHING MECCANICO (SOLO COMANDO D)
MECHANIC INCHING CONTROL ("D" CONTROL)
MECHANISCHES INCH-VENTIL (NUR STEUERUNG D)**

CONNETTORE
CONNECTOR
VERBINDUNG
DIN 43650

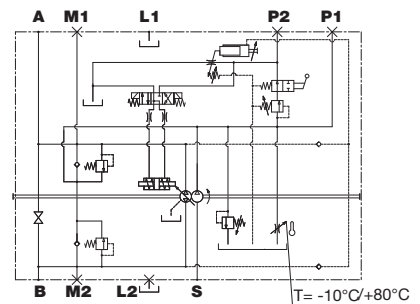
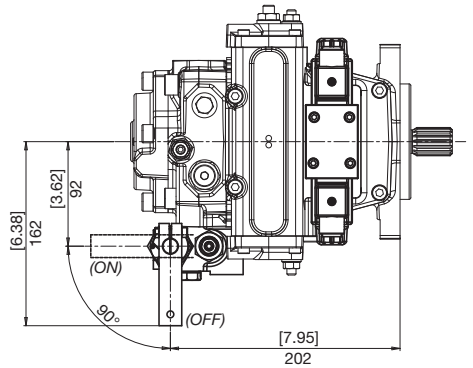
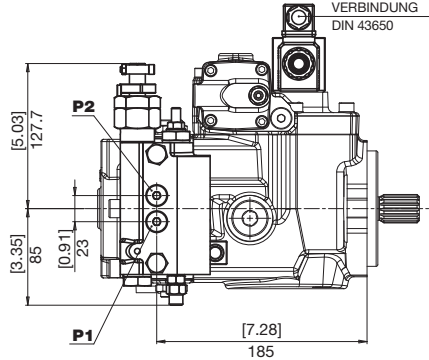

V VALVOLA DI FLUSSAGGIO (5-7 l/min)
FLUSHING AND BOOST VALVE (5-7 l/min)
SPUL-UND SPEISEDRUKVENTIL (5-7 l/min)

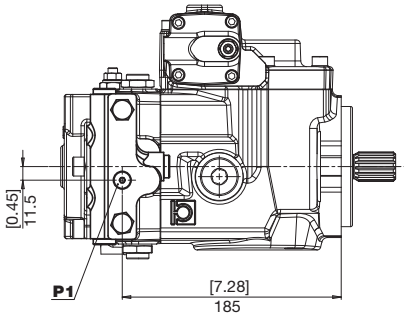

P1 Presa pressione (1/8" GAS)
Pressure intake (1/8" GAS)
Druckanschluss (1/8" GAS)

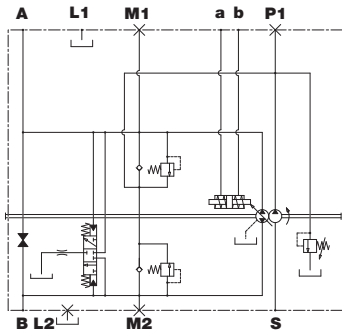

W LIMITATORE DI POTENZA
POWER LIMITER
LEISTUNGSBEGRENZER

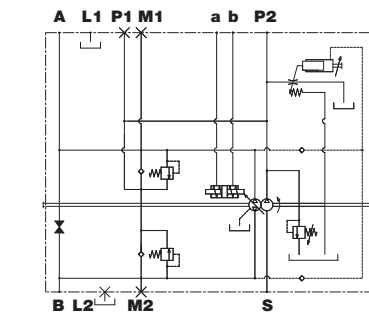
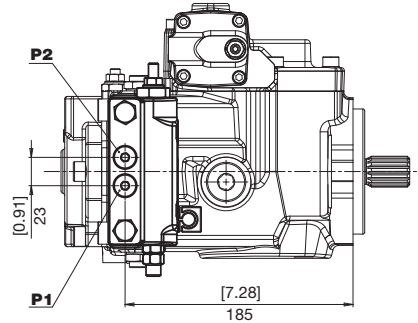



ACCESSORI
ACCESSORIES
ZUBEHÖR

M4 PV

X **FILTRO CON INDICATORE DI INTASAMENTO ELETTRICO**
FILTER WITH ELECTRIC CLOGGING INDICATOR
FILTER MIT ELEKTRISCHEM VERSTOPFUNGSANZEIGER

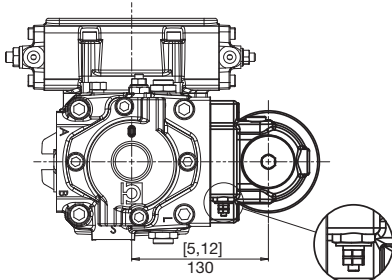

INDICATORE DIFFERENZIALE ELETTRICO 30VDC - 0,2 A max
ELECTRIC DIFFERENTIAL INDICATOR 30VDC - 0,2 A max
ELEKTRISCHER DIFFERENZDRUCKANZEIGER 30VDC - 0,2 A max

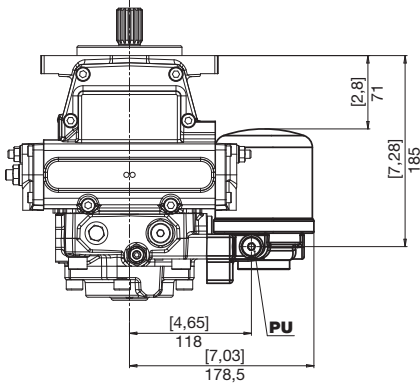

PU Presa olio filtrato (1/4" GAS)
Filtered oil intake (1/4" GAS)
Anschluss filtriertes Öl (1/4" GAS)

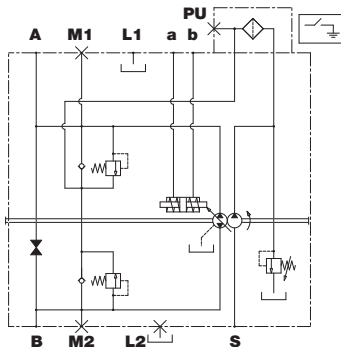

Y **FILTRO SENZA INDICATORE DI INTASAMENTO ELETTRICO**
FILTER WITHOUT ELECTRIC CLOGGING INDICATOR
FILTER OHNE ELEKTRISCHEN VERSTOPFUNGSANZEIGER

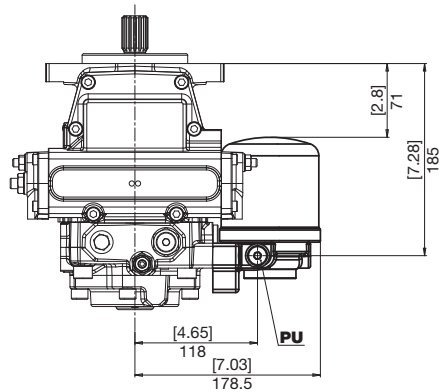
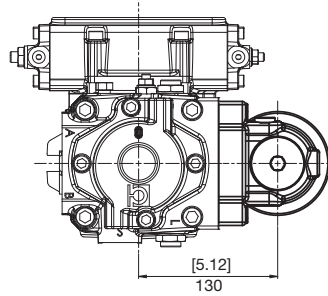

PU Presa olio filtrato (1/4" GAS)
Filtered oil intake (1/4" GAS)
Anschluss filtriertes Öl (1/4" GAS)

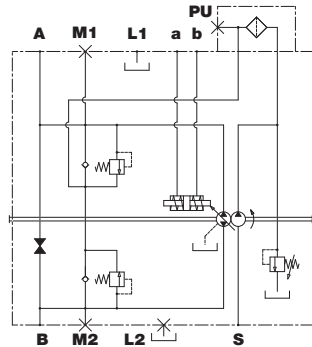

Questa pagina è intenzionalmente bianca
This page is intentionally blank
Diese Seite ist bewusst frei gelassen



ISTRUZIONI PER L'ORDINAZIONE
ORDERING INSTRUCTIONS
BESTELLANLEITUNG

M4 PV

M4PV

58

58

I

1

E

A

R

6

B

Y

...

ESECUIZIONI SPECIALI
SPECIAL VERSIONS
SONDERBAUARTEN

SERIE
SERIES
SERIE

CILINDRATE NOMINALI
RATED DISPLACEMENT
NENNFORDEVOLUMEN
34 - 46 - 50 - 58 - 65

CILINDRATA
DISPLACEMENT
FORDEVOLUMEN
34 - 46 - 50 - 58 - 65

COMANDO CONTROL STEUERUNG

D = Automotiv
E = Elettrico (12 V)
F = Elettrico (24 V)
G = Servocomando idraulico retroazionato
I = Servocomando a leva
K = Servocomando idraulico a distanza
M = Manuale
N = Elettrico on/off (12 V)
O = Elettrico on/off (24 V)
Q = Elettronico proporzionale retroazionato (12V)
V = Elettronico proporzionale retroazionato (24V)
S = Elettronico proporzionale (12V)
W = Elettronico proporzionale (24V)

D = *Automotive control*
E = *Electric (12 V)*
F = *Electric (24 V)*
G = *Hydraulic remote feedback*
I = *Lever-operated servo-control*
K = *Remote servo-control*
M = *Manual control*
N = *Electric on/off (12 V)*
O = *Electric on/off (24 V)*
Q = *Electronic proportional feedback (12V)*
V = *Electronic proportional feedback (24V)*
S = *Electronic proportional (12V)*
W = *Electronic proportional (24V)*

D = Automotiv
E = Elektrische (12V)
F = Elektrische (24V)
G = Hydraulik Fernsteuerung Rückgeführt
I = Hydraulische Hebel-Servosteuerung
K = Fern-Servosteuerung
M = Manuellers steuerung
N = Elektrische on/off (12V)
O = Elektrische on/off (24V)
Q = Elektronische Proportional Rückgeführt (12V)
V = Elektronische Proportional Rückgeführt (24V)
S = Elektronische Proportional (12V)
W = Elektronische Proportional (12V)

PREDISPOSIZIONI VERSION BAUART

1 = nessuna con pompa di alimentazione
2 = SAE A con pompa di alimentazione
3 = SAE B 2 fori con pompa di alimentazione
4 = nessuna senza pompa di alimentazione
5 = SAE A senza pompa di alimentazione
6 = SAE B 2 fori senza pompa di alimentazione
7 = flangia bassa SAE B 2 fori senza pompa di alimentazione (solo per pompe tandem)

1 = no special fittings with boost pump
2 = SAE A mounting with boost pump
3 = SAE B - 2 holes mounting with boost pump
4 = no special fittings, no boost pump
5 = SAE A mounting without boost pump
6 = SAE B - 2 holes mounting without boost pump
7 = low flange SAE B 2 holes no boost pump (for tandem pump only)

1 = ohne Anschlußflansch mit Speisepumpe
2 = SAE A Anschlußflansch mit Speisepumpe
3 = SAE B Anschlußflansch, mit 2 Bohrungen, mit Speisepumpe
4 = ohne Anschlußflansch, ohne Speisepumpe
5 = SAE A Anschlußflansch ohne Speisepumpe
6 = SAE B Anschlußflansch, mit 2 Bohrungen, ohne Speisepumpe
7 = Niedrigflansch SAE B, 2 Bohrungen, ohne Speisepumpe (nur für Tandempumpen)

TARATURA VALVOLE
VALVE SETTING
VENTILE

B - 150 bar
D - 180 bar
E - 210 bar
G - 250 bar
I - 280 bar
L - 300 bar
O - 350 bar
P - 400 bar

gdt. weglassen

Omit. if not required

Omettere se non richiesto

ACCESSORI ACCESSORIES ZUBEHÖR

O = nessuna opzione
E = sicurezza "operatore assente"
H = inching idraulico (comandi "D")
J = cut-off
M = inching meccanico (comandi "D")
R = filettatura GAS
U = filettatura UNF
V = valvola di flussaggio
W = limitatore di potenza
Y = filtro su linea sovralimentazione
X = filtro su linea sovralimentazione con indicatore intasamento elettrico

O = no accessories
E = "no operator" safety
H = hydraulic inching ("D" control)
J = cut-off
M = mechanic inching ("D" control)
R = GAS threads
U = UNF threads
V = flushing and boost valve
W = power limiter
Y = filter on charge line
X = filter on charge line with electric clogging indicator

O = kein Zubehör
E = Sicherung "kein arbeiter"
H = Hydraulische Inch-Ventil ("D" steuerung)
J = Druckschneidung
M = Mechanische Inch-Ventil ("D" steuerung)
R = GAS Gewinde
U = UNF Gewinde
V = Spül- und speisedruckventil
W = Leistungsbegrenzer
Y = Filter auf Speisedruckleitung
X = Filter auf Speisedruckleitung mit elektrischem Anzeiger

B = Valvola by-pass
B = By-pass valve
B = Bypass-Ventil

ESTREMITÀ D'ALBERO SHAFT PROFIL
WELLENENDE

1 = cilindrico Ø 22.22 (7/8")
2 = cilindrico Ø 25.4 (1")
3 = scanalato maschio 16/32" d.p. Z 15 (Std)
4 = scanalato Ø 30
5 = scanalato femmina 16/32" d.p. Z 13
6 = scanalato maschio 16/32" d.p. Z 13

1 = Round shaft Δ 22.22 (7/8")
2 = Round shaft Δ 25.4 (1")
3 = Male splined shaft Z15 16/32" d.p. (Std)
4 = Round shaft Ø 30
5 = Female splined shaft Z 13 16/32" d.p.
6 = Male splined shaft Z 13 16/32" d.p.

1 = Zylinderisch Ø 22.22 (7/8")
2 = Zylinderisch Ø 25.4 (1")
3 = Profiliwelle Z 15-16/32" d.p. (Std)
4 = Zylinderisch Ø 30
5 = Hohlwelle Z 13-16/32" d.p.
6 = Profiliwelle Z 13-16/32" d.p.

SENSO DI ROTAZIONE DIRECTION OF ROTATION
DREHRICHTUNG

R = Destro
Right
Rechts

L = Sinistro
Left
Links

TIPO DI OSCILLANTE
SWASHPLATE TYPE
SCHWENKSCHNEIBENLAGERUNG

A = oscillante su rullini
B = oscillante su bronzine
A = mounted on needle bearing
B = mounted on bronze bearings
A = Rollenlager
B = Bronze-Gleitlager

**POMPE MULTIPLE
MULTIPLE PUMPS
MEHRFACHPUMPEN**

**POMPA DOPPIA CON 2 POMPE DI SOVRALIMENTAZIONE
DOUBLE PUMP WITH 2 BOOST PUMPS
TANDEMPUMPE MIT 2 SPEISEPUMPEN**

Il codice di ordinazione di una pompa multipla si ottiene sommando, come mostrato in esempio, i codici delle singole pompe (stadi) ricavati seguendo le regole di ordinazione delle pompe singole.

You build the ordering code of a multiple pump by summing the order code of the individual pumps, see our example.

Der Bestellschlüssel einer Mehrfachpumpe ergibt sich durch Summieren der Einzel-Bestellschlüssel, siehe Beispiel

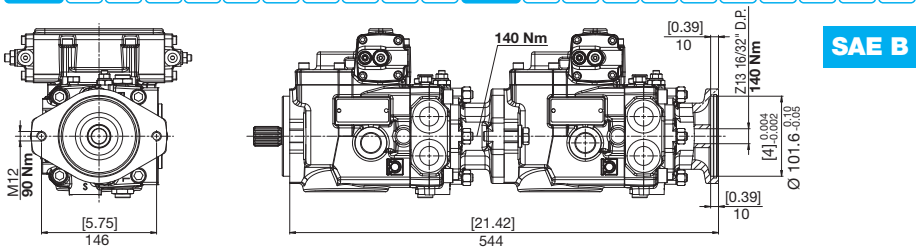
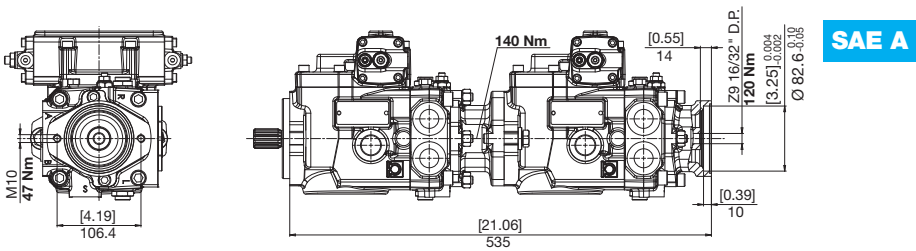
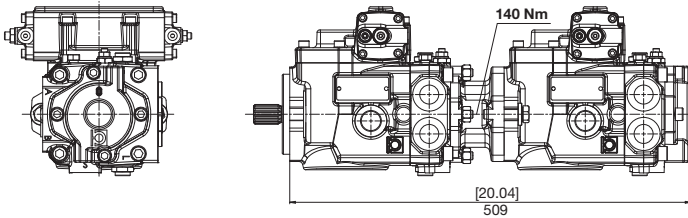

POMPA DOPPIA CON 1 POMPA DI SOVRALIMENTAZIONE
DOUBLE PUMP WITH 1 BOOST PUMP
TANDEMPUMPE MIT 1 SPEISEPUMPE

Il codice di ordinazione di una pompa multipla si ottiene sommando, come mostrato in esempio, i codici delle singole pompe (stadi) ricavati seguendo le regole di ordinazione delle pompe singole.

You build the ordering code of a multiple pump by summing the order code of the individual pumps, see our example.

Der Bestellschlüssel einer Mehrfachpumpe ergibt sich durch Summieren der Einzel-Bestellschlüssel, siehe Beispiel

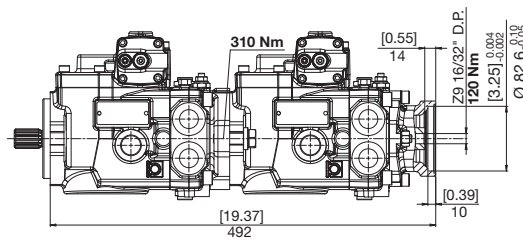
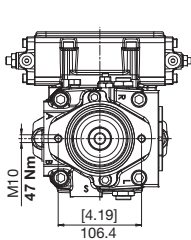
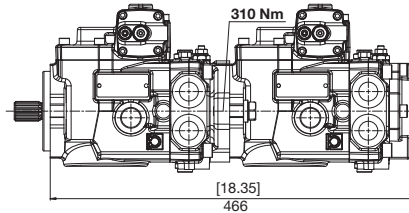
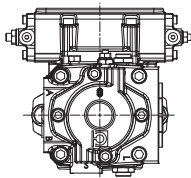

SAE A

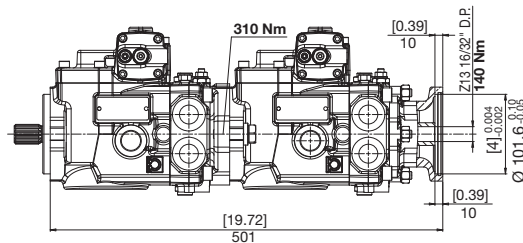
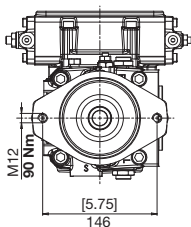

SAE B