

Variable-displacement pumps M4PV21-28-37

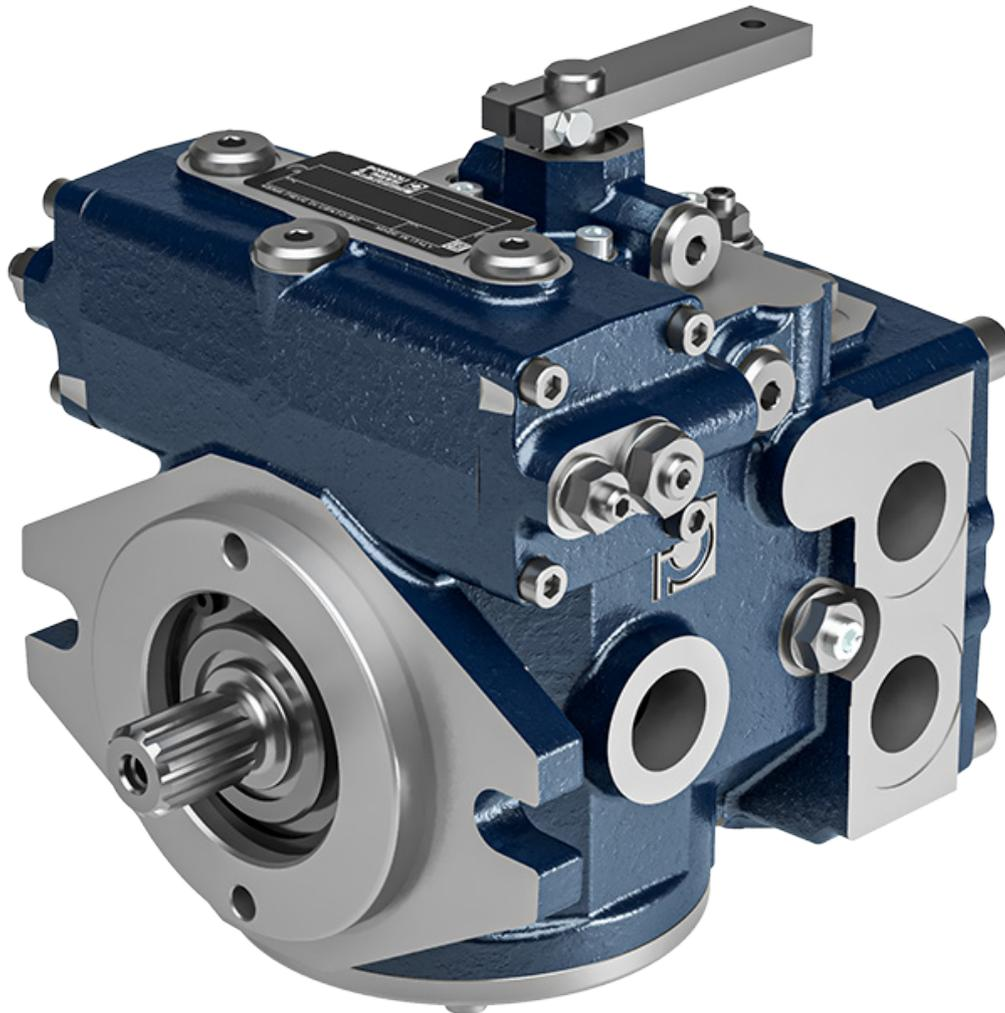

Before using the axial piston pumps and motors, carefully read the GENERAL INSTRUCTIONS FOR USE OF CLOSED CIRCUIT AXIAL PISTON PUMPS AND MOTORS.

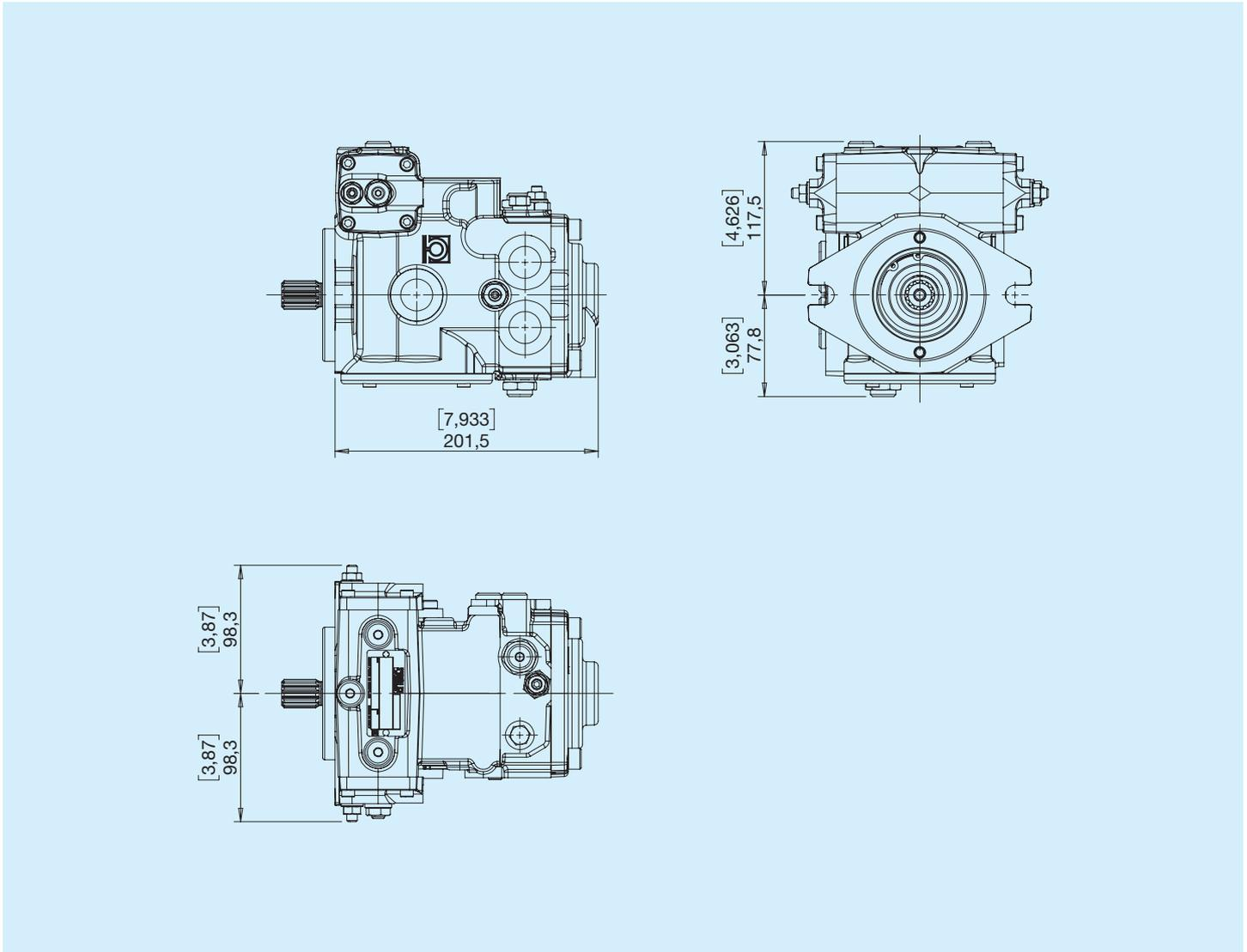

M4PV	Nominal displacement		Swash plate °	Continuous pressure		Intermittent pressure		Peak pressure		Rotational speed		Weight	
	cm ³	in ³		bar	psi	bar	psi	bar	psi	MAX min ⁻¹	MIN min ⁻¹	kg	lbs
21	21	1.28	18	250	3625	300	4350	350	5075	3600	500	20	44.0
28	28	1.71	18	250	3625	300	4350	350	5075	3600	500	20	44.0
37	37	2.26	18	250	3625	300	4350	350	5075	3400	500	21	46.2

Feed pump

Type	Standard feed pump displacement		Optional feed pump displacement		Pressure	
	cm ³	in ³	cm ³	in ³	bar	psi
M4PV21	9	0.55	12	0.74	22	319
M4PV28	9	0.55	12	0.74	22	319
M4PV37	12	0.74	-	-	22	319

B SAE B

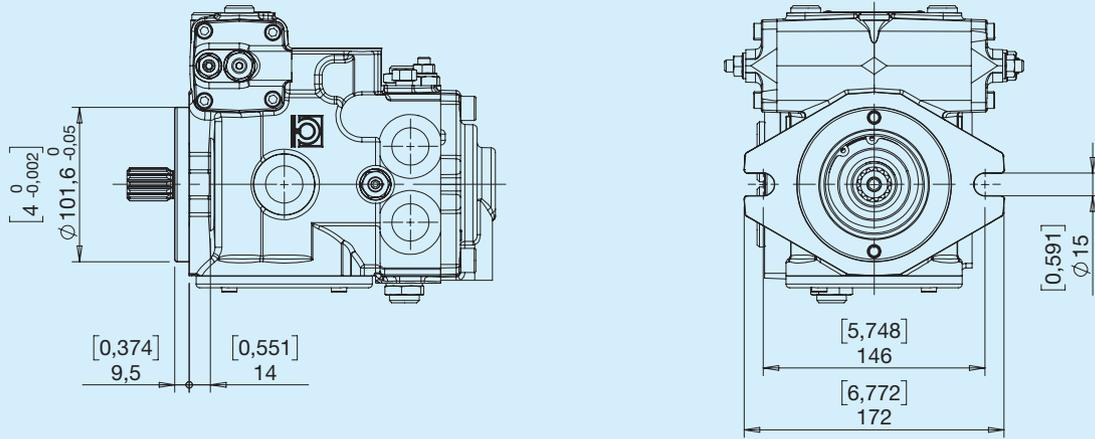

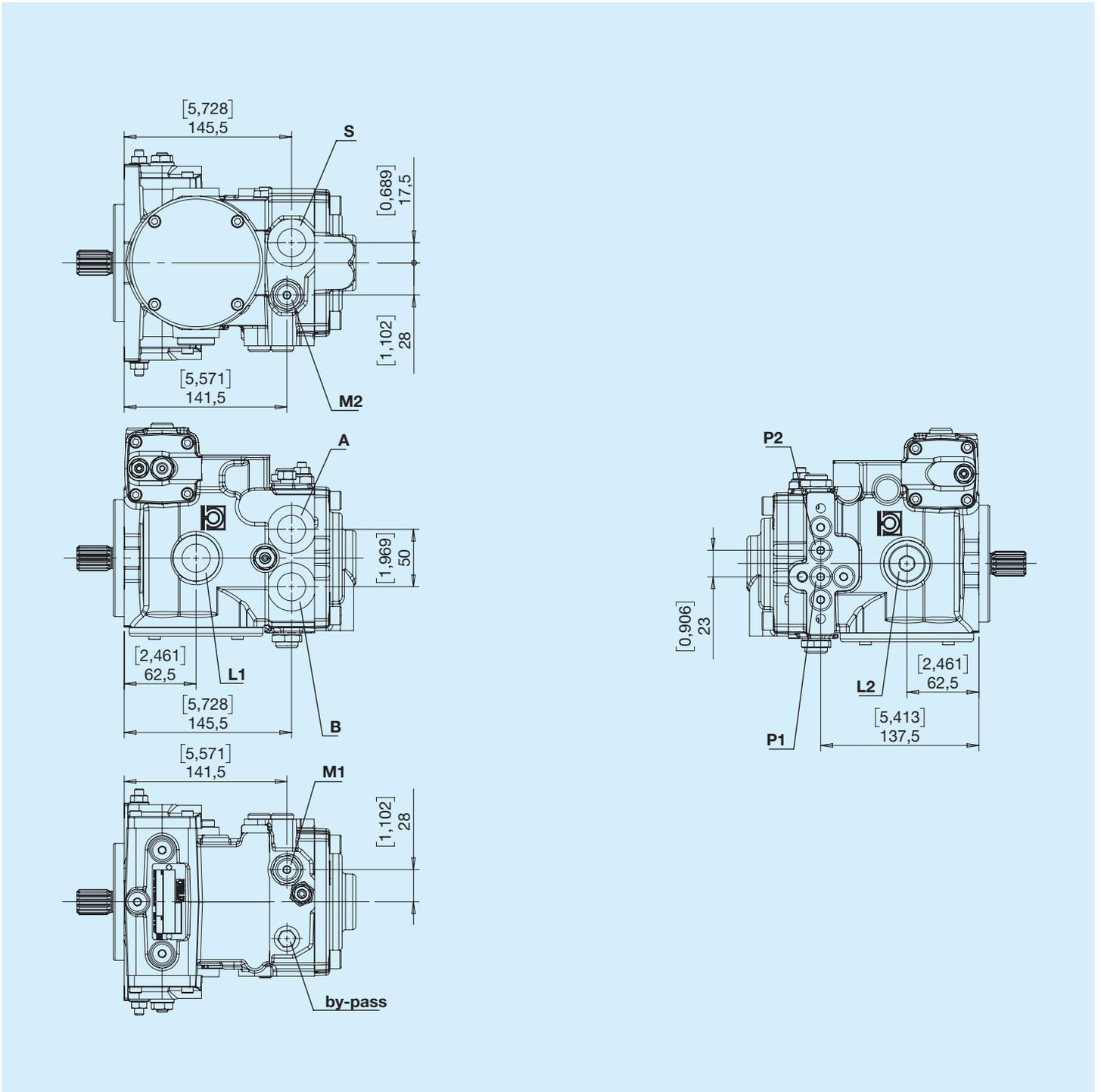

- A,B** - Use
- L1, L2** - Drain port
- S** - Inlet
- P** - Pressure intake
- M1, M2** - Manometer intake

A Automotive

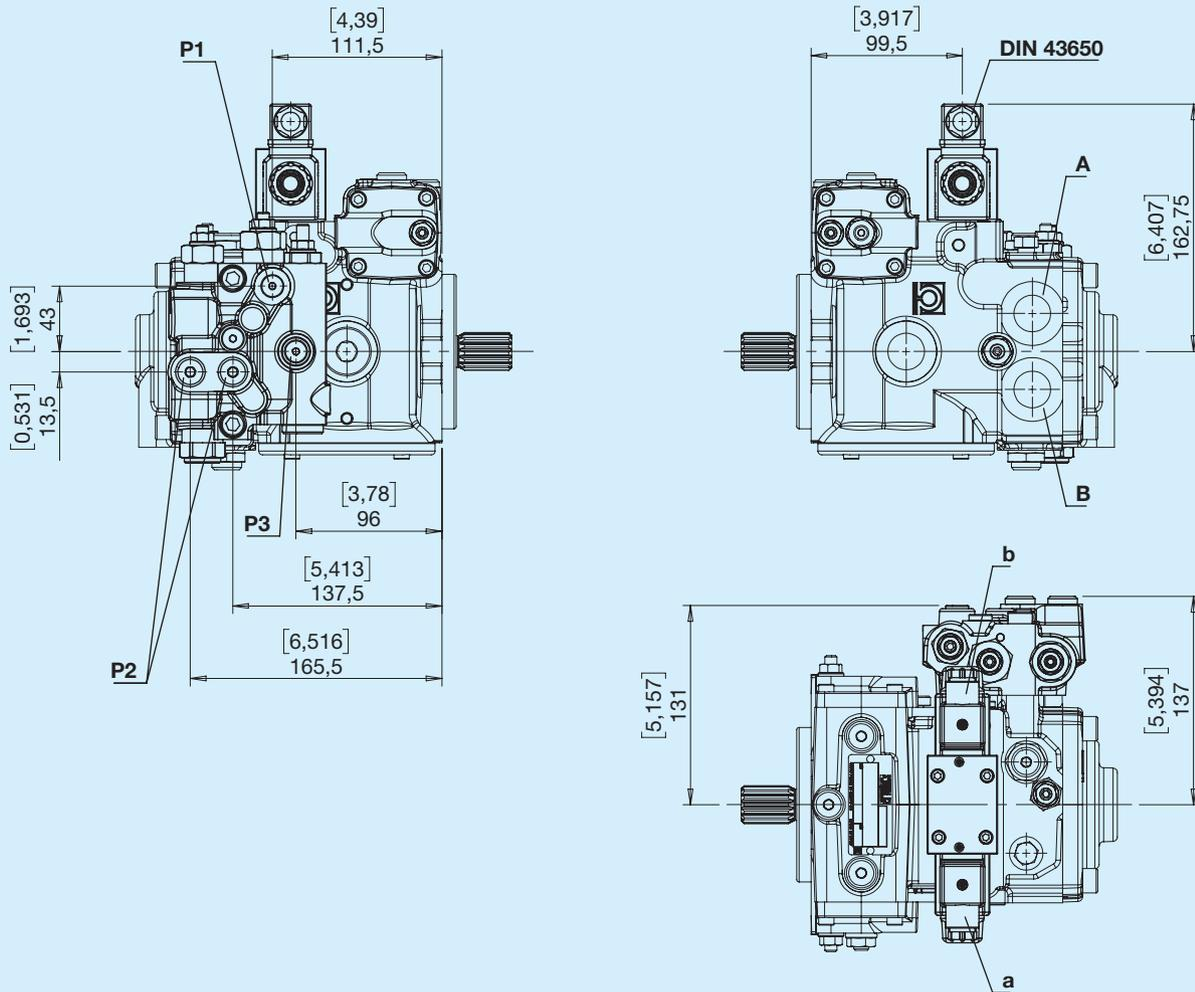

Available on request with DEUTSCH DT04-2P connectors

Outlet

Rotation	Excited solenoid	Outlet
Right	a	A
Right	b	B
Left	a	B
Left	b	A

P1, P3 - Pressure intake G 1/8
P2 - Pressure intake G 1/4

Hydraulic diagram

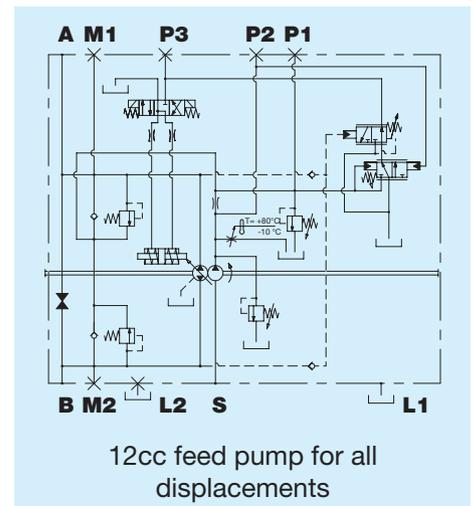

12cc feed pump for all displacements

E Electrical ON/OFF, closed centre 12V

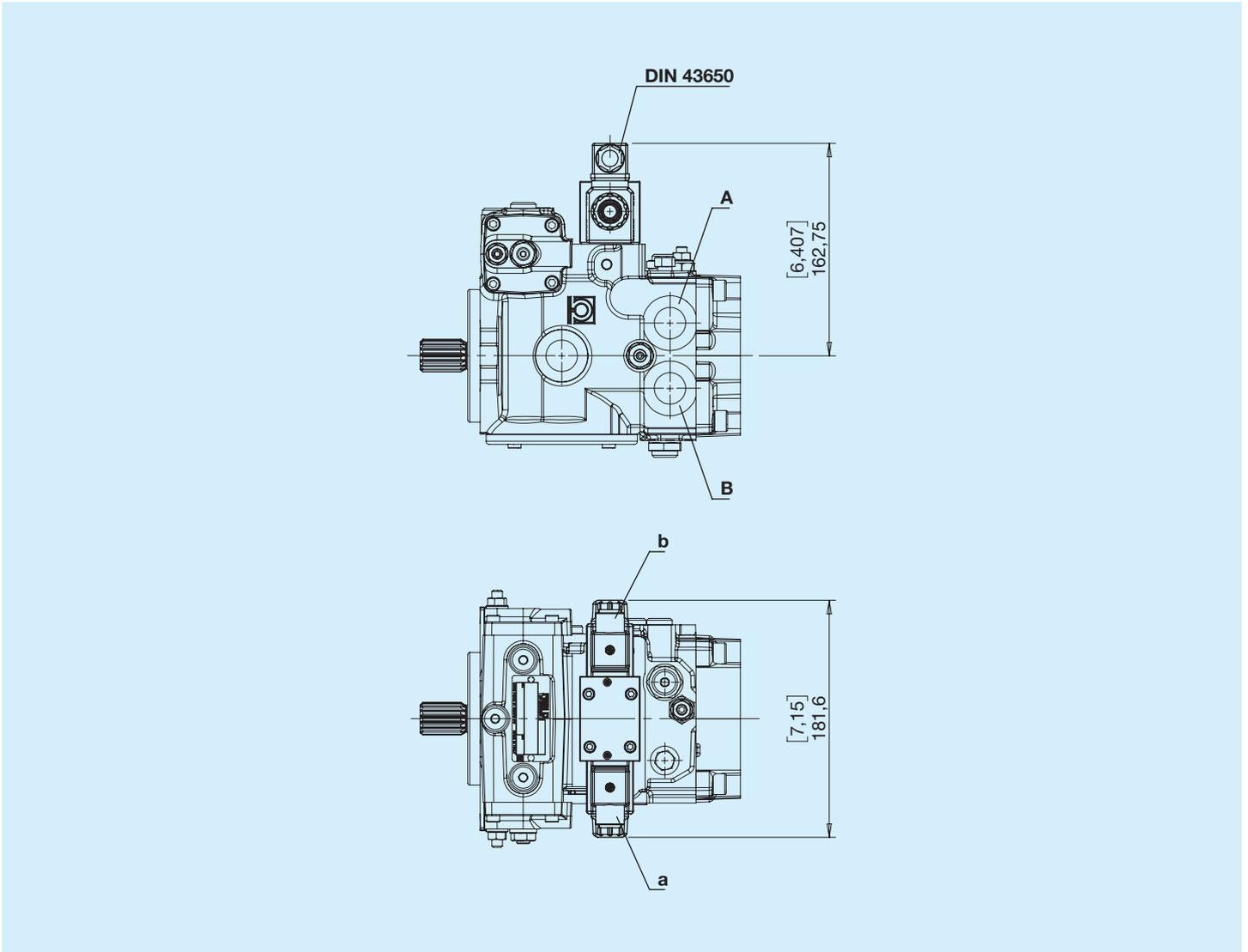

Outlet

Rotation	Excited solenoid	Outlet
Right	a	A
Right	b	B
Left	a	B
Left	b	A

Hydraulic diagram

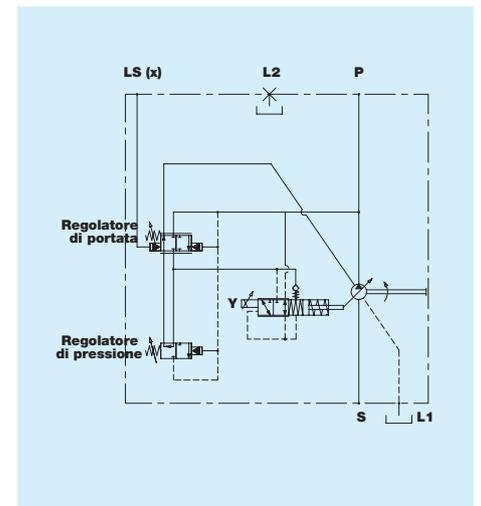

F Electrical ON/OFF, closed centre 24V

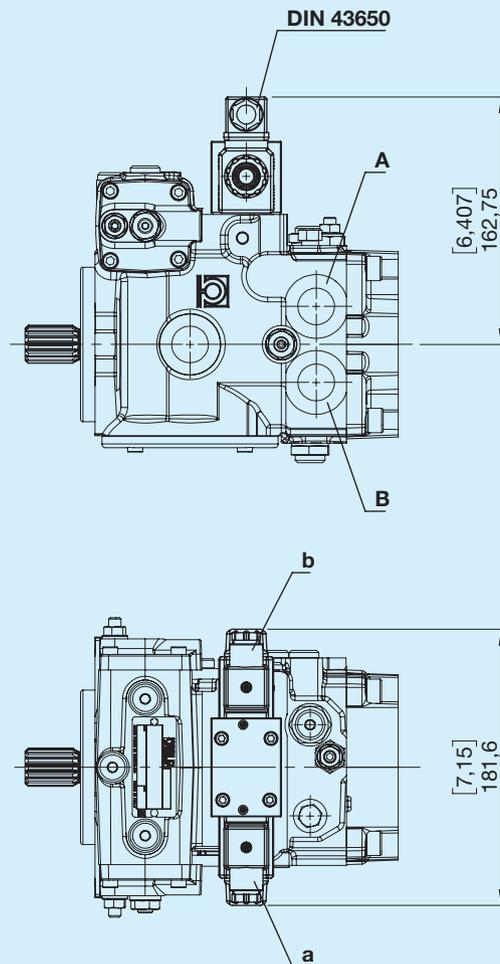

Outlet

Rotation	Excited solenoid	Outlet
Right	a	A
Right	b	B
Left	a	B
Left	b	A

Hydraulic diagram

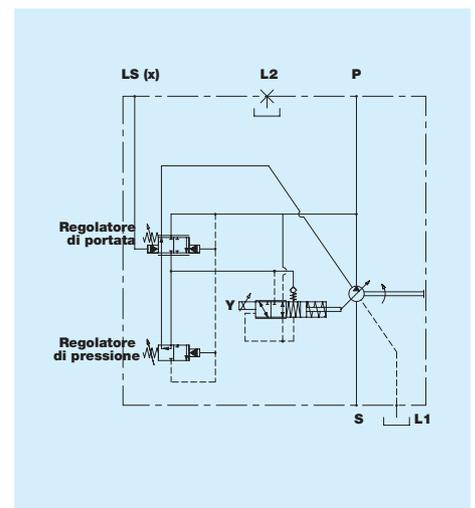

N Electrical ON/OFF, open centre 12V

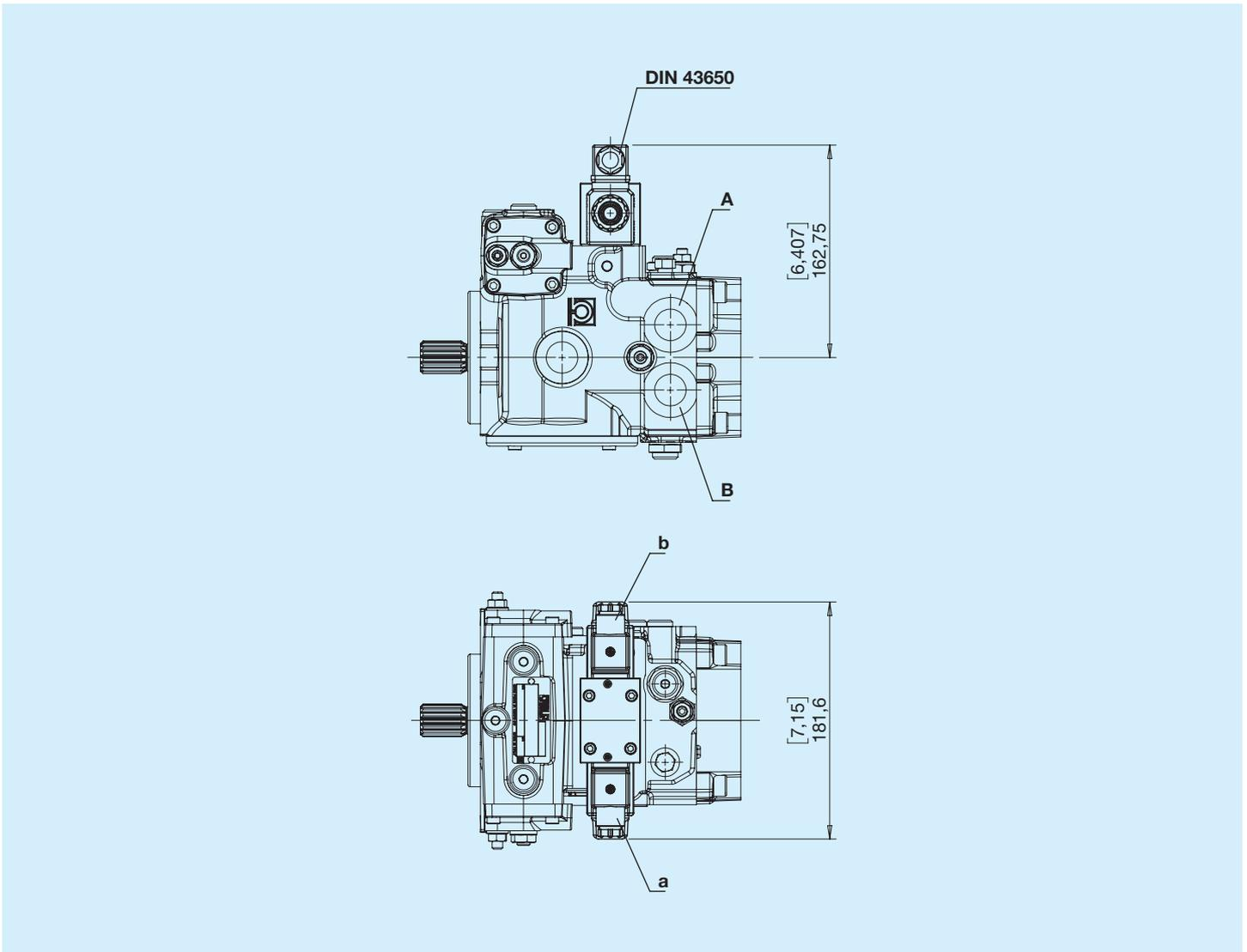

Outlet

Rotation	Excited solenoid	Outlet
Right	a	A
Right	b	B
Left	a	B
Left	b	A

Hydraulic diagram

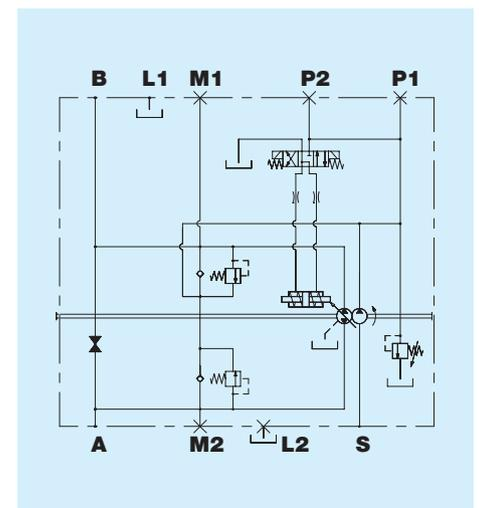

Q Electrical ON/OFF, open centre 24V

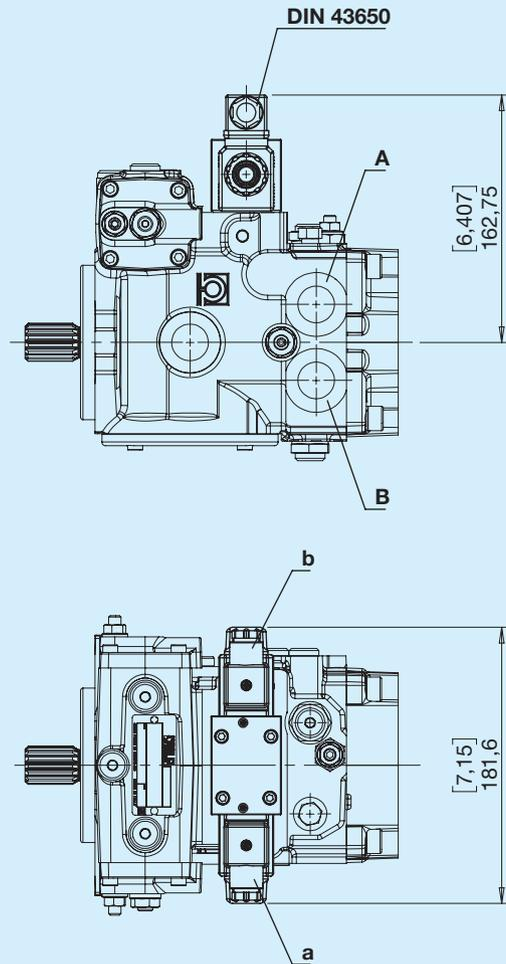

Outlet

Rotation	Excited solenoid	Outlet
Right	a	A
Right	b	B
Left	a	B
Left	b	A

Hydraulic diagram

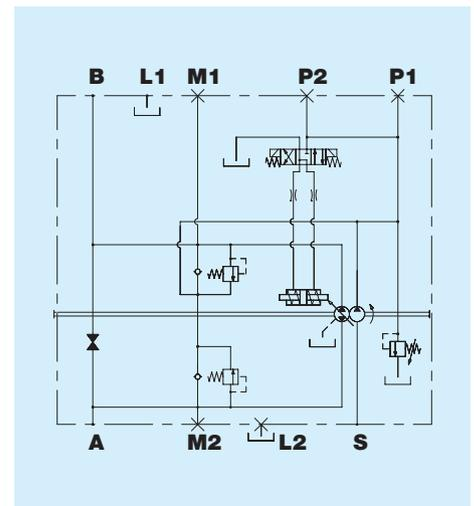

G Feedback hydraulic

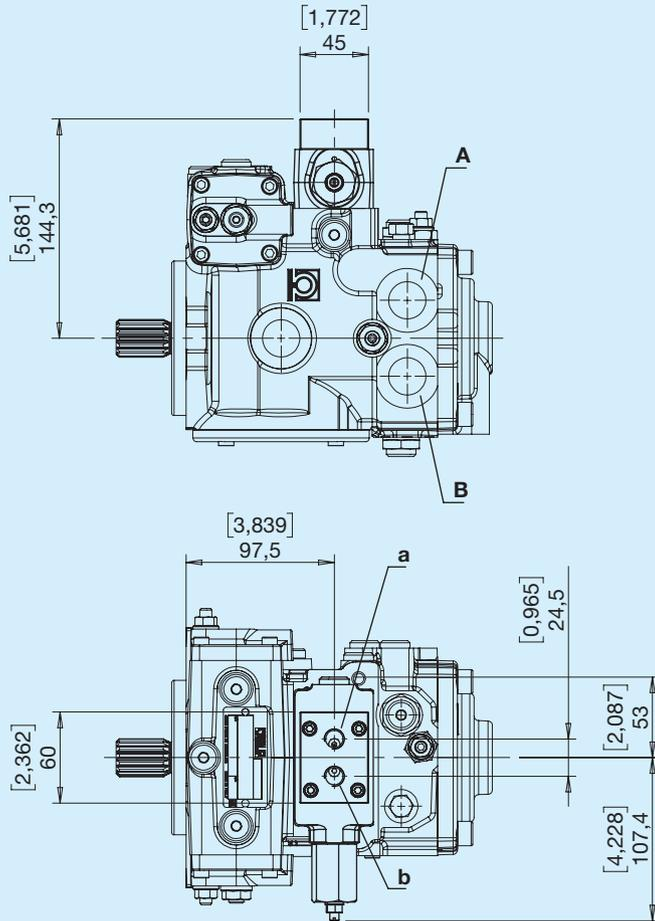

Outlet

Rotation	Pilot	Outlet
Right	a	B
Right	b	A
Left	a	A
Left	b	B

Pilot

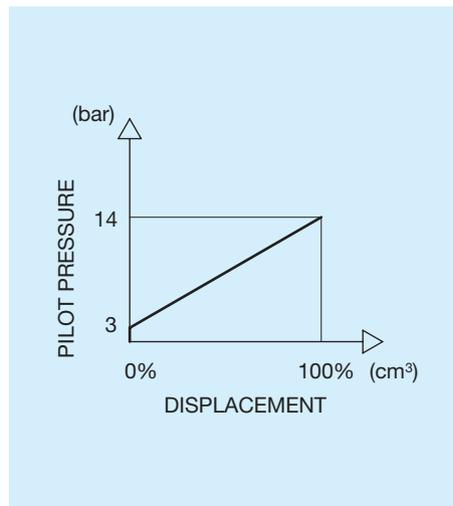

Hydraulic diagram

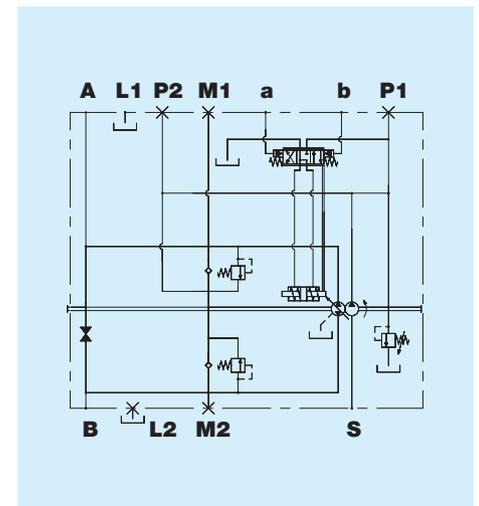

I Lever-operated hydraulic

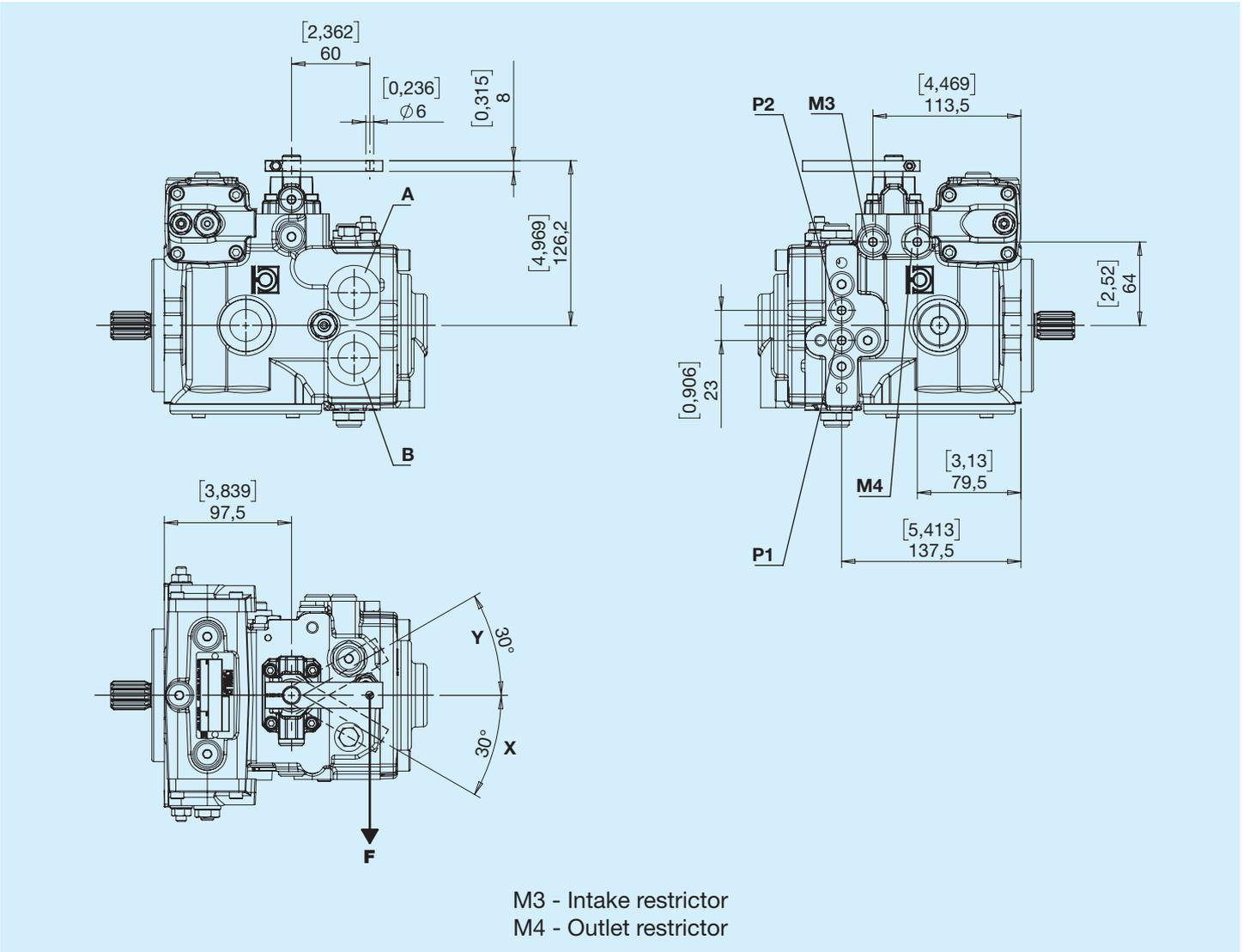

Outlet

Rotation	Control lever	Outlet
Right	Y	B
Right	X	A
Left	Y	A
Left	X	B

Pilot

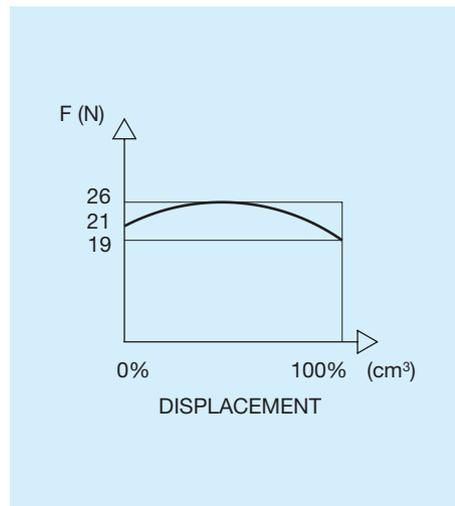

Hydraulic diagram

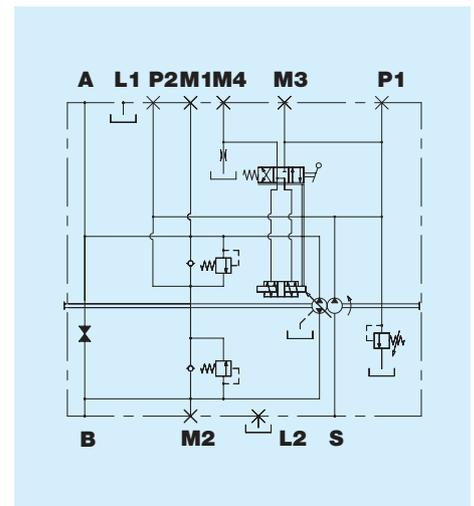

K Direct hydraulic

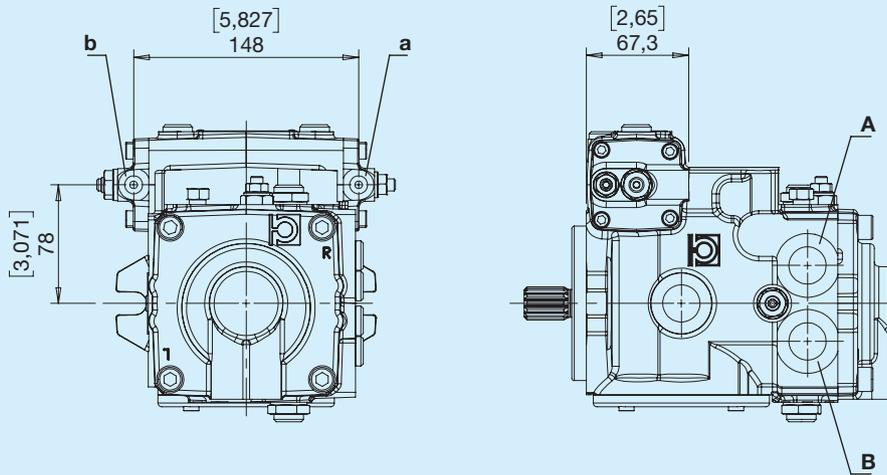

Outlet

Rotation	Pilot	Outlet
Right	a	A
Right	b	B
Left	a	B
Left	b	A

Pilot

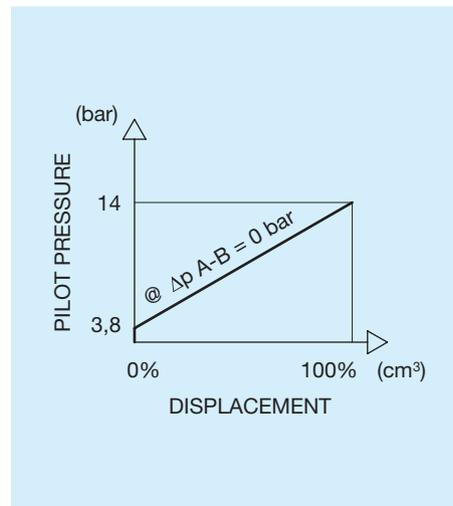

Hydraulic diagram

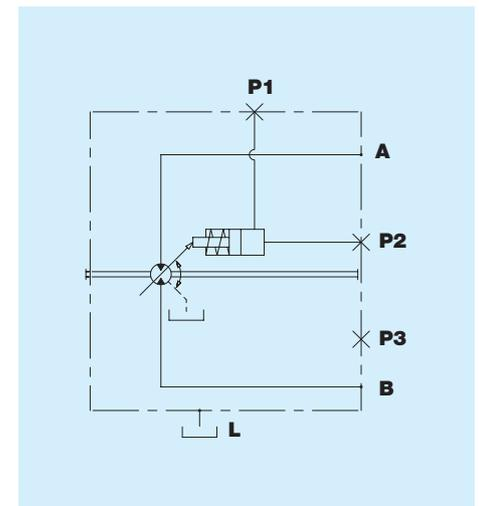

○ Electronic proportional feedback control 12V

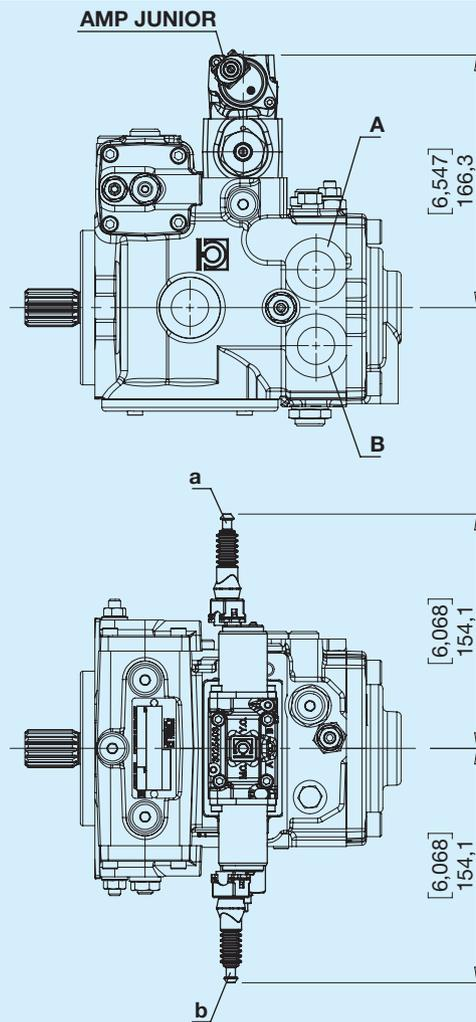

Available on request with DEUTSCH DT04-2P connectors

Outlet

Rotation	Excited solenoid	Outlet
Right	a	B
Right	b	A
Left	a	A
Left	b	B

Control

Rated voltage	12	V
Min. current (I1)	300	mA
Max. current (I2)	1500	mA
PWM frequency	100	Hz

Pilot

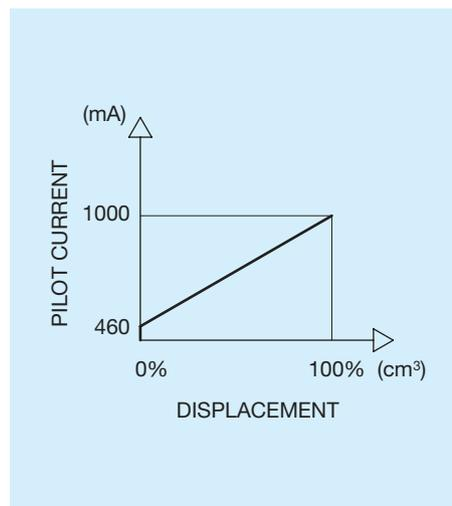

Hydraulic diagram

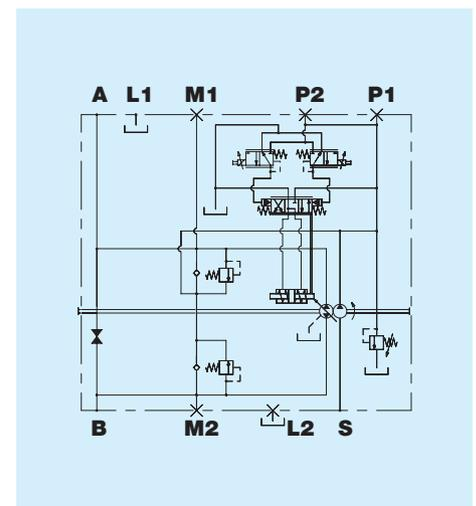

V Electronic proportional feedback control 24V

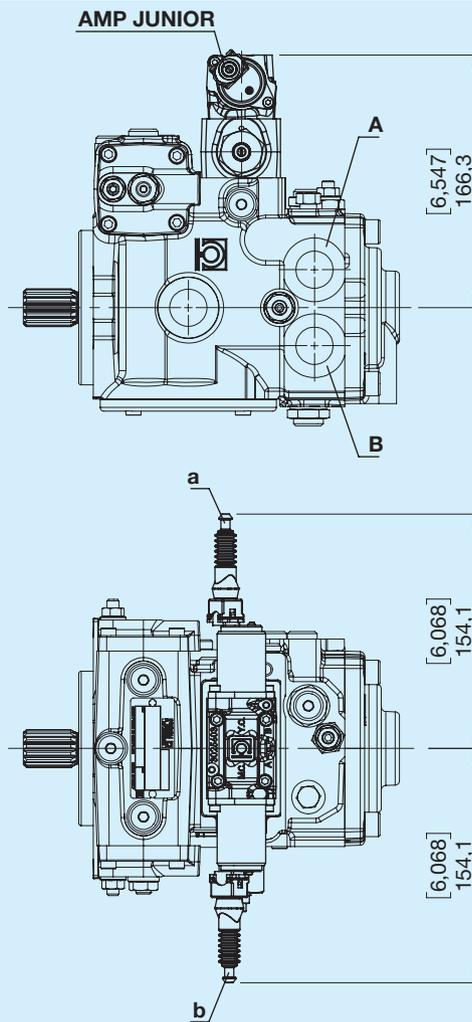

Available on request with DEUTSCH DT04-2P connectors

Outlet

Rotation	Excited solenoid	Outlet
Right	a	B
Right	b	A
Left	a	A
Left	b	B

Control

Rated voltage	24	V
Min. current (I1)	180	mA
Max. current (I2)	850	mA
PWM frequency	100	Hz

Pilot

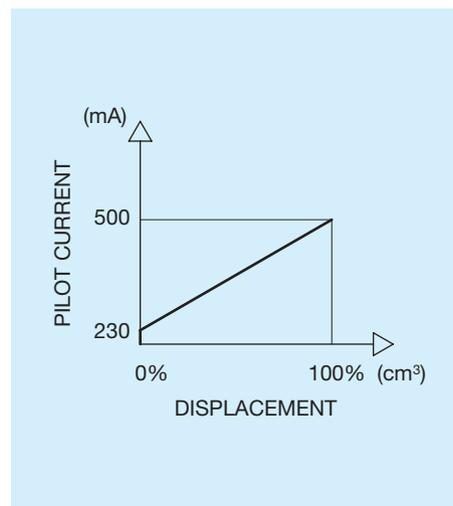

Hydraulic diagram

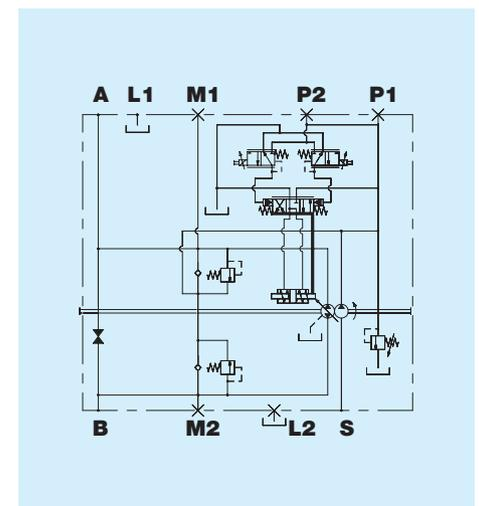

S Electronic proportional control 12V

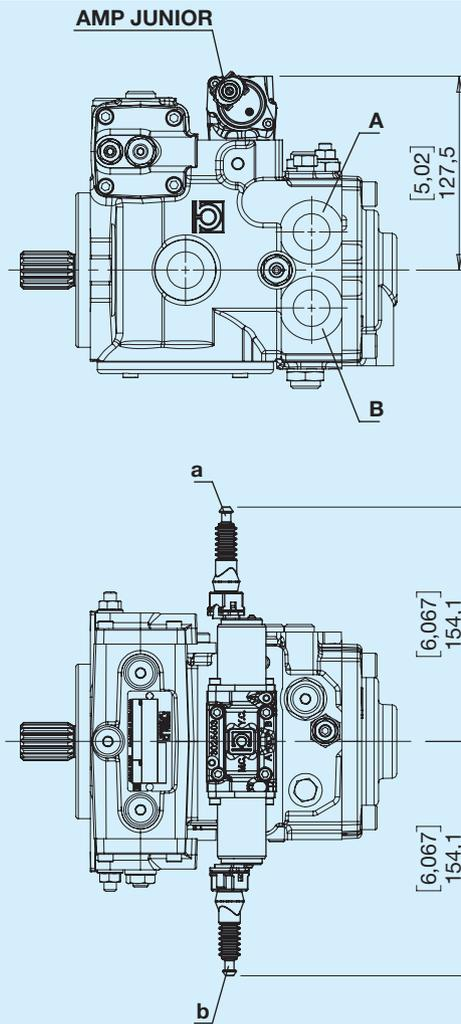

Available on request with DEUTSCH DT04-2P connectors

Outlet

Rotation	Excited solenoid	Outlet
Right	a	A
Right	b	B
Left	a	B
Left	b	A

Control

Rated voltage	12	V
Min. current (I1)	300	mA
Max. current (I2)	1500	mA
PWM frequency	100	Hz

Pilot pressure

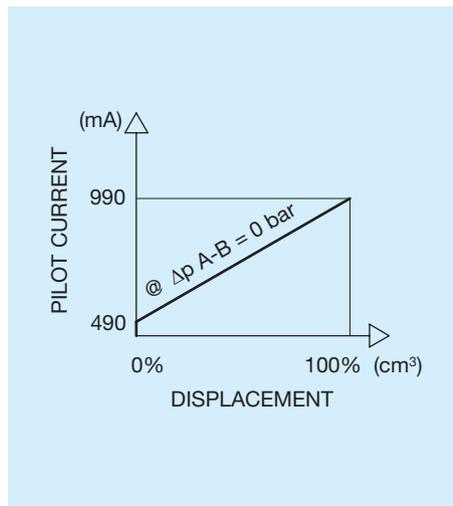

Hydraulic diagram

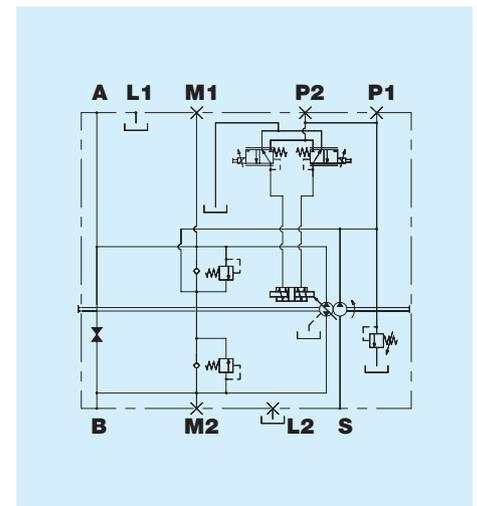

W Electronic proportional control 24V

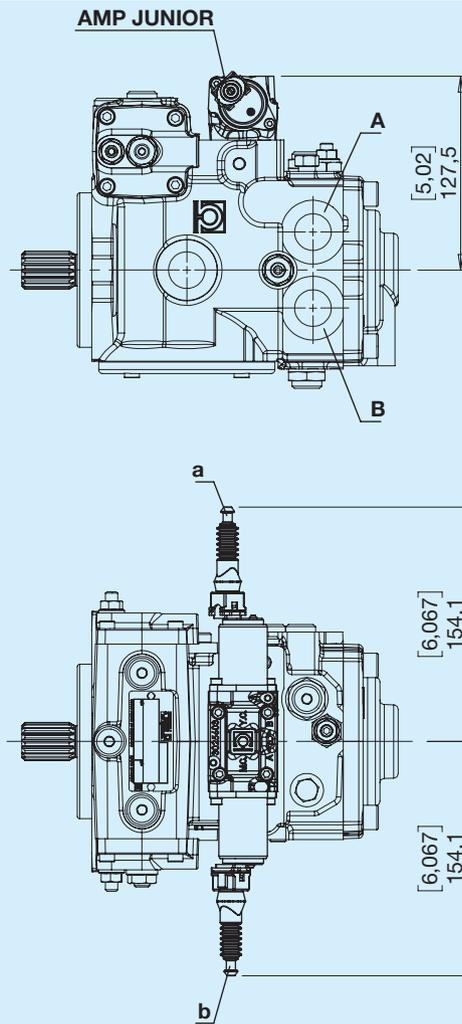

Available on request with DEUTSCH DT04-2P connectors

Outlet

Rotation	Excited solenoid	Outlet
Right	a	A
Right	b	B
Left	a	B
Left	b	A

Control

Rated voltage	24	V
Min. current (I1)	180	mA
Max. current (I2)	850	mA
PWM frequency	100	Hz

Pilot pressure

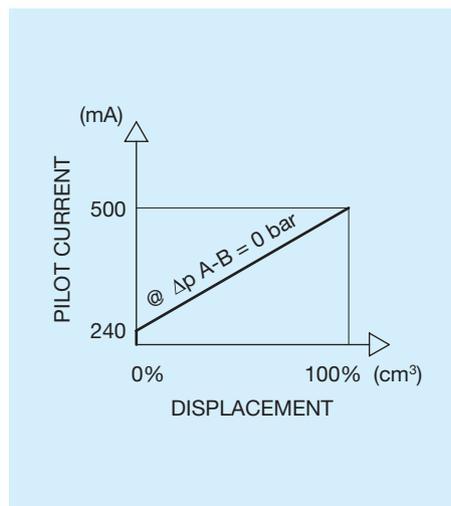

Hydraulic diagram

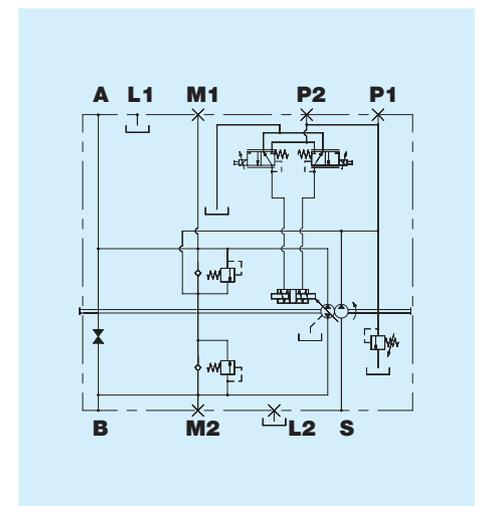

2 SAE A with boost pump

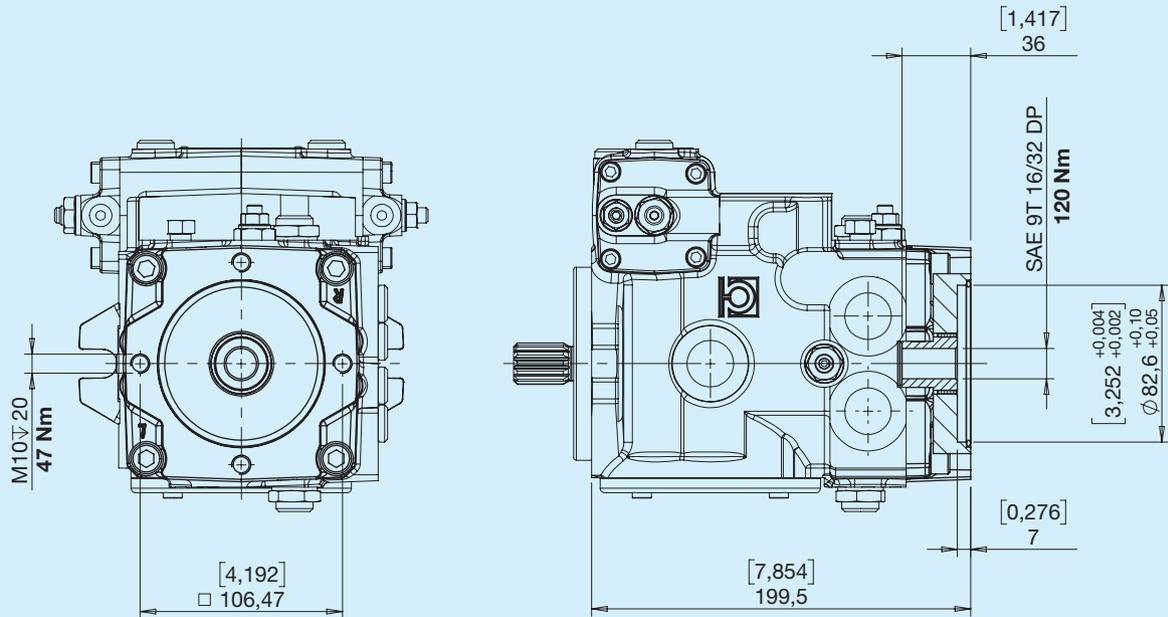

3 SAE B with boost pump

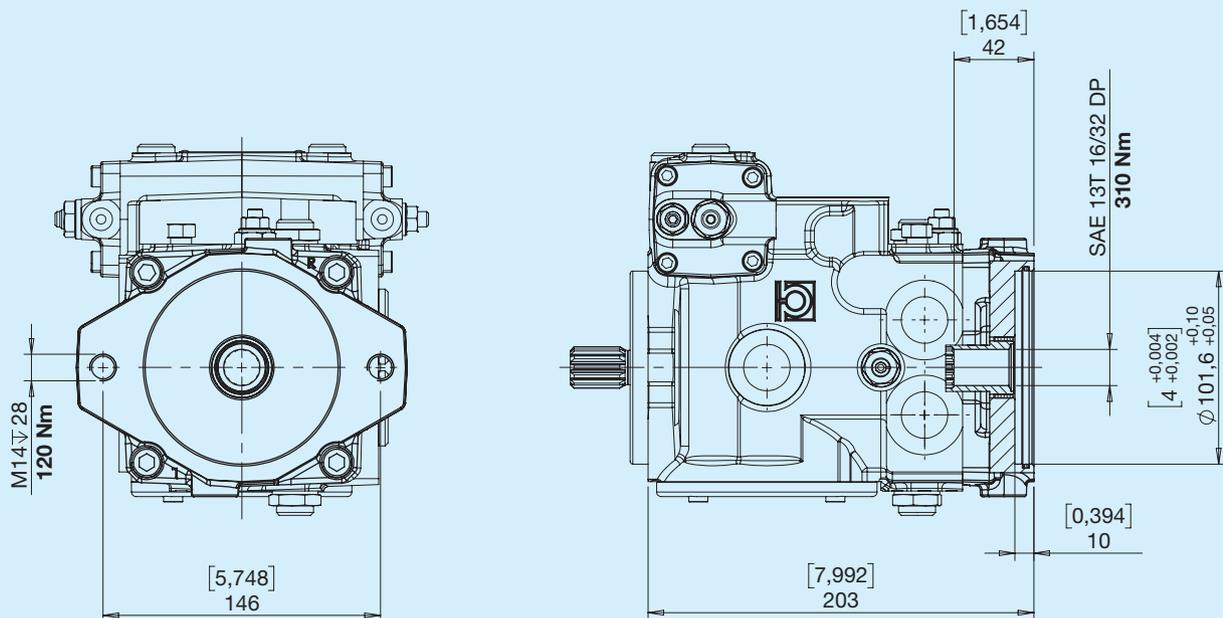

5 SAE A without boost pump

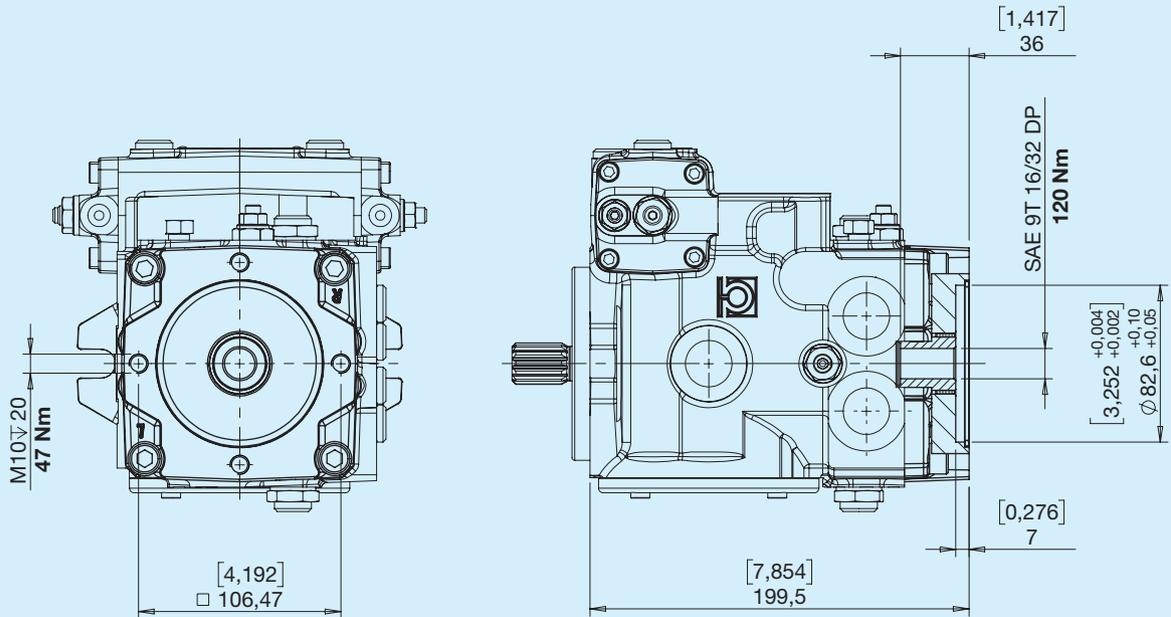

6 SAE B without boost pump

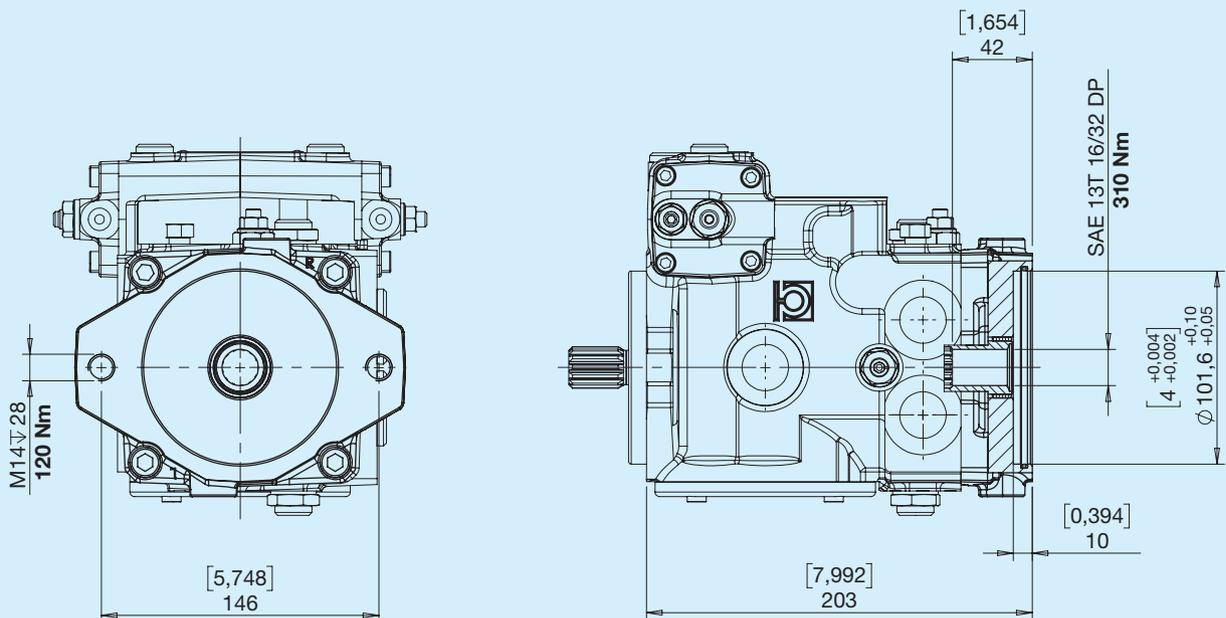

1 Cylindrical Ø22.22

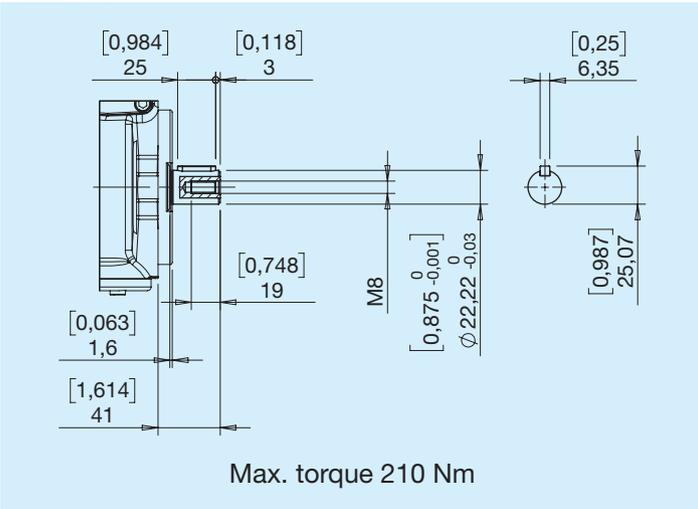

3 SAE 15T 16/32 DP

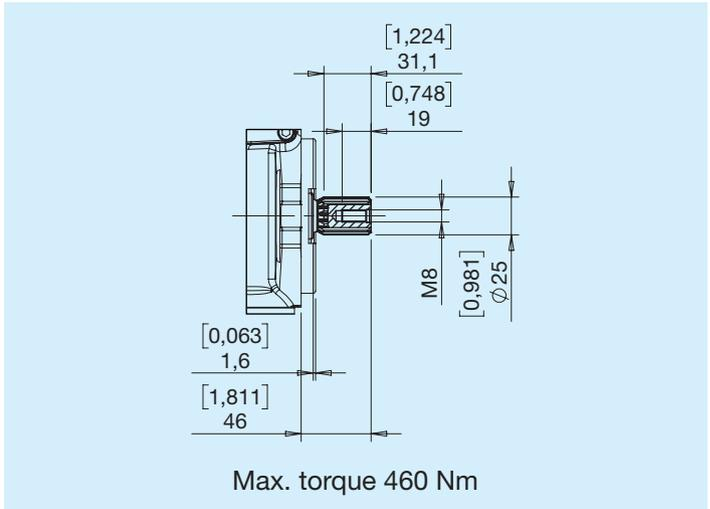

6 SAE 13T 16/32 DP

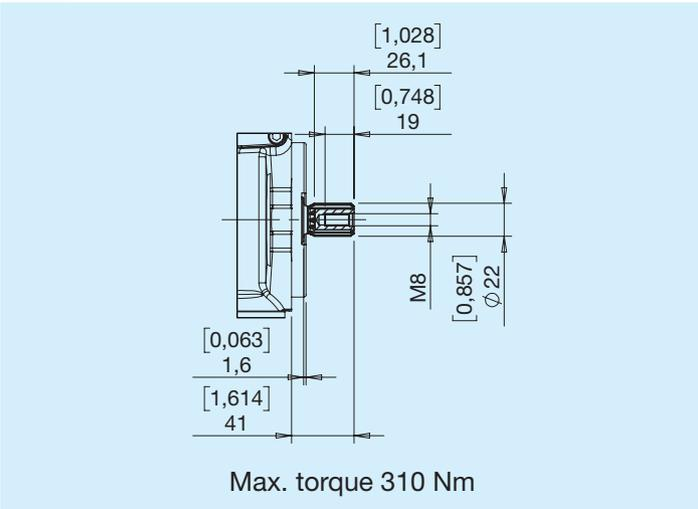

7 SAE 11T 16/32 DP

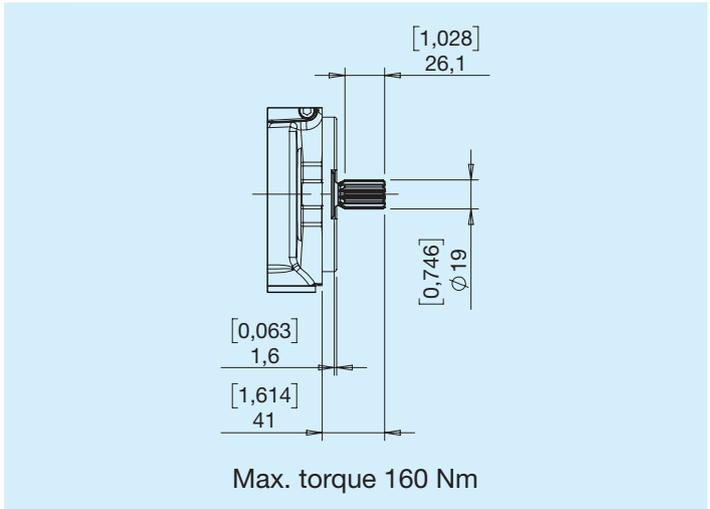

Type R

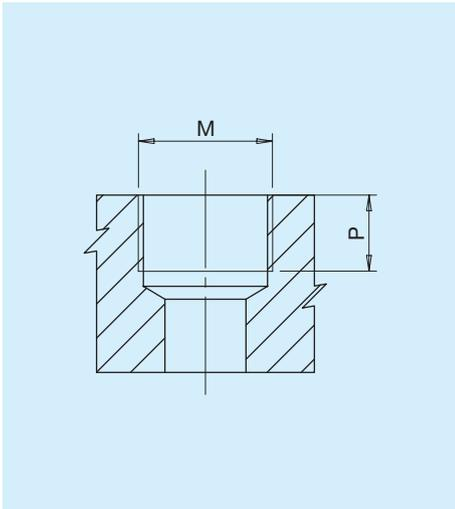

Type	M		P	
		Nm	mm	in
G2	Port ISO 1179-1 - G 1/4	17	12	0.47
G6	Port ISO 1179-1 - G 3/4	90	15	0.59

Type U

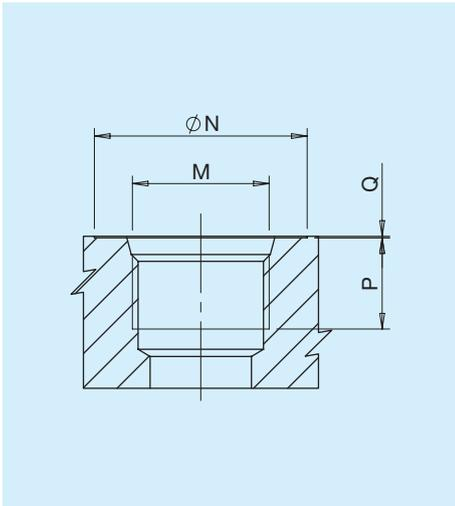

Type	Dim.	N		P		Q		M	Nm
		mm	in	mm	in	mm	in		
U2	1/4"	20	0,79	12	0,47	0,3	0,01	Port ISO 11926-1-7/16-20	17
U6	3/4"	42	1.65	18	0.70	0.3	0.01	Port ISO 11926-1-1 1/16-12	90

Combinations

Type	Inlet S	Outlet A-B	Drain port L1-L2	Pilot pressure a-b	Pressure intakes P1 - P2	Manometer intakes M1 - M2
R	G6	G6	G6	G2	G2	G2
U	U6	U6	U6	G2	G2	U2

E 'no operator' safety

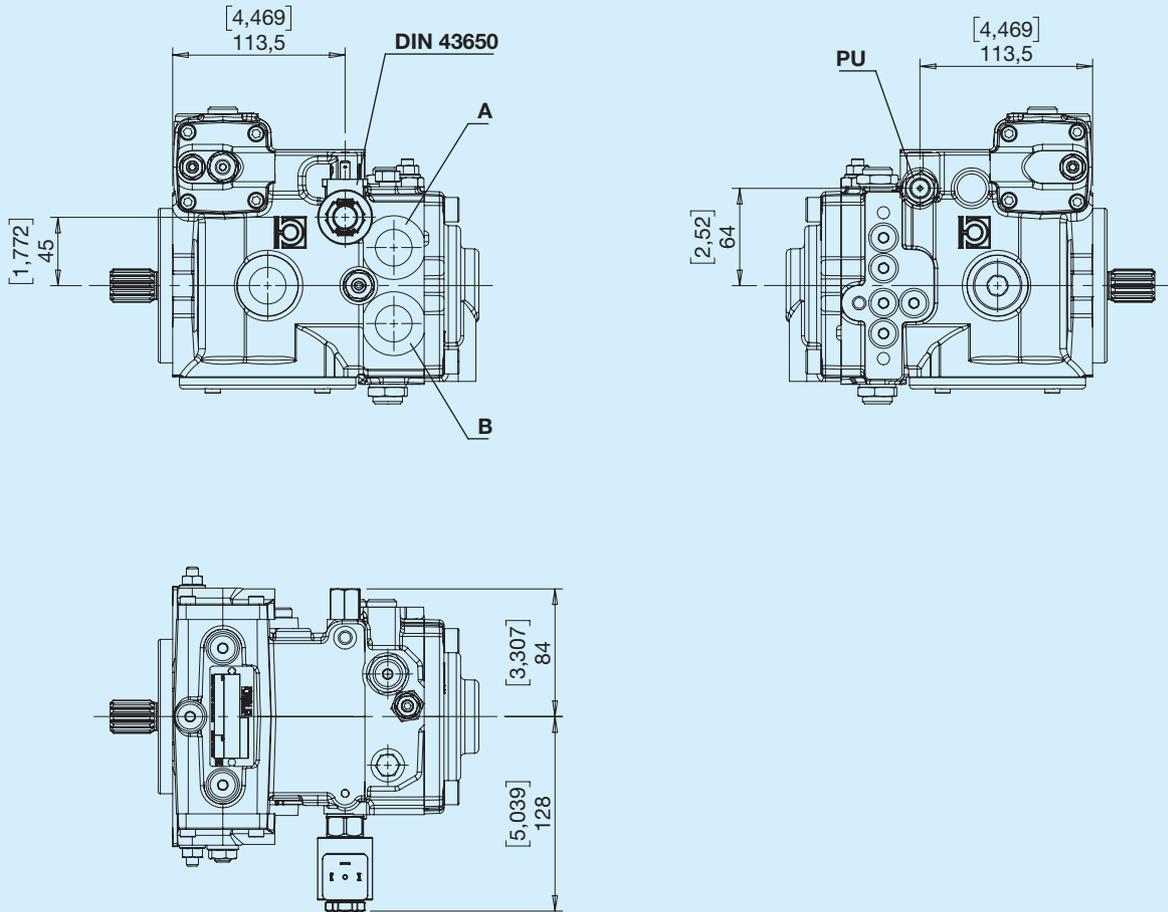

PU - Brake opening pressure G1/4

Hydraulic diagram

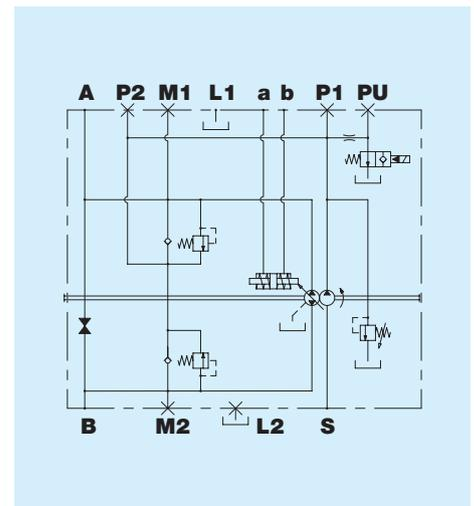

H Hydraulic inching (only A control)

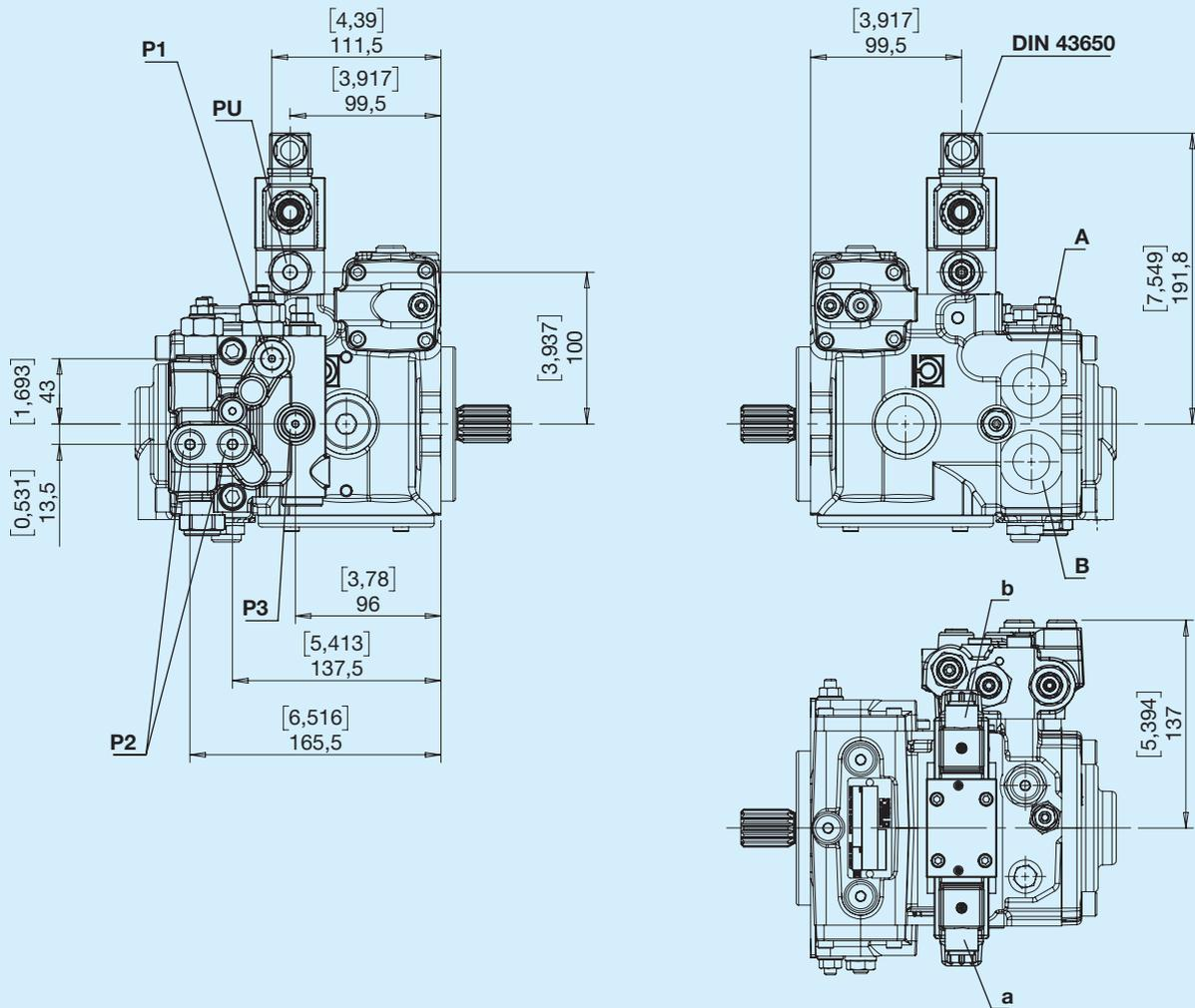

Available on request with DEUTSCH DT04-2P connectors

Hydraulic diagram

Right
Right
Left

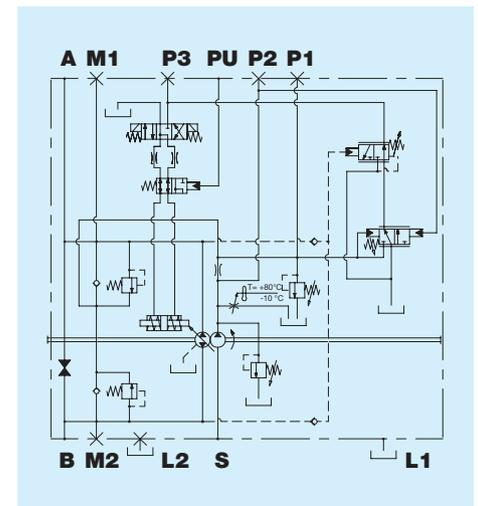

J Cut-off

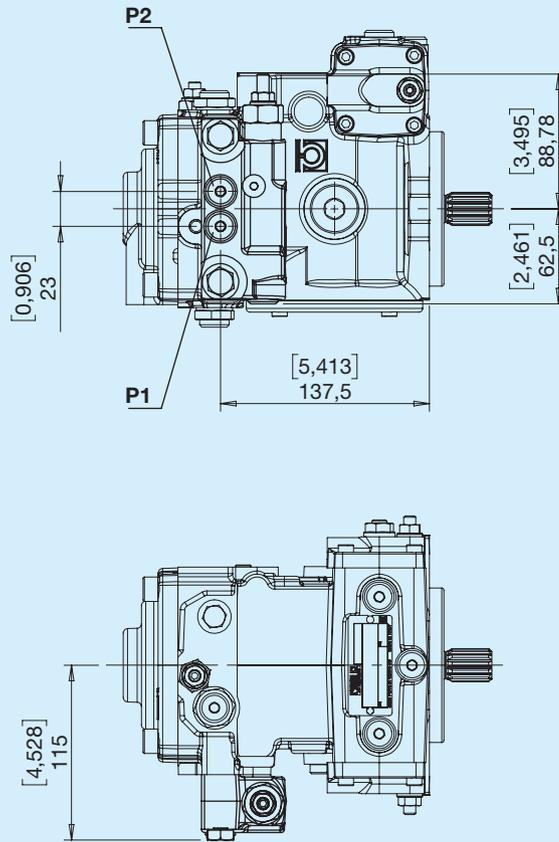

P1, P2 - Pressure intake G1/4

Hydraulic diagram

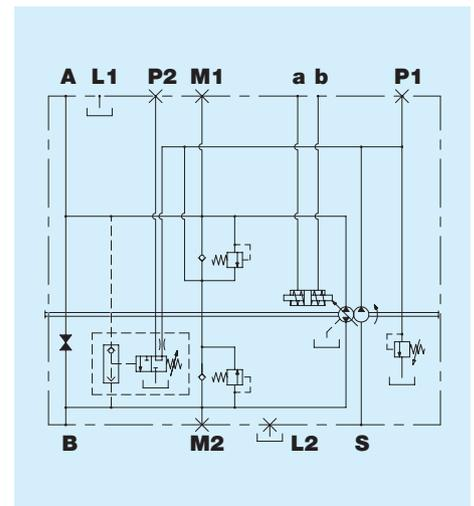

M Mechanical inching (only A control)

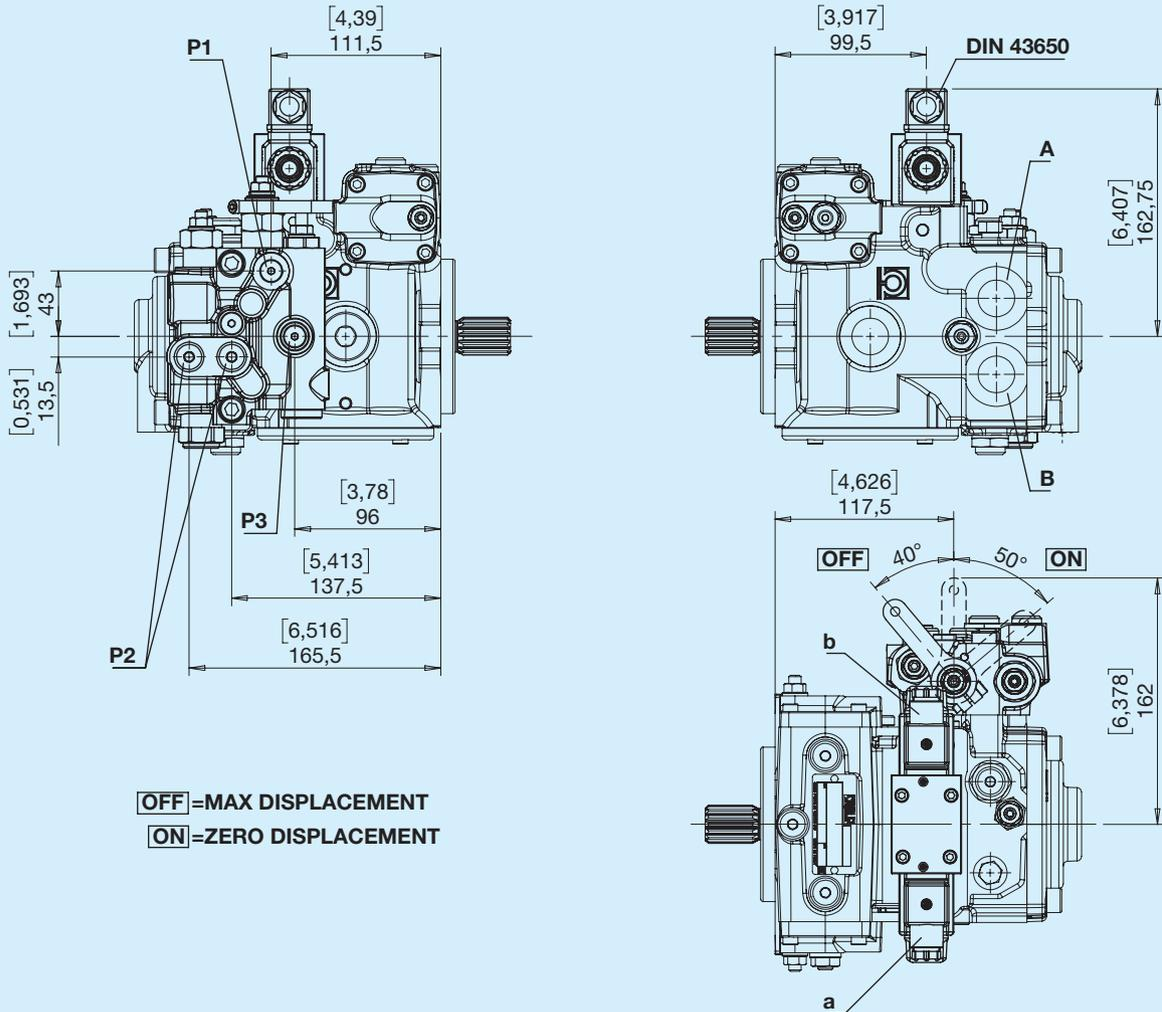

Available on request with DEUTSCH DT04-2P connectors

Hydraulic diagram

P1, P3 - Pressure intake G 1/8
P2 - Pressure intake G 1/4

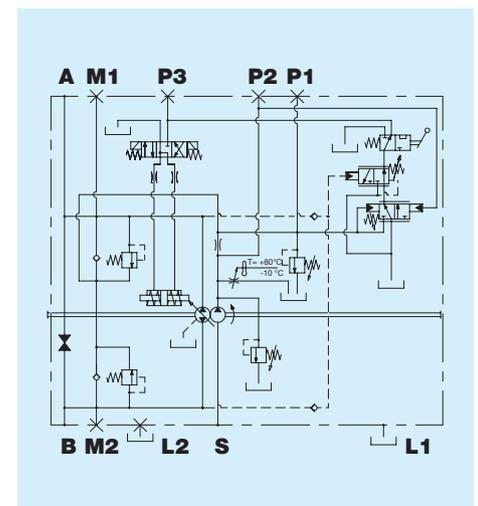

V Flushing valve (5-7 l/min)

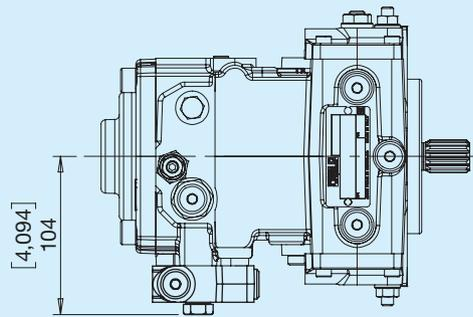
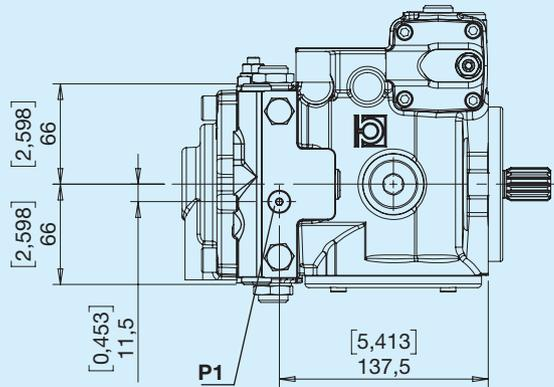

P1 - Pressure intake G1/8

Hydraulic diagram

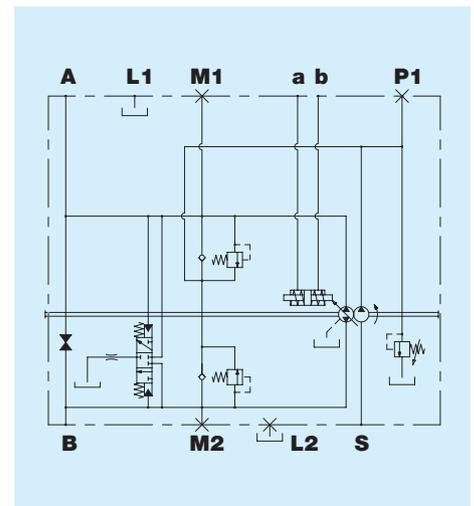

W Power limiter

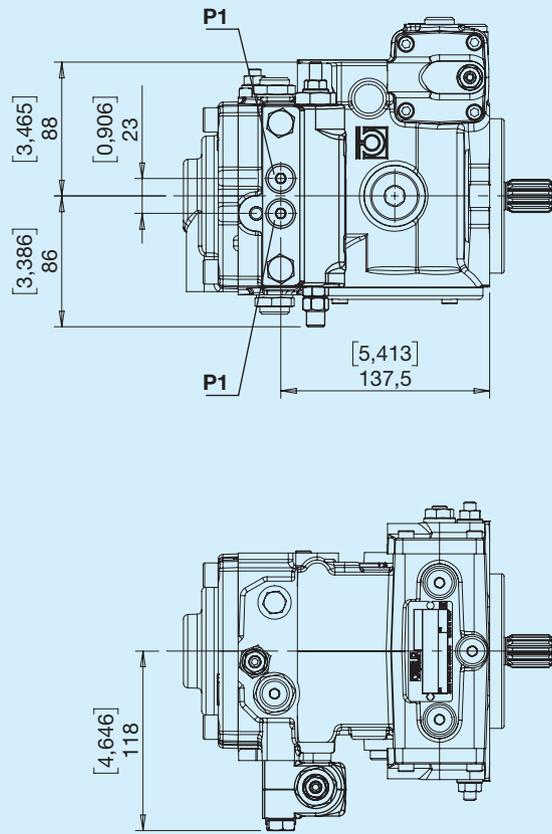

P1, P2 - Pressure intake G1/4

Hydraulic diagram

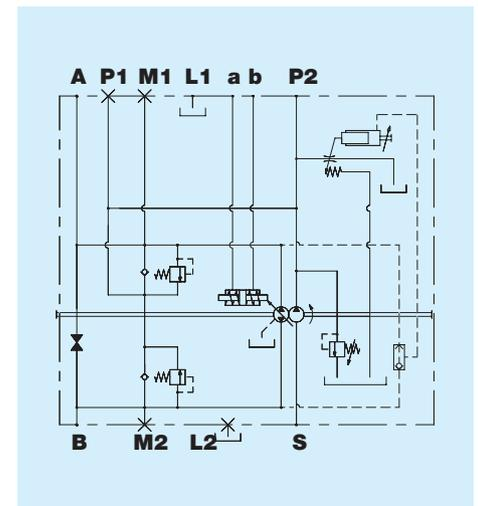

X Filter with clogging indicator

Electric differential indicator - 30 VDC - 0.2 A max

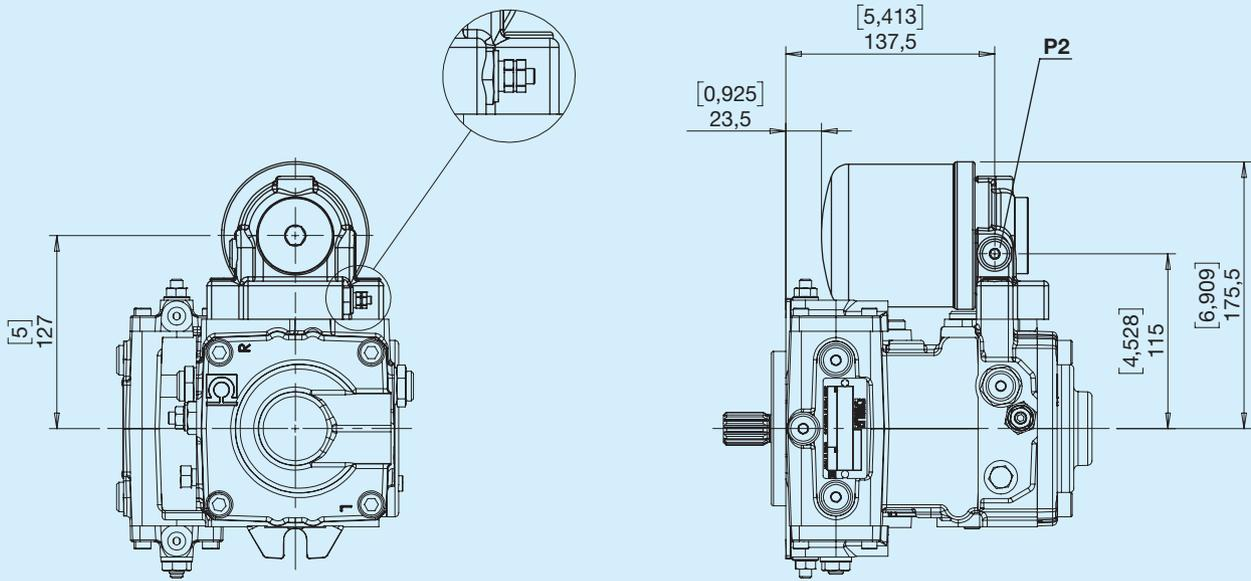

PU - Filtered oil intake G1/4

Hydraulic diagram

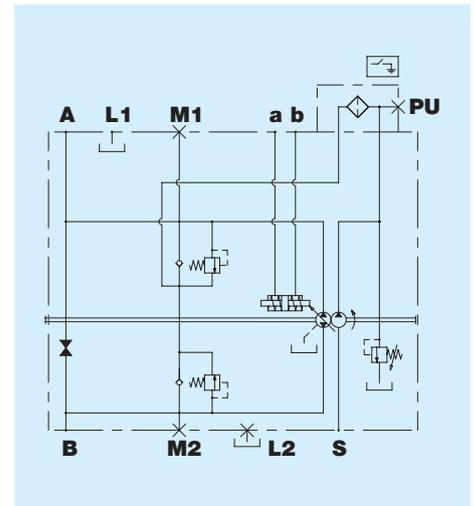

Y Filter without clogging indicator

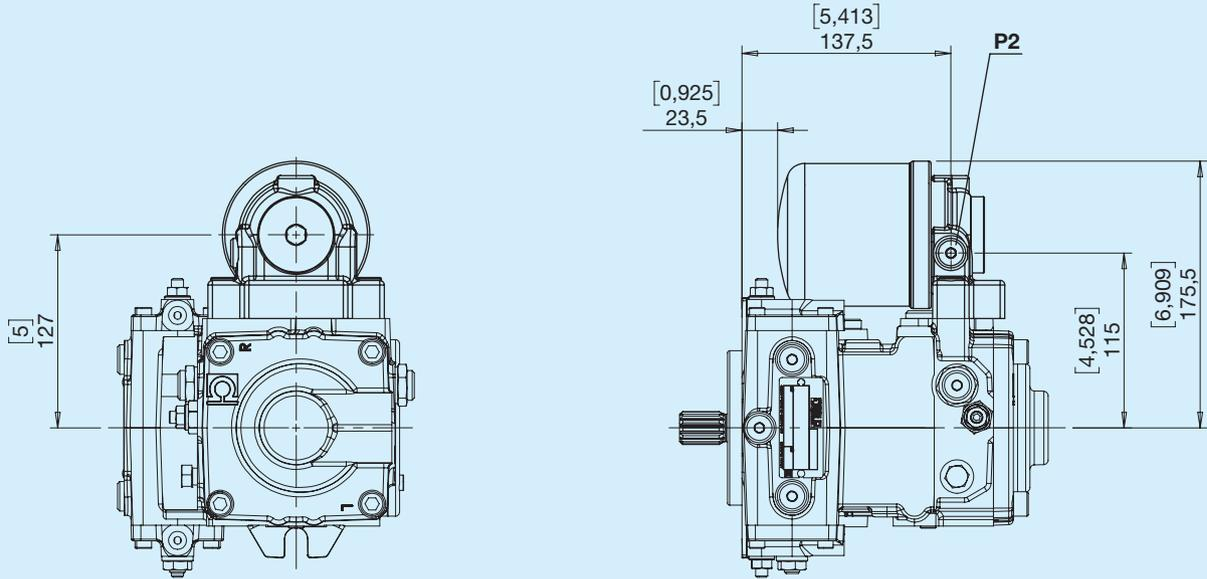

PU - Filtered oil intake G1/4

Hydraulic diagram

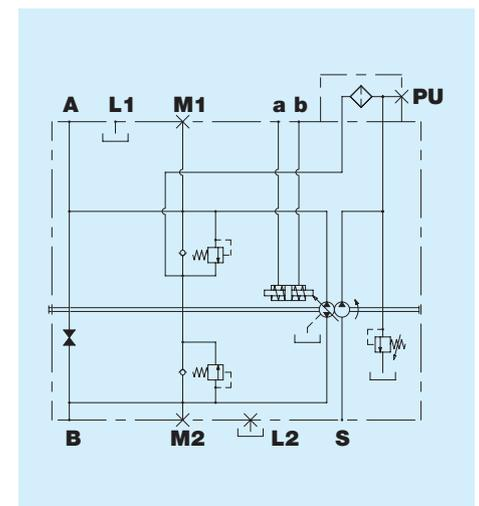



1 2	Nominal displacement	
21	28	37

3 4	Displacement	
21	28	37

5	Controls						
A	Automotive	N	Electrical ON/OFF, open centre 12V	I	Lever-operated hydraulic	V	Electronic proportional feedback control 24V
E	Electrical ON/OFF, closed centre 12V	Q	Electrical ON/OFF, open centre 24V	K	Remote hydraulic	S	Electronic proportional control 12V
F	Electrical ON/OFF, closed centre 24V	G	Feedback hydraulic	O	Electronic proportional feedback control 12V	W	Electronic proportional control 24V

6	Versions						
1	No special fittings, with boost pump	4	No special fittings, without boost pump	S	Primary SHORT pump with boost pump	U	Secondary SHORT pump with SAE A fitting
2	SAE A with boost pump	5	SAE A without boost pump	T	Primary SHORT pump without boost pump	W	Secondary SHORT pump with SAE B fitting
3	SAE B with boost pump	6	SAE B without boost pump	Y	Secondary SHORT pump without fitting		

7	Valve calibration						
B	150 bar	E	210 bar	I	280 bar	O	350 bar
D	180 bar	G	250 bar	L	300 bar	P	400 bar

8	Swashplate type		
A	Mounted on needle bearings	B	Mounted on bronze bearings

9	Direction of rotation		
R	Right	L	Left

10	Shaft profile				
1	Cylindrical Ø22.22	6	SAE 13T 16/32 DP	0	For secondary SHORT pump
3	SAE 15T 16/32 DP	7	SAE 11T 16/32 DP		

11	By-pass	
B	By-pass	

12	Type of ports		
R	Gas	U	UNF

13	Accessories						
O	No option	J	Cut-off	W	Power limiter	S	Multiple accessories
E	'no operator' safety	M	Mechanical inching (only A control)	X	Filter with electric clogging indicator		
H	Hydraulic inching (only A control)	V	Flushing valve	Y	Filter without electric clogging indicator		

14 15 16	Special versions	
...		

Double pump, short version

The order code of a short multiple pump is obtained, as shown in the examples, by summing the codes of the individual pumps (stages) obtained by following the order instructions for the single pumps

Stage 1
Stage 2
M4PV 28 28 K S G A R 3 B R 0 000 + **M4PV 28 28 K Y G A R 0 BR 0 000**

short pump

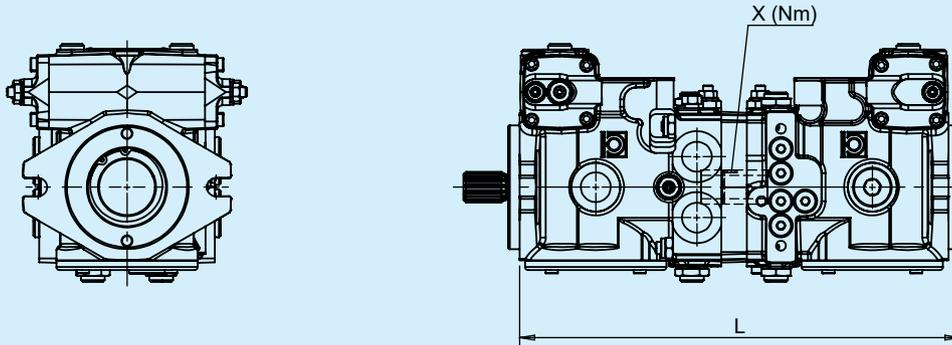

	L		Feed pump		X Torque Nm
	mm	in	cm ³	in ³	
M4PV21 28	361.5	14.23	12	0.74	140
M4PV37	363.5	14.31	14	0.86	240

Stage 1
Stage 2
M4PV 28 28 K S G A R 3 B R 0 000 + **M4PV 28 28 K U G A R 0 BR 0 000**

short pump with SAE A fitting

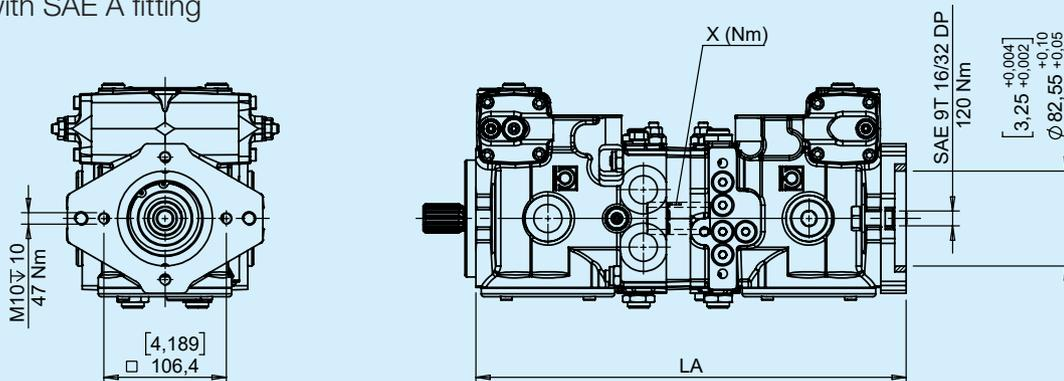

	LA		Feed pump		X Torque Nm
	mm	in	cm ³	in ³	
M4PV21 28	374	14.72	12	0.74	140
M4PV37	376	14.80	14	0.86	240

Stage 1
Stage 2
M4PV 28 28 K S G A R 3 B R 0 000 + M4PV 28 28 K W G A R 0 B R 0 000

short pump with SAE B fitting

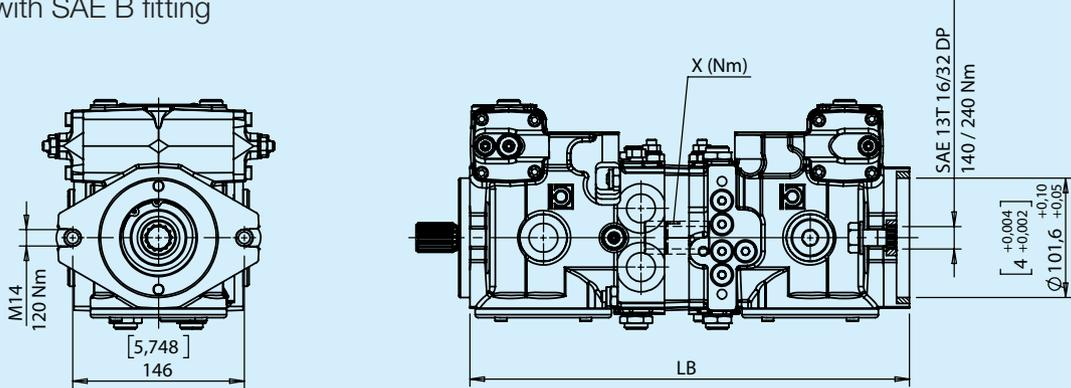

	LB		Feed pump		X Torque Nm
	mm	in	cm ³	in ³	
M4PV21 28	374	14.72	12	0.74	140
M4PV37	376	14.80	14	0.86	240