

SCATOLE INGRANAGGI
GEARBOXES
GETRIEBE

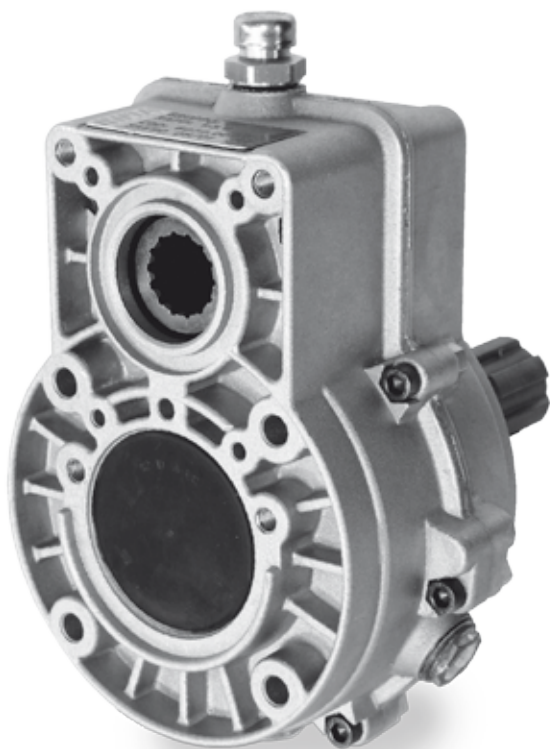

SCATOLE PER POMPE OLEODINAMICHE
GEARBOX FOR HYDRAULIC GEAR PUMPS
GETRIEBE FÜR ÖLKRAFTZAHNRADERPUMPEN





⚠ **ATTENZIONE!**
Gli alberi contrassegnati non sono protetti. Ogni componente in rotazione deve avere una protezione specifica o integrata con la macchina. Bima declina ogni responsabilità in caso le idonee protezioni non siano previste e mantenute efficienti.

⚠ **WARNING!**
Rotating shafts marked are not shielded. Any shaft and coupling not guarded by location must be shielded by an interactive guarding system. Bima declines responsibility if proper guards are not provided and maintained.

⚠ **ACHTUNG!**
Die mit gekennzeichneten Wellen sind freiliegend. Jedes drehende Bauteil muss einen spezifischen oder in die Maschine integrierten Schutz haben. Bei nicht geeigneten oder unzureichend instandgehaltenen Schutzvorrichtungen lehnt Bima jegliche Verantwortung ab.

SCATOLE PER POMPE OLEODINAMICHE GEARBOX FOR HYDRAULIC GEAR PUMPS GETRIEBE FÜR ÖLKRAFTZAHNRADERPUMPEN

I moltiplicatori prendono il moto normalmente dalla presa di forza di una trattoria agricola o da un albero cardanico e lo trasmettono a pompe oleodinamiche, portandole al regime di rotazione ottimale per il loro corretto funzionamento.

Possono funzionare con prese di moto a 540 e a 1000 min⁻¹; regimi d'entrata più elevati sono ammessi a condizione che la velocità di uscita dei moltiplicatori non superi i 3000 min⁻¹.

I valori di coppia riportati nelle tabelle sono riferiti a condizioni di lavoro continuo e possono essere superati del 25% in condizioni di servizio intermittente.

Le temperature di esercizio ammesse sono comprese tra i -20°C e gli 80°C.

Una lubrificazione corretta è fondamentale per il buon funzionamento e per una durata adeguata del moltiplicatore.

Il livello dell'olio può essere controllato tramite l'apposita spia di livello.

Si consiglia di sostituire l'olio dopo le prime 50 ore di funzionamento e successivamente ogni 1500 ore di lavoro non superando i 12 mesi tra i vari cambi.

Speed increasers are normally used to drive hydraulic pumps from agricultural tractor PTOs or drive shafts, increasing the shaft r.p.m. to the optimum speed for pump operation.

They can be fitted to PTOs operating at 540 or 1000 min⁻¹: higher input speeds are acceptable provided that the increaser output speed does not exceed 3000 min⁻¹.

The torque values shown in the table are for continuous operation and may be exceeded by 25% for intermittent duty.

The increasers can operate at temperatures from -20°C to 80°C.

Correct lubrication is essential to ensure trouble-free operation and a long working life.

The oil level can be checked using the sight glass.

Change the oil after the first 50 operating hours and then every 1500 hours (or every 12 months).

Übersetzungsgetriebe werden normalerweise von der Zapfwelle eines Schleppers oder einer Gelenkwelle angetrieben und übertragen diese Bewegung an Hydraulikpumpen, bringen sie somit auf die für einen ordnungsgemäßen Betrieb erforderliche Drehzahl.

Den Antrieb erhalten sie von Zapfwellen auf 540 und 1000 min⁻¹. Höhere Antriebsdrehzahlen sind insofern zulässig, als die Abtriebsdrehzahl der Übersetzungsgetriebe 3000 min⁻¹ nicht überschreitet.

Die in den Tabellen verzeichneten Drehmomentwerte beziehen sich auf einen kontinuierlichen Betrieb, bei Intermittierbetrieben ist eine Zunahme von 25% gestattet.

Die zulässige Betriebstemperatur liegt zwischen -20°C und +80°C.

Voraussetzung für den ordnungsgemäßen Betrieb und hohe Lebensdauer der Übersetzungsgetriebe ist eine vorschriftsmäßige Schmierung.

Der Ölstand läßt sich im Schauglas Das Öl nach den ersten 50 Betriebsstunden auswechseln, anschließend alle 1500 Betriebsstunden. Auf jeden Fall aber nicht mehr als 12 Monate zwischen zwei Ölwechseln verstreichen lassen.

**SCATOLE PER POMPE OLEODINAMICHE
GEARBOX FOR HYDRAULIC GEAR PUMPS
GETRIEBE FÜR ÖLKRAFTZAHNRADERPUMPEN**

MP10

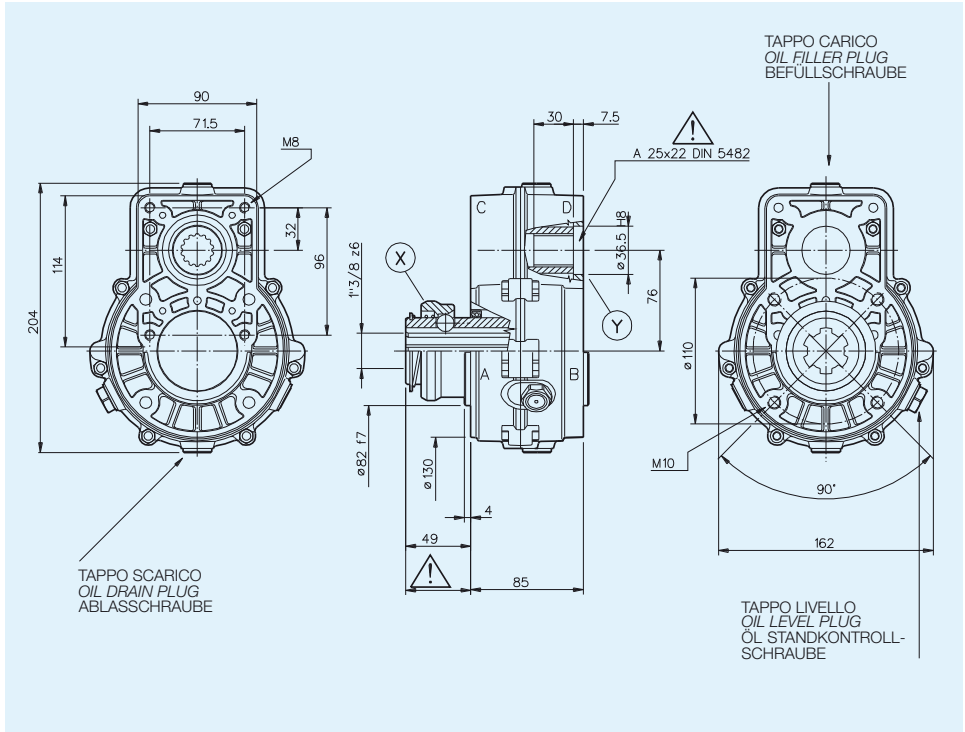

RAPPORTO RATIO VERHÄLTNIS	INGRESSO INPUT EINGANG			USCITA OUTPUT AUSGANG		MONTAGGIO ARRANGEMENT MONTAGE	ENTRATA INPUT EINGANG	CODICE CODE BESTELLNUMMER
	min ⁻¹	POTENZA POWER LEISTUNG CV	kW	COPPIA TORQUE DREHM. N-m	COPPIA TORQUE DREHM. N-m			
1:1,5	540	14	10.3	186	124	810	X	6072.002.015
1:2	540	14	10.3	186	93	1080	X	6072.002.020
1:3	540	14	10	182	60	1620	X	6072.002.030
1:3,35	540	14	10.3	186	55	1809	X	6072.002.033
1:3,8	540	12	8.8	159	42	2052	X	6072.002.038

PESO INDICATIVO APPROXIMATE WEIGHT GEWICHT CA.	OLIO CONSIGLIATO RECOMMENDED OIL EMPFOHLENES ÖL	MATERIALI MATERIALS WERKSTOFF			CUSCINETTI BEARINGS NADELLAGER				
		SCATOLA CASE GEHAUSE	ALBERI SHAFTS WELLEN	INGRANAGGI GEARS VERZÄHNUNG	A	B	C	D	E
Kg.	SAE 90 Kg.								
5	0,14	GDAISI 12	20MnCr5	20MnCr5	6010	6010	6007	6007	

**SCATOLE PER POMPE OLEODINAMICHE
GEARBOX FOR HYDRAULIC GEAR PUMPS
GETRIEBE FÜR ÖLKRAFTZAHNRADERPUMPEN**

MP10

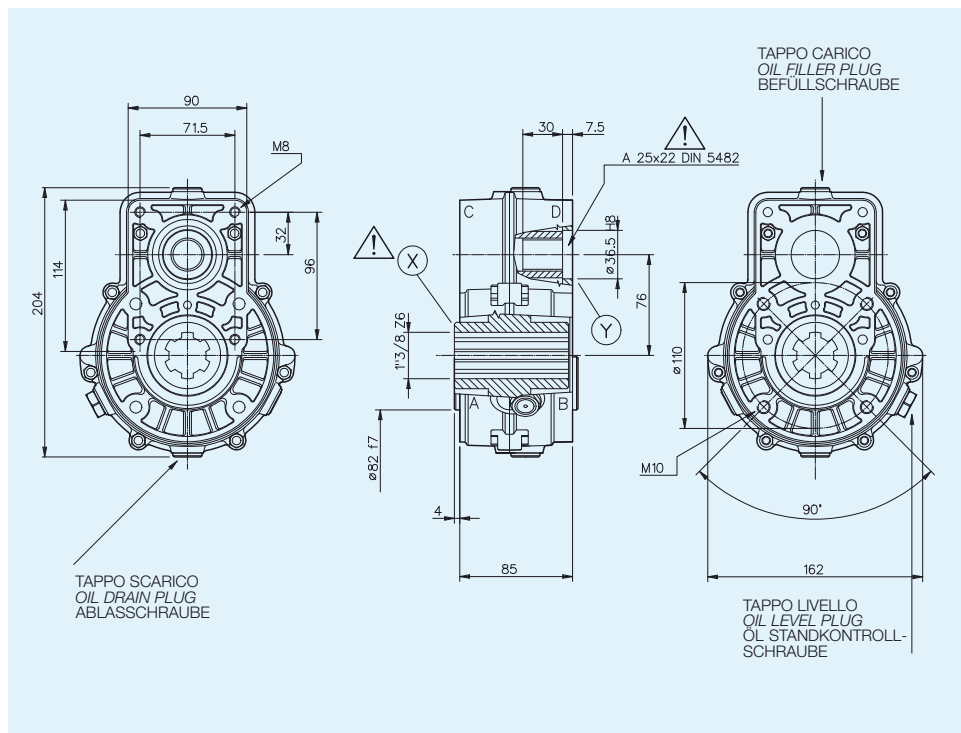

RAPPORTO RATIO VERHÄLTNIS	INGRESSO INPUT EINGANG				USCITA OUTPUT AUSGANG		MONTAGGIO ARRANGEMENT MONTAGE	ENTRATA INPUT EINGANG	CODICE CODE BESTELLNUMMER	
	min ⁻¹	POTENZA POWER LEISTUNG		COPPIA TORQUE DREHM.	COPPIA TORQUE DREHM.	min ⁻¹				
		CV	kW	N-m	N-m					
1:3,35	540	14	10.3	186	55	1809		X	6072.301.033	
1:3,8	540	12	8.8	159	42	2052		X	6072.301.038	
PESO INDICATIVO APPROXIMATE WEIGHT GEWICHT CA.	OLIO CONSIGLIATO RECOMMENDED OIL EMPFOHLENES ÖL	MATERIALI MATERIALS WERKSTOFF			CUSCINETTI BEARINGS NADELLAGER					
		SAE 90 Kg.	SCATOLA CASE GEHAUSE	ALBERI SHAFTS WELLEN	INGRANAGGI GEARS VERZÄHNUNG	A	B	C	D	E
Kg.										
5	0,14	GDAISI 12	20MnCr5	20MnCr5	6010	6010	6007	6007		

**SCATOLE PER POMPE OLEODINAMICHE
GEARBOX FOR HYDRAULIC GEAR PUMPS
GETRIEBE FÜR ÖLKRAFTZAHNRADERPUMPEN**

MP10

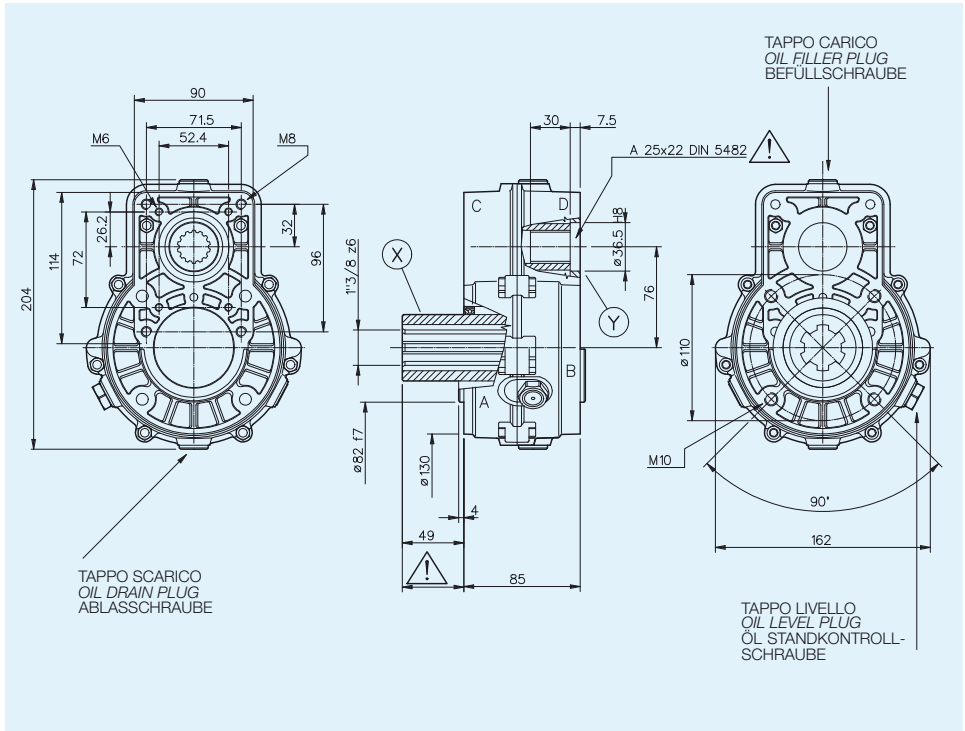

RAPPORTO RATIO VERHÄLTNIS	INGRESSO INPUT EINGANG			USCITA OUTPUT AUSGANG		MONTAGGIO ARRANGEMENT MONTAGE	ENTRATA INPUT EINGANG	CODICE CODE BESTELLNUMMER
	min ⁻¹	POTENZA POWER LEISTUNG CV	kW	COPPIA TORQUE DREHM. N-m	COPPIA TORQUE DREHM. N-m			
1:1,5	540	14	10.3	186	124	810	X	6072.303.015
1:2	540	14	10.3	186	93	1080	X	6072.303.020
1:3,35	540	14	10.3	186	55	1809	X	6072.303.033
1:3,8	540	12	8.8	159	42	2052	X	6072.303.038

PESO INDICATIVO APPROXIMATE WEIGHT GEWICHT CA.	OLIO CONSIGLIATO RECOMMENDED OIL EMPFOHLENES ÖL	MATERIALI MATERIALS WERKSTOFF			CUSCINETTI BEARINGS NADELLAGER					
		SCATOLA CASE GEHAUSE	ALBERI SHAFTS WELLEN	INGRANAGGI GEARS VERZÄHNUNG	A	B	C	D	E	
Kg.	SAE 90 Kg.									
5	0,14	GDAISI 12	20MnCr5	20MnCr5	6010	6010	6007	6007		

**SCATOLE PER POMPE OLEODINAMICHE
GEARBOX FOR HYDRAULIC GEAR PUMPS
GETRIEBE FÜR ÖLKRAFTZAHNRADERPUMPEN**

MP10

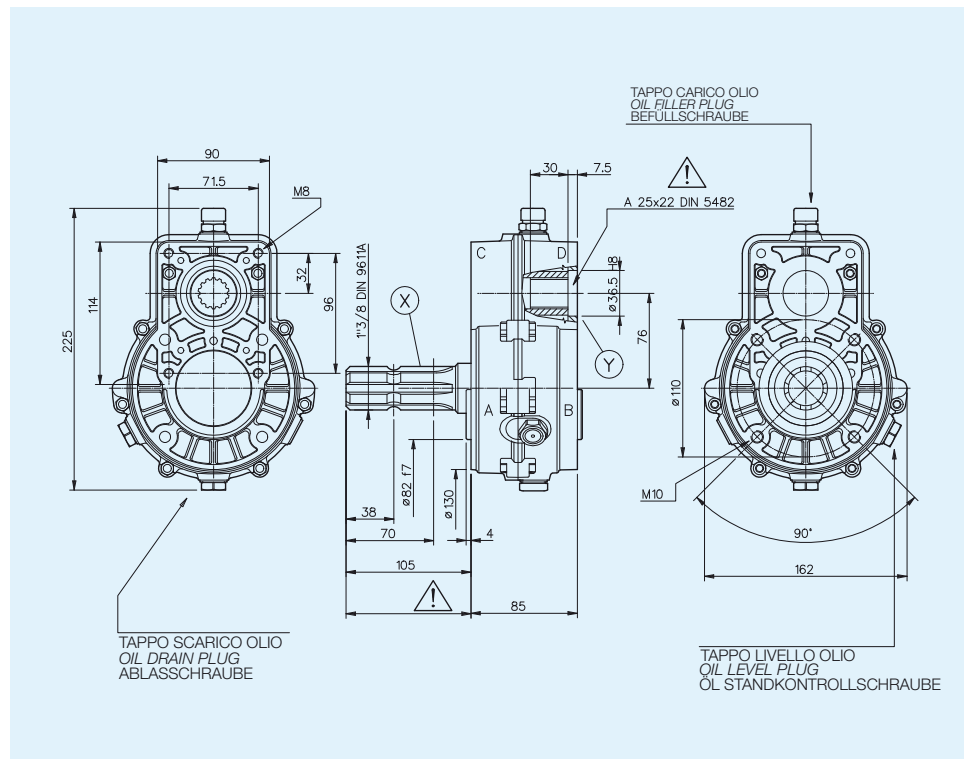

RAPPORTO RATIO VERHÄLTNIS	ENTRATA INPUT EINGANG		USCITA OUTPUT AUSGANG			MONTAGGIO ARRANGEMENT MONTAGE	ENTRATA INPUT EINGANG	CODICE CODE BESTELLNUMMER
	giri/min r.p.m. U/min. min ⁻¹	POTENZA POWER LEISTUNG CV kW	COPPIA TORQUE DREHEM N-m	COPPIA TORQUE DREHEM N-m	giri/min r.p.m. U/min. min ⁻¹			
1:1.5	540	14 10.3	186	124	810		X	6072.001.015S
1:2	540	14 10.3	186	93	1080		X	6072.001.020S
1:3.35	540	14 10.3	186	55	1809		X	6072.001.033S
1:3.8	540	12 8.8	159	42	2052		X	6072.001.038S

PESO INDICATIVO APPROXIMATE WEIGHT GEWICHT CA.	OLIO CONSIGLIATO RECOMMENDED OIL EMPFOHLENES ÖL	MATERIALI MATERIALS WERKSTOFF			CUSCINETTI BEARINGS NADELLAGER					
		SCATOLA CASE GEHAUSE	ALBERI SHAFTS WELLEN	INGRANAGGI GEARS VERZÄHNUNG	A	B	C	D	E	
Kg										
5	SAE 90 Kg 0.14	GD Al Si 12	20MnCr5	20MnCr5	6010	6010	6007	6007		

**SCATOLE PER POMPE OLEODINAMICHE
GEARBOX FOR HYDRAULIC GEAR PUMPS
GETRIEBE FÜR ÖLKRAFTZAHNRADERPUMPEN**

MP10

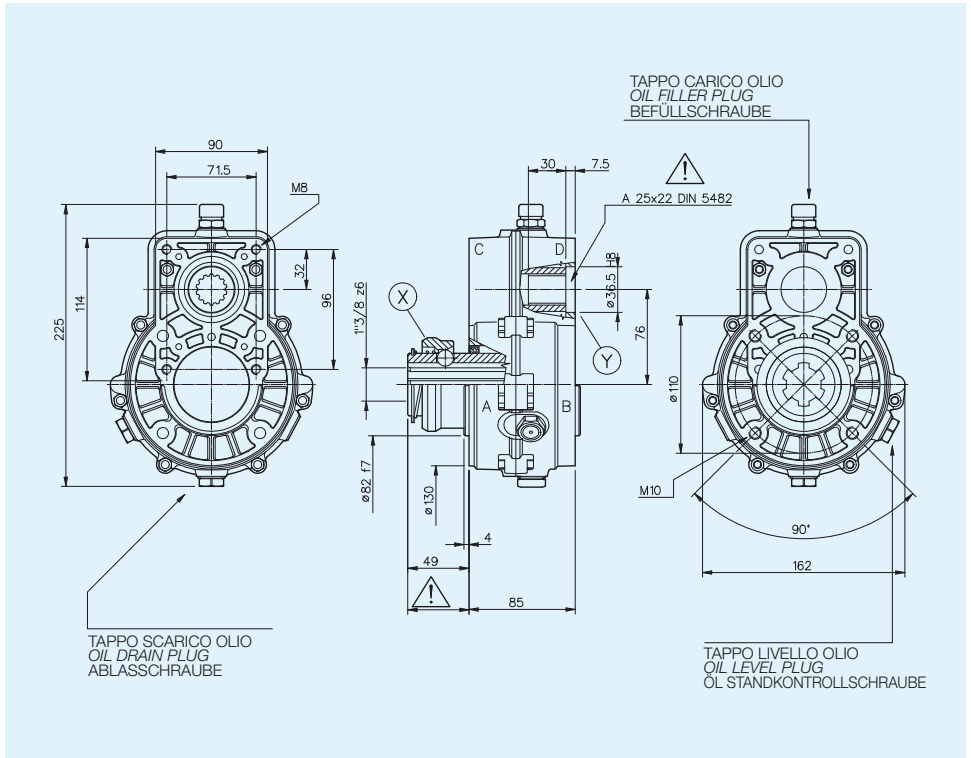

RAPPORTO RATIO VERHÄLTNIS	ENTRATA INPUT EINGANG		USCITA OUTPUT AUSGANG		MONTAGGIO ARRANGEMENT MONTAGE	ENTRATA INPUT EINGANG	CODICE CODE BESTELLNUMMER
	giri/min r.p.m. U/min. min ⁻¹	POTENZA POWER LEISTUNG CV kW	COPPIA TORQUE DREHEM N-m	COPPIA TORQUE DREHEM N-m			
1:2	540	14 10.3	186	93		X	6072.002.020S
1:3.35	540	14 10.3	186	55		X	6072.002.033S
1:3.8	540	12 8.8	159	42		X	6072.002.038S

PESO INDICATIVO APPROXIMATE WEIGHT GEWICHT CA.	OLIO CONSIGLIATO RECOMMENDED OIL EMPFOHLENES ÖL	MATERIALI MATERIALS WERKSTOFF			CUSCINETTI BEARINGS NADELLAGER				
		SCATOLA CASE GEHAUSE	ALBERI SHAFTS WELLEN	INGRANAGGI GEARS VERZÄHNUNG	A	B	C	D	E
Kg									
5	SAE 90 Kg 0.14	GD Al Si 12	20MnCr5	20MnCr5	6010	6010	6007	6007	

**SCATOLE PER POMPE OLEODINAMICHE
GEARBOX FOR HYDRAULIC GEAR PUMPS
GETRIEBE FÜR ÖLKRAFTZAHNRADERPUMPEN**

MP10

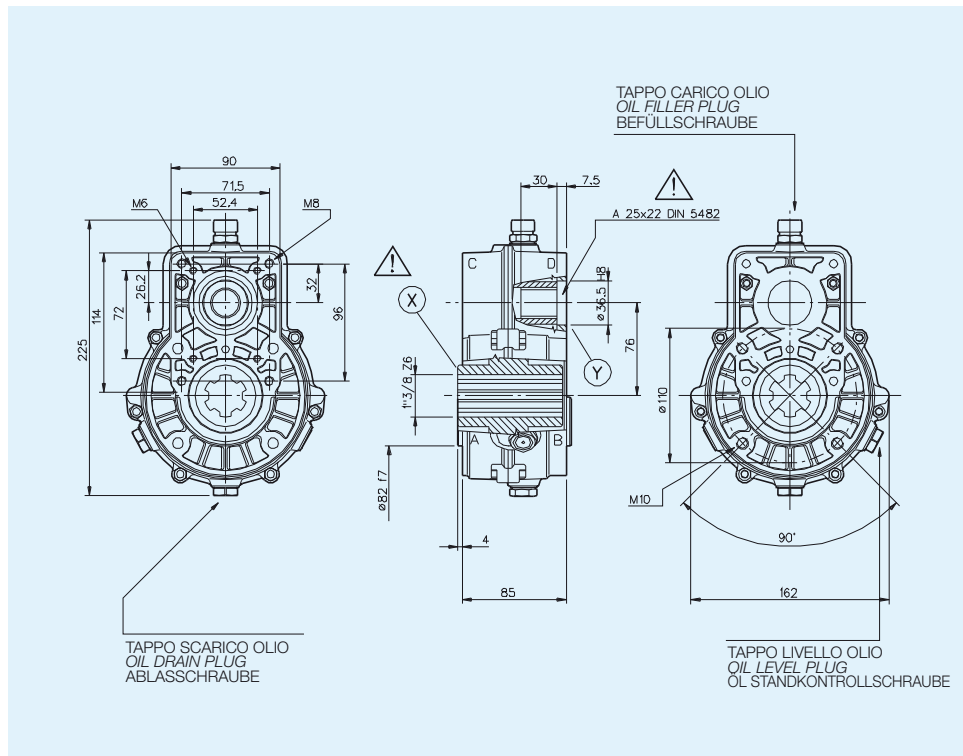

RAPPORTO RATIO VERHÄLTNIS	ENTRATA INPUT EINGANG		USCITA OUTPUT AUSGANG		MONTAGGIO ARRANGEMENT MONTAGE	ENTRATA INPUT EINGANG	CODICE CODE BESTELLNUMMER
	giri/min r.p.m. U/min. min ⁻¹	POTENZA POWER LEISTUNG CV kW	COPPIA TORQUE DREHEM N-m	COPPIA TORQUE DREHEM N-m			
1:3.35	540	14 10.3	186	55		X	6072.301.033S
1:3.8	540	12 8.8	159	42		X	6072.301.038S

PESO INDICATIVO APPROXIMATE WEIGHT GEWICHT CA. Kg	OLIO CONSIGLIATO RECOMMENDED OIL EMPFOHLENES ÖL	MATERIALI MATERIALS WERKSTOFF			CUSCINETTI BEARINGS NADELLAGER				
		SCATOLA CASE GEHAUSE	ALBERI SHAFTS WELLEN	INGRANAGGI GEARS VERZÄHNUNG	A	B	C	D	E
5	SAE 90 Kg 0.14	GD Al Si 12	20MnCr5	20MnCr5	6010	6010	6007	6007	

**SCATOLE PER POMPE OLEODINAMICHE
GEARBOX FOR HYDRAULIC GEAR PUMPS
GETRIEBE FÜR ÖLKRAFTZAHNRADERPUMPEN**

MP10

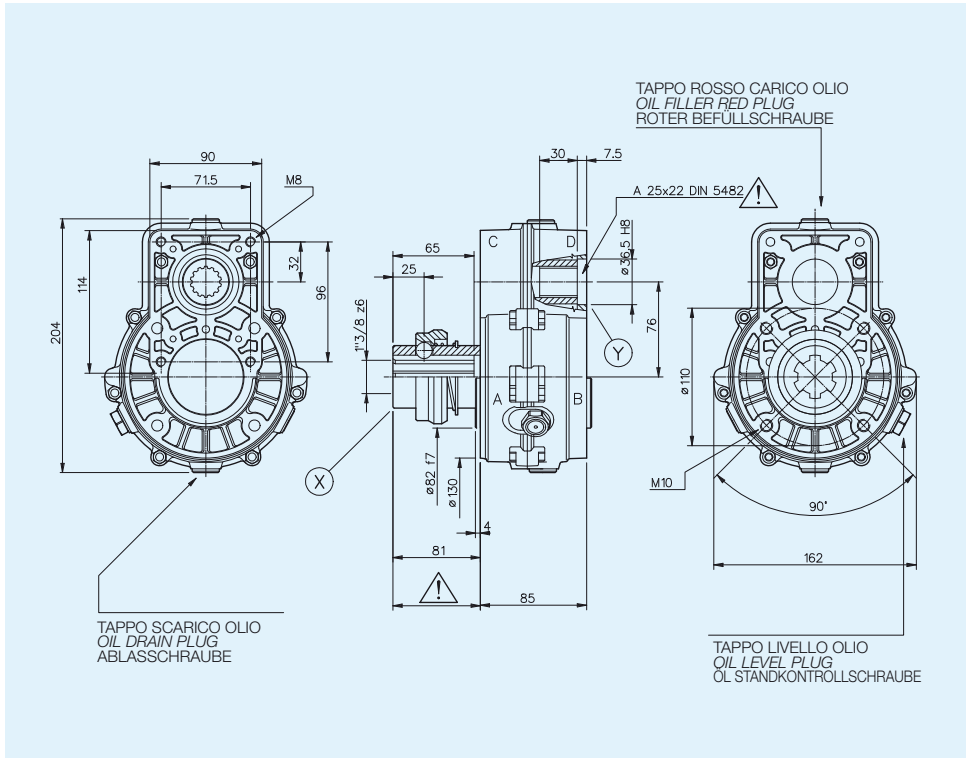

RAPPORTO RATIO VERHÄLTNIS	ENTRATA INPUT EINGANG		USCITA OUTPUT AUSGANG		MONTAGGIO ARRANGEMENT MONTAGE	ENTRATA INPUT EINGANG	CODICE CODE BESTELLNUMMER
	giri/min r.p.m. U/min. min ⁻¹	POTENZA POWER LEISTUNG CV kW	COPPIA TORQUE DREHEM N·m	COPPIA TORQUE DREHEM N·m			
1:3.35	540	14 10.3	186	55	1809	X	6072.302.033
1:3.8	540	12 8.8	159	42	2052	X	6072.302.038

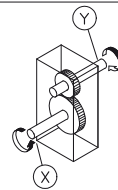

PESO INDICATIVO APPROXIMATE WEIGHT GEWICHT CA.	OLIO CONSIGLIATO RECOMMENDED OIL EMPFOHLENES ÖL	MATERIALI MATERIALS WERKSTOFF			CUSCINETTI BEARINGS NADELLAGER					
		SCATOLA CASE GEHAUSE	ALBERI SHAFTS WELLEN	INGRANAGGI GEARS VERZÄHNUNG	A	B	C	D	E	
Kg										
5	SAE 90 Kg 0.14	GD Al Si 12	20MnCr5	20MnCr5	6010	6010	6007	6007		

SCATOLE PER POMPE OLEODINAMICHE GEARBOX FOR HYDRAULIC GEAR PUMPS GETRIEBE FÜR ÖLKRAFTZAHNRADERPUMPEN

MP10

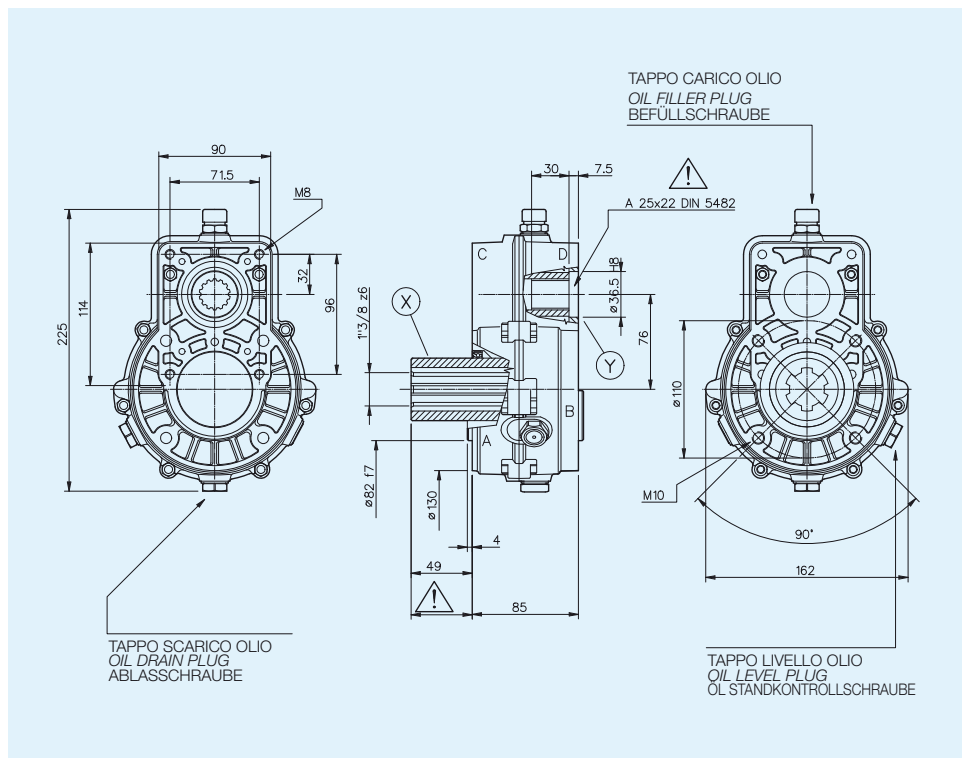

RAPPORTO RATIO VERHÄLTNIS	ENTRATA INPUT EINGANG		USCITA OUTPUT AUSGANG		MONTAGGIO ARRANGEMENT MONTAGE	ENTRATA INPUT EINGANG	CODICE CODE BESTELLNUMMER
	giri/min r.p.m. U/min. min ⁻¹	POTENZA POWER LEISTUNG CV kW	COPPIA TORQUE DREHEM N·m	COPPIA TORQUE DREHEM N·m			
1:3.35	540	14 10.3	186	55		X	6072.303.033S
1:3.8	540	12 8.8	159	42		X	6072.303.038S

PESO INDICATIVO APPROXIMATE WEIGHT GEWICHT CA.	OLIO CONSIGLIATO RECOMMENDED OIL EMPFOHLENES ÖL	MATERIALI MATERIALS WERKSTOFF			CUSCINETTI BEARINGS NADELLAGER					
		SCATOLA CASE GEHAUSE	ALBERI SHAFTS WELLEN	INGRANAGGI GEARS VERZÄHNUNG	A	B	C	D	E	
Kg										
5	SAE 90 Kg 0.14	GD Al Si 12	20MnCr5	20MnCr5	6010	6010	6007	6007		

**SCATOLE PER POMPE OLEODINAMICHE
GEARBOX FOR HYDRAULIC GEAR PUMPS
GETRIEBE FÜR ÖLKRAFTZAHNRADERPUMPEN**

MP10

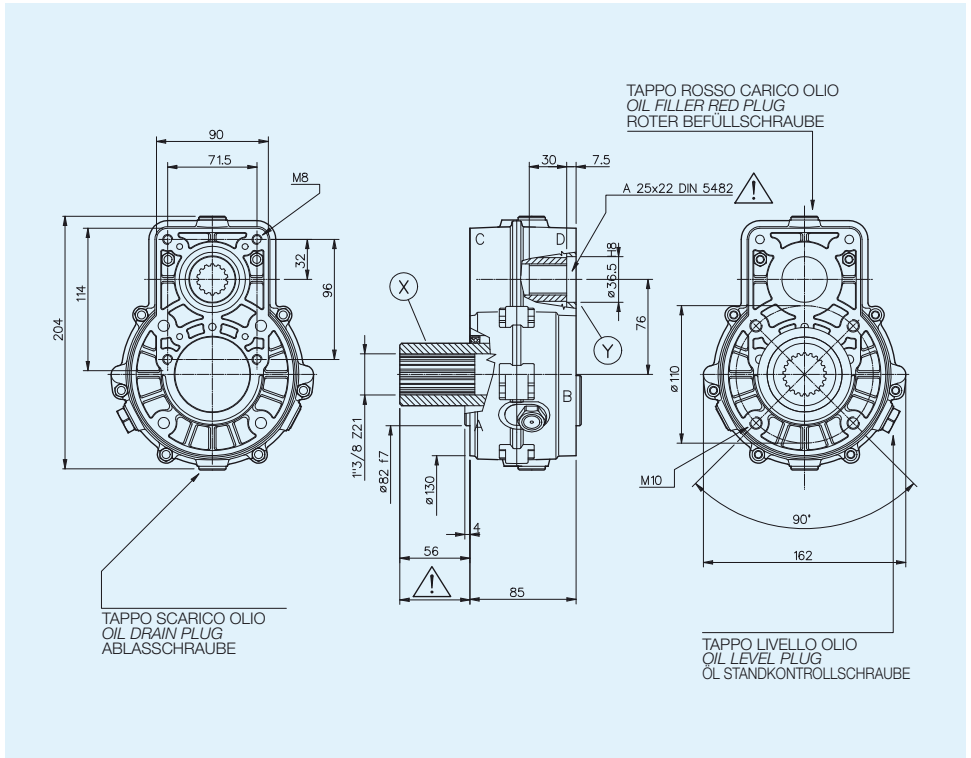

RAPPORTO RATIO VERHÄLTNIS	ENTRATA INPUT EINGANG		USCITA OUTPUT AUSGANG		MONTAGGIO ARRANGEMENT MONTAGE	ENTRATA INPUT EINGANG	CODICE CODE BESTELLNUMMER
	giri/min r.p.m. U/min. min ⁻¹	POTENZA POWER LEISTUNG CV kW	COPPIA TORQUE DREHEM N·m	COPPIA TORQUE DREHEM N·m			
1:2	540	14 10.3	186	93	1080	X	6072.312.020

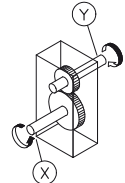

PESO INDICATIVO APPROXIMATE WEIGHT GEWICHT CA.	OLIO CONSIGLIATO RECOMMENDED OIL EMPFOHLENES ÖL	MATERIALI MATERIALS WERKSTOFF			CUSCINETTI BEARINGS NADELLAGER				
		SCATOLA CASE GEHAUSE	ALBERI SHAFTS WELLEN	INGRANAGGI GEARS VERZÄHNUNG	A	B	C	D	E
Kg									
5	SAE 90 Kg 0.14	GD Al Si 12	20MnCr5	20MnCr5	6010	6010	6007	6007	

**SCATOLE PER POMPE OLEODINAMICHE
GEARBOX FOR HYDRAULIC GEAR PUMPS
GETRIEBE FÜR ÖLKRAFTZAHNRADERPUMPEN**

MP21

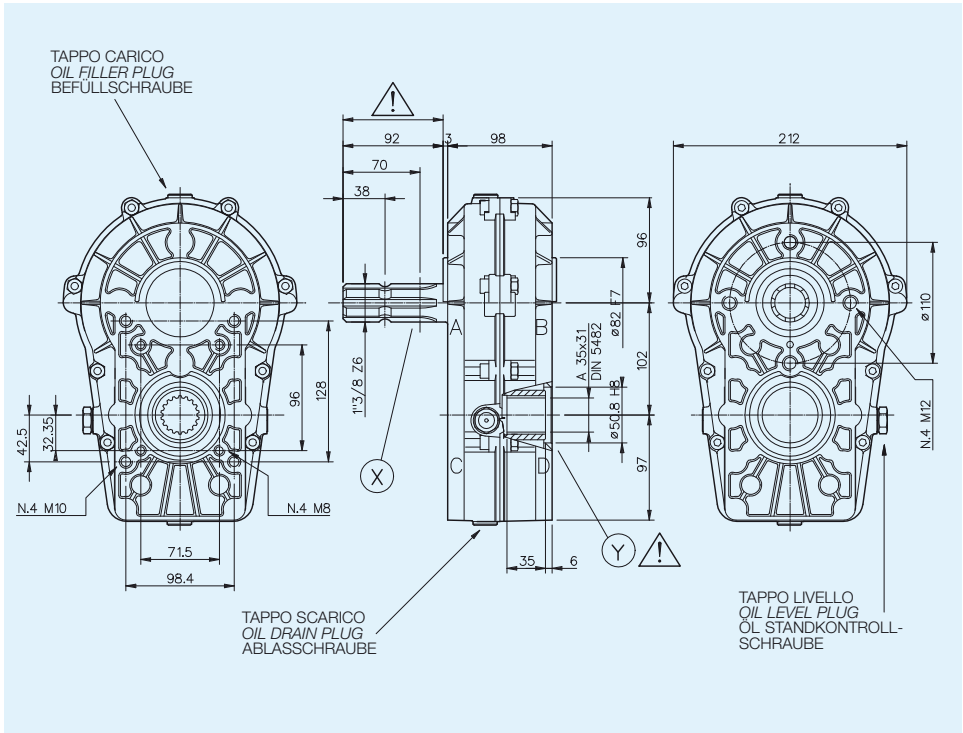

RAPPORTO RATIO VERHÄLTNIS	INGRESSO INPUT EINGANG				USCITA OUTPUT AUSGANG		MONTAGGIO ARRANGEMENT MONTAGE	ENTRATA INPUT EINGANG	CODICE CODE BESTELLNUMMER
	min ⁻¹	POTENZA POWER LEISTUNG CV	POTENZA POWER LEISTUNG kW	COPPIA TORQUE DREHM. N-m	COPPIA TORQUE DREHM. N-m	min ⁻¹			
1:1,5	540	37	27.2	495	330	810		X	6073.001.015
1:2	540	32	23.5	425	217	1080		X	6073.001.020
1:3	540	37	27.2	495	165	1620		X	6073.001.030
1:3,35	540	35	25.7	460	135	1809		X	6073.001.033
1:3,8	540	31	22.8	404	108	2057		X	6073.001.038

PESO INDICATIVO APPROXIMATE WEIGHT GEWICHT CA.	OLIO CONSIGLIATO RECOMMENDED OIL EMPFOHLENES ÖL	MATERIALI MATERIALS WERKSTOFF			CUSCINETTI BEARINGS NADELLAGER				
		SCATOLA CASE GEHAUSE	ALBERI SHAFTS WELLEN	INGRANAGGI GEARS VERZÄHNUNG	A	B	C	D	E
Kg.	SAE 90 Kg.	GDAISI 12	20MnCr5	20MnCr5	6010	6010	6009	6009	

**SCATOLE PER POMPE OLEODINAMICHE
GEARBOX FOR HYDRAULIC GEAR PUMPS
GETRIEBE FÜR ÖLKRAFTZAHNRADERPUMPEN**

MP21

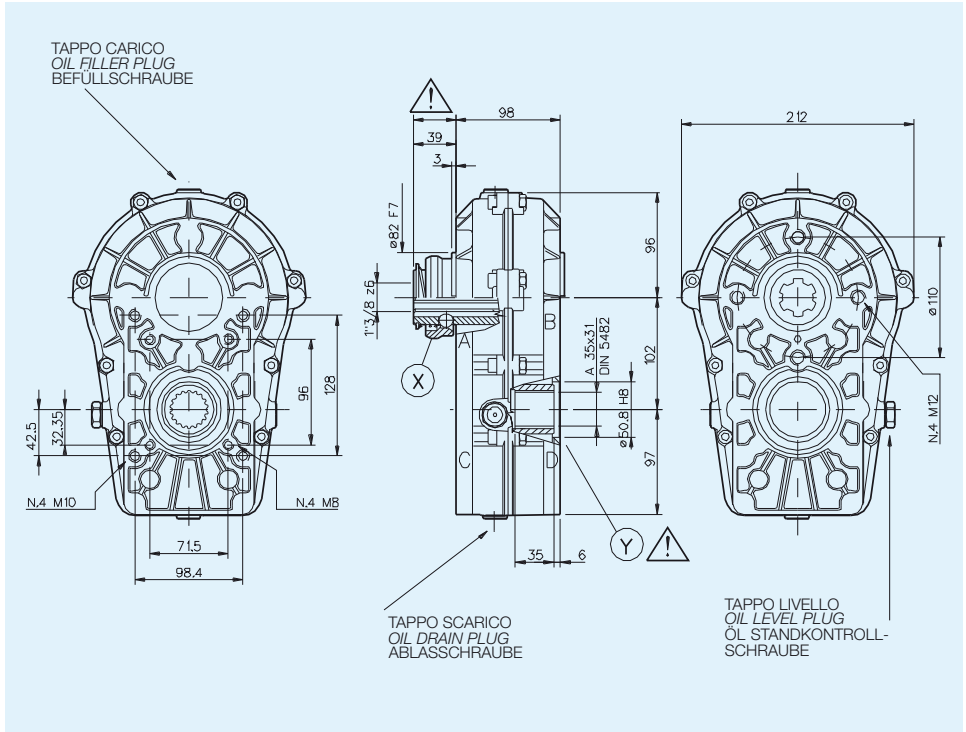

RAPPORTO RATIO VERHÄLTNIS	INGRESSO INPUT EINGANG			USCITA OUTPUT AUSGANG		MONTAGGIO ARRANGEMENT MONTAGE	ENTRATA INPUT EINGANG	CODICE CODE BESTELLNUMMER
	min ⁻¹	POTENZA POWER LEISTUNG CV	kW	COPPIA TORQUE DREHM. N-m	COPPIA TORQUE DREHM. N-m			
1:1,5	540	37	27.2	495	330	810	X	6073.002.015
1:3	540	14	10	182	60	1620	X	6073.002.030
1:3,35	540	35	25.7	460	135	1809	X	6073.002.033
1:3,8	540	31	22.8	404	108	2057	X	6073.002.038

PESO INDICATIVO APPROXIMATE WEIGHT GEWICHT CA. Kg.	OLIO CONSIGLIATO RECOMMENDED OIL EMPFOHLENES ÖL SAE 90 Kg.	MATERIALI MATERIALS WERKSTOFF			CUSCINETTI BEARINGS NADELLAGER				
		SCATOLA CASE GEHAUSE	ALBERI SHAFTS WELLEN	INGRANAGGI GEARS VERZÄHNUNG	A	B	C	D	E
9	0,46	GDAISI 12	20MnCr5	20MnCr5	6010	6010	6009	6009	

SCATOLE PER POMPE OLEODINAMICHE GEARBOX FOR HYDRAULIC GEAR PUMPS GETRIEBE FÜR ÖLKRAFTZAHNRADERPUMPEN

MP21

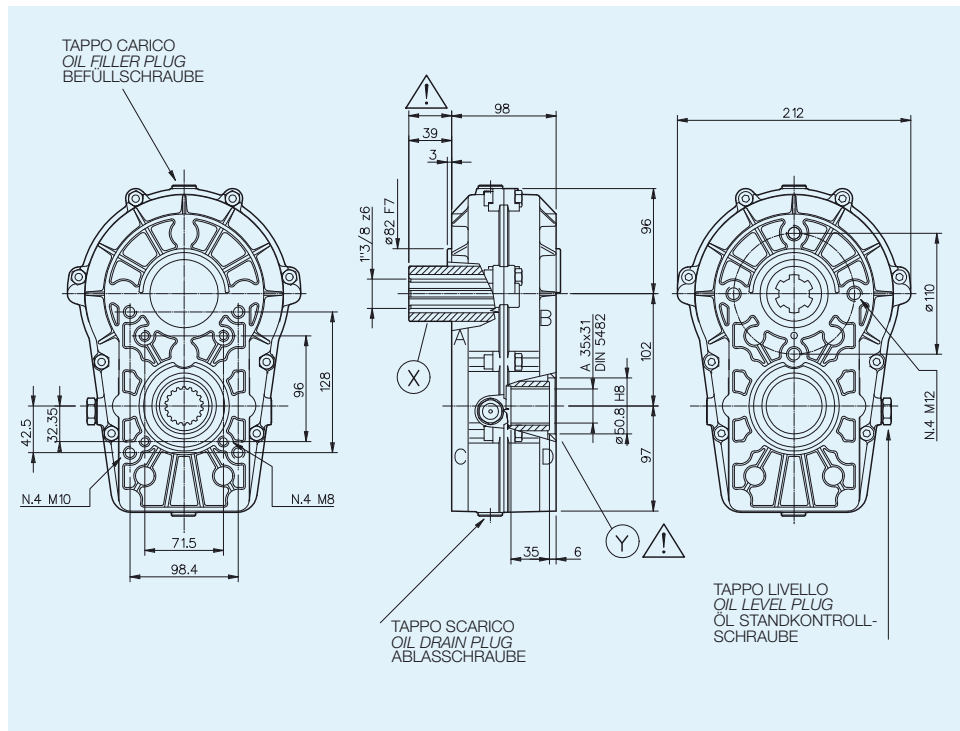

RAPPORTO RATIO VERHÄLTNIS	INGRESSO INPUT EINGANG				USCITA OUTPUT AUSGANG		MONTAGGIO ARRANGEMENT MONTAGE	ENTRATA INPUT EINGANG	CODICE CODE BESTELLNUMMER
	min ⁻¹	POTENZA POWER LEISTUNG		COPPIA TORQUE DREHM.	COPPIA TORQUE DREHM.	min ⁻¹			
		CV	kW	N-m	N-m				
1:2	540	32	23.5	425	217	1080		X	6073.300.020
1:3,35	540	35	25.7	460	135	1809		X	6073.300.033
1:3,8	540	31	22.8	404	108	2057		X	6073.300.038

PESO INDICATIVO APPROXIMATE WEIGHT GEWICHT CA.	OLIO CONSIGLIATO RECOMMENDED OIL EMPFOHLENES ÖL	MATERIALI MATERIALS WERKSTOFF			CUSCINETTI BEARINGS NADELLAGER				
		SCATOLA CASE GEHAUSE	ALBERI SHAFTS WELLEN	INGRANAGGI GEARS VERZÄHNUNG	A	B	C	D	E
Kg.	SAE 90 Kg.								
9	0,46	GDAISI 12	20MnCr5	20MnCr5	6010	6010	6009	6009	

SCATOLE PER POMPE OLEODINAMICHE GEARBOX FOR HYDRAULIC GEAR PUMPS GETRIEBE FÜR ÖLKRAFTZAHNRADERPUMPEN

MP21

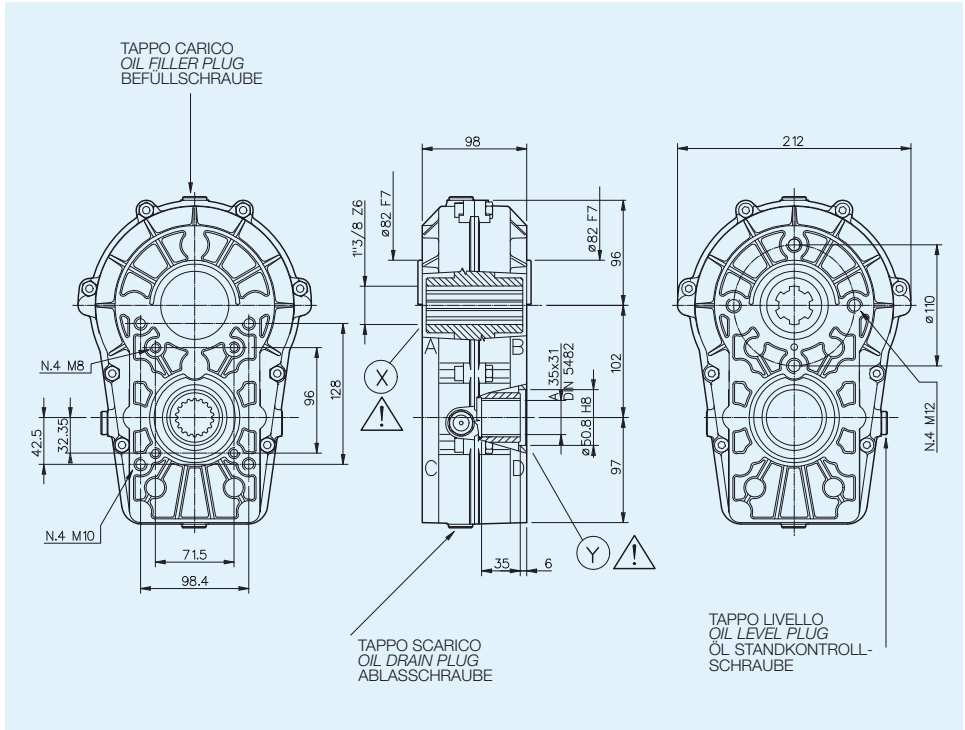

RAPPORTO RATIO VERHÄLTNIS	INGRESSO INPUT EINGANG			USCITA OUTPUT AUSGANG		MONTAGGIO ARRANGEMENT MONTAGE	ENTRATA INPUT EINGANG	CODICE CODE BESTELLNUMMER
	min ⁻¹	POTENZA POWER LEISTUNG CV kW	COPPIA TORQUE DREHM. N-m	COPPIA TORQUE DREHM. N-m	min ⁻¹			
1:3,35	540	35 25.7	460	135	1809		X	6073.308.033
1:3,8	540	31 22.8	404	108	2057		X	6073.308.038

PESO INDICATIVO APPROXIMATE WEIGHT GEWICHT CA.	OLIO CONSIGLIATO RECOMMENDED OIL EMPFOHLENES ÖL	MATERIALI MATERIALS WERKSTOFF			CUSCINETTI BEARINGS NADELLAGER				
		SCATOLA CASE GEHAUSE	ALBERI SHAFTS WELLEN	INGRANAGGI GEARS VERZÄHNUNG	A	B	C	D	E
Kg.	SAE 90 Kg.								
9	0,46	GDAISI 12	20MnCr5	20MnCr5	6010	6010	6009	6009	

**SCATOLE PER POMPE OLEODINAMICHE
GEARBOX FOR HYDRAULIC GEAR PUMPS
GETRIEBE FÜR ÖLKRAFTZAHNRADERPUMPEN**

MP21

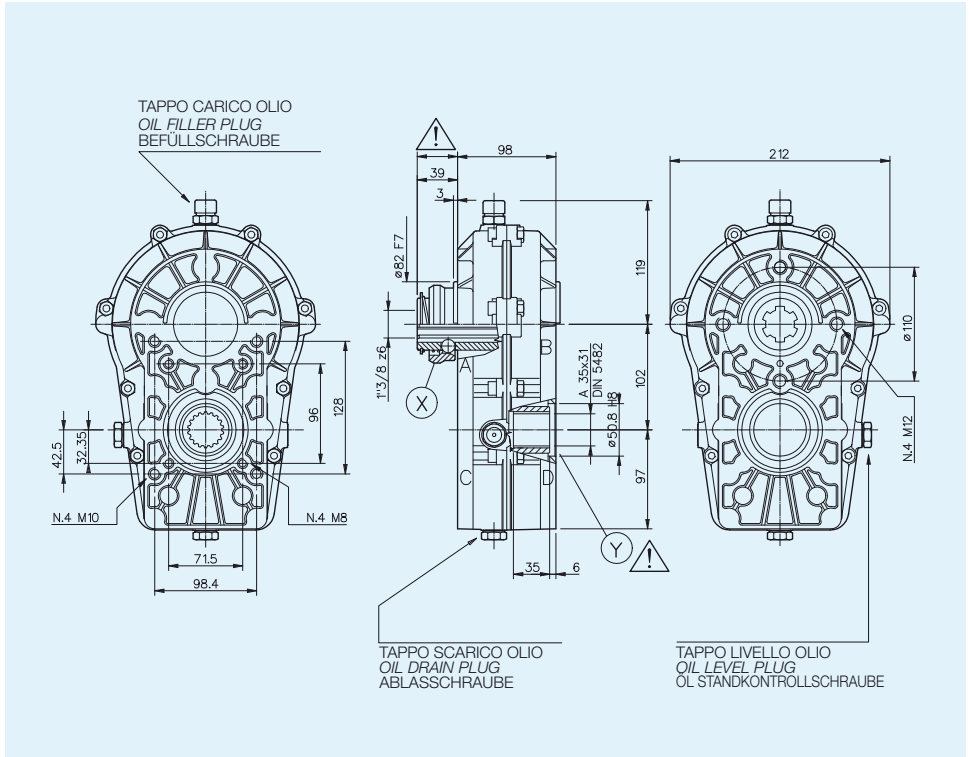

RAPPORTO RATIO VERHALTNIS	ENTRATA INPUT EINGANG		USCITA OUTPUT AUSGANG		MONTAGGIO ARRANGEMENT MONTAGE	ENTRATA INPUT EINGANG	CODICE CODE BESTELLNUMMER
	giri/min r.p.m. U/min. min ⁻¹	POTENZA POWER LEISTUNG CV kW	COPPIA TORQUE DREHEM N·m	COPPIA TORQUE DREHEM N·m			
1:2	540	32 23.5	425	217		X	6073.002.020S
1:3	540	37 27.2	495	165		X	6073.002.030S
1:3.35	540	35 25.7	460	135		X	6073.002.033S
1:3.8	540	31 22.8	404	108		X	6073.002.038S

PESO INDICATIVO APPROXIMATE WEIGHT GEWICHT CA.	OLIO CONSIGLIATO RECOMMENDED OIL EMPFOHLENES ÖL	MATERIALI MATERIALS WERKSTOFF			CUSCINETTI BEARINGS NADELLAGER					
		SCATOLA CASE GEHAUSE	ALBERI SHAFTS WELLEN	INGRANAGGI GEARS VERZÄHNUNG	A	B	C	D	E	
Kg										
9	SAE 90 Kg 0.46	GD Al Si 12	20MnCr5	20MnCr5	6010	6010	6009	6009		

**SCATOLE PER POMPE OLEODINAMICHE
GEARBOX FOR HYDRAULIC GEAR PUMPS
GETRIEBE FÜR ÖLKRAFTZAHNRADERPUMPEN**

MP21

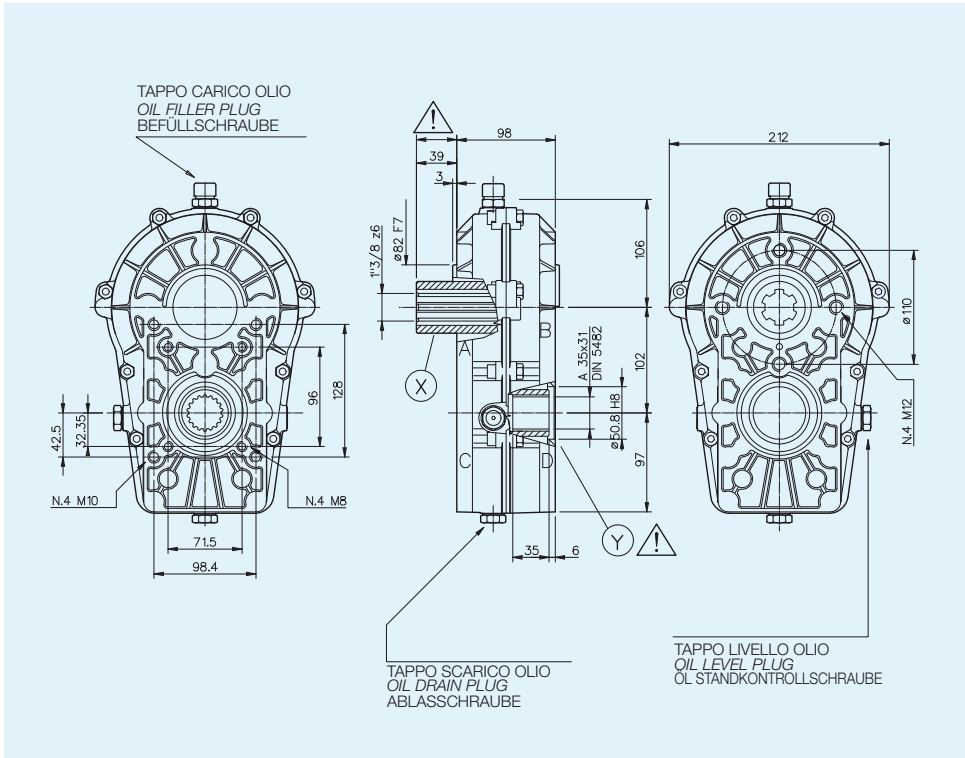

RAPPORTO RATIO VERHALTNIS	ENTRATA INPUT EINGANG		USCITA OUTPUT AUSGANG			MONTAGGIO ARRANGEMENT MONTAGE	ENTRATA INPUT EINGANG	CODICE CODE BESTELLNUMMER
	giri/min r.p.m. U/min. min ⁻¹	POTENZA POWER LEISTUNG CV kW	COPPIA TORQUE DREHEM N·m	COPPIA TORQUE DREHEM N·m	giri/min r.p.m. U/min. min ⁻¹			
1:2	540	32 23.5	425	217	1080		X	6073.300.020S
1:3.35	540	35 25.7	460	135	1809		X	6073.300.033S
1:3.8	540	31 22.8	404	108	2057		X	6073.300.038S

PESO INDICATIVO APPROXIMATE WEIGHT GEWICHT CA.	OLIO CONSIGLIATO RECOMMENDED OIL EMPFOHLENES ÖL	MATERIALI MATERIALS WERKSTOFF			CUSCINETTI BEARINGS NADELLAGER				
		SCATOLA CASE GEHAUSE	ALBERI SHAFTS WELLEN	INGRANAGGI GEARS VERZÄHNUNG	A	B	C	D	E
Kg									
9	SAE 90 Kg 0.46	GD Al Si 12	20MnCr5	20MnCr5	6010	6010	6009	6009	

**SCATOLE PER POMPE OLEODINAMICHE
GEARBOX FOR HYDRAULIC GEAR PUMPS
GETRIEBE FÜR ÖLKRAFTZAHNRADERPUMPEN**

MP21

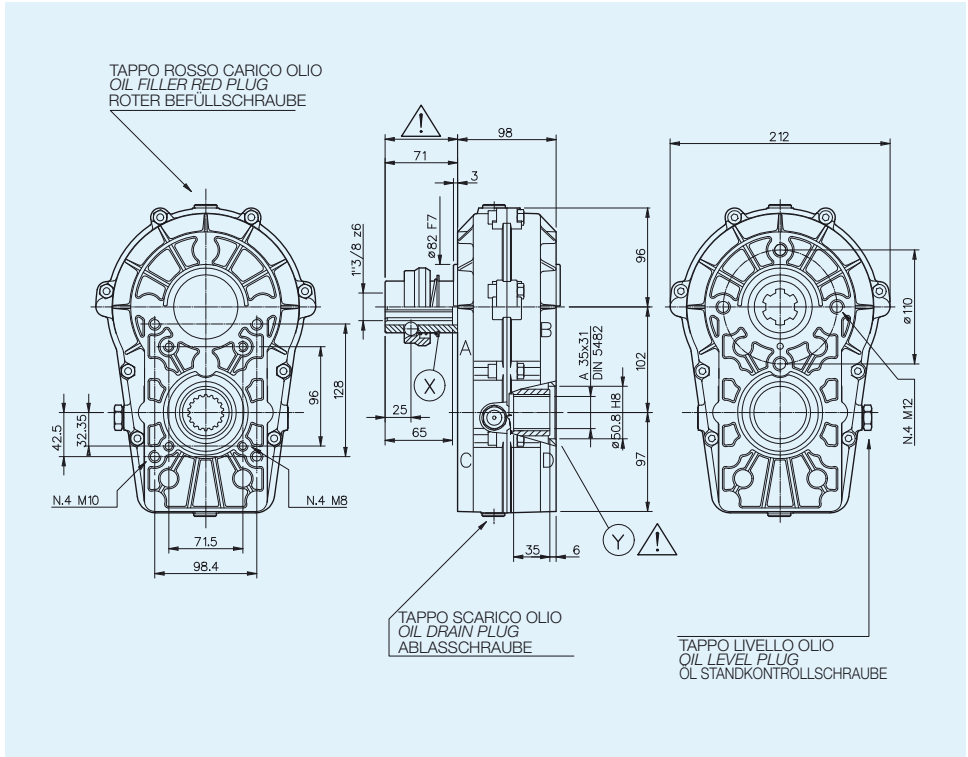

RAPPORTO RATIO VERHÄLTNIS	ENTRATA INPUT EINGANG		USCITA OUTPUT AUSGANG		MONTAGGIO ARRANGEMENT MONTAGE	ENTRATA INPUT EINGANG	CODICE CODE BESTELLNUMMER
	giri/min r.p.m. U/min. min ⁻¹	POTENZA POWER LEISTUNG CV kW	COPPIA TORQUE DREHEM N·m	COPPIA TORQUE DREHEM N·m			
1:3.35	540	35 25.7	460	135		X	6073.303.033
1:3.8	540	31 22.8	404	108		X	6073.303.038

PESO INDICATIVO APPROXIMATE WEIGHT GEWICHT CA.	OLIO CONSIGLIATO RECOMMENDED OIL EMPFOHLENES ÖL	MATERIALI MATERIALS WERKSTOFF			CUSCINETTI BEARINGS NADELLAGER				
		SCATOLA CASE GEHAUSE	ALBERI SHAFTS WELLEN	INGRANAGGI GEARS VERZÄHNUNG	A	B	C	D	E
Kg									
9	SAE 90 Kg 0.46	GD Al Si 12	20MnCr5	20MnCr5	6010	6010	6009	6009	

**SCATOLE PER POMPE OLEODINAMICHE
GEARBOX FOR HYDRAULIC GEAR PUMPS
GETRIEBE FÜR ÖLKRAFTZAHNRADERPUMPEN**

MP21

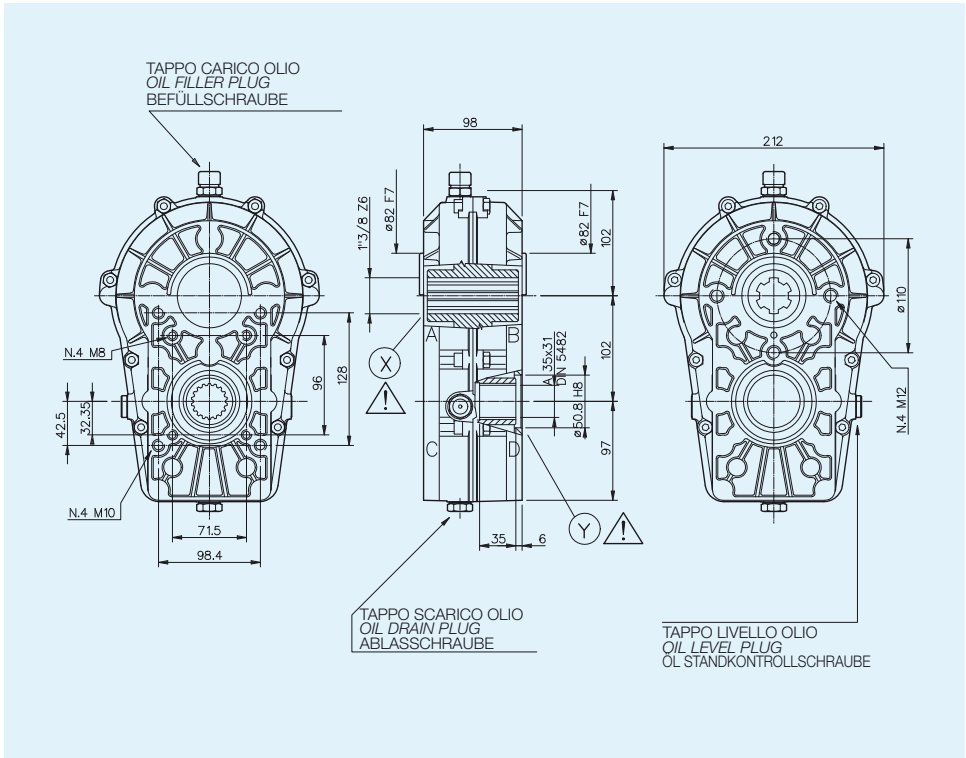

RAPPORTO RATIO VERHALTNIS	ENTRATA INPUT EINGANG		USCITA OUTPUT AUSGANG		MONTAGGIO ARRANGEMENT MONTAGE	ENTRATA INPUT EINGANG	CODICE CODE BESTELLNUMMER
	giri/min r.p.m. U/min. min ⁻¹	POTENZA POWER LEISTUNG CV kW	COPPIA TORQUE DREHEM N·m	COPPIA TORQUE DREHEM N·m			
1:3	540	37 27.2	495	165	1620	X	6073.308.030S
1:3.35	540	35 25.7	460	135	1809	X	6073.308.033S
1:3.8	540	31 22.8	404	108	2057	X	6073.308.038S

PESO INDICATIVO APPROXIMATE WEIGHT GEWICHT CA.	OLIO CONSIGLIATO RECOMMENDED OIL EMPFOHLENES ÖL	MATERIALI MATERIALS WERKSTOFF			CUSCINETTI BEARINGS NADELLAGER				
		SCATOLA CASE GEHAUSE	ALBERI SHAFTS WELLEN	INGRANAGGI GEARS VERZAHNUNG	A	B	C	D	E
Kg									
9	SAE 90 Kg 0.46	GD Al Si 12	20MnCr5	20MnCr5	6010	6010	6009	6009	

**SCATOLE PER POMPE OLEODINAMICHE
GEARBOX FOR HYDRAULIC GEAR PUMPS
GETRIEBE FÜR ÖLKRAFTZAHNRADERPUMPEN**

MP21

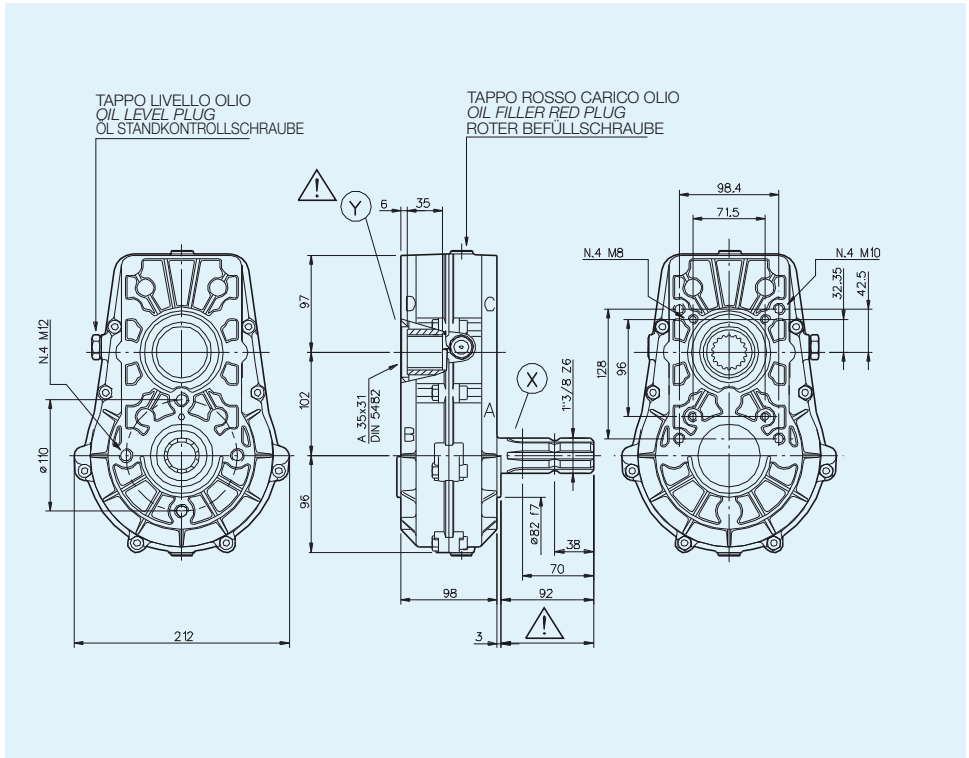

RAPPORTO RATIO VERHALTNIS	ENTRATA INPUT EINGANG		USCITA OUTPUT AUSGANG		MONTAGGIO ARRANGEMENT MONTAGE	ENTRATA INPUT EINGANG	CODICE CODE BESTELLNUMMER
	giri/min r.p.m. U/min. min ⁻¹	POTENZA POWER LEISTUNG CV kW	COPPIA TORQUE DREHEM N·m	COPPIA TORQUE DREHEM N·m			
1:2	540	32 23.5	425	217	1080	X	6073.310.020
1:3.35	540	35 25.7	460	135	1809	X	6073.310.033
1:3.8	540	31 22.8	404	108	2057	X	6073.310.038

PESO INDICATIVO APPROXIMATE WEIGHT GEWICHT CA.	OLIO CONSIGLIATO RECOMMENDED OIL EMPFOHLENES ÖL	MATERIALI MATERIALS WERKSTOFF			CUSCINETTI BEARINGS NADELLAGER				
		SCATOLA CASE GEHAUSE	ALBERI SHAFTS WELLEN	INGRANAGGI GEARS VERZÄHNUNG	A	B	C	D	E
Kg									
9.5	SAE 90 Kg 0.46	GD Al Si 12	20MnCr5	20MnCr5	6010	6010	6009	6009	

**SCATOLE PER POMPE OLEODINAMICHE
GEARBOX FOR HYDRAULIC GEAR PUMPS
GETRIEBE FÜR ÖLKRAFTZAHNRADERPUMPEN**

MP21

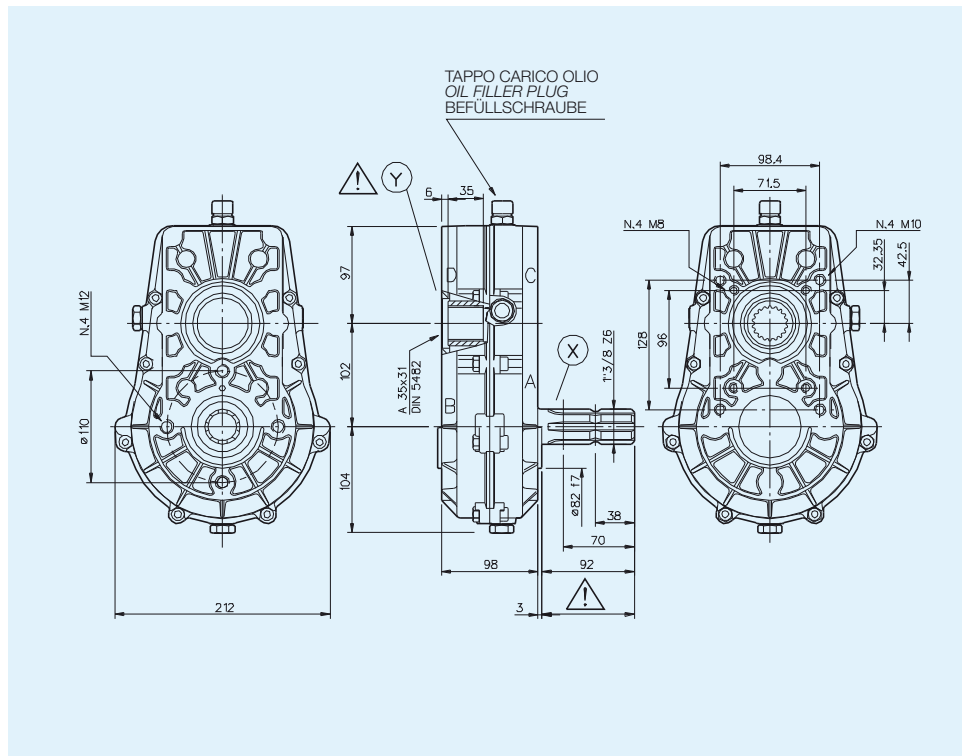

RAPPORTO RATIO VERHALTNIS	ENTRATA INPUT EINGANG		USCITA OUTPUT AUSGANG		MONTAGGIO ARRANGEMENT MONTAGE	ENTRATA INPUT EINGANG	CODICE CODE BESTELLNUMMER
	giri/min r.p.m. U/min. min ⁻¹	POTENZA POWER LEISTUNG CV kW	COPPIA TORQUE DREHEM N-m	COPPIA TORQUE DREHEM N-m			
1:2	540	32 23.5	425	217		X	6073.310.020S
1:3.35	540	35 25.7	460	135		X	6073.310.033S
1:3.8	540	31 22.8	404	108		X	6073.310.038S

PESO INDICATIVO APPROXIMATE WEIGHT GEWICHT CA.	OLIO CONSIGLIATO RECOMMENDED OIL EMPFOHLENES ÖL	MATERIALI MATERIALS WERKSTOFF			CUSCINETTI BEARINGS NADELLAGER				
		SCATOLA CASE GEHAUSE	ALBERI SHAFTS WELLEN	INGRANAGGI GEARS VERZÄHNUNG	A	B	C	D	E
Kg 9	SAE 90 Kg 0.46	GD Al Si 12	20MnCr5	20MnCr5	6010	6010	6009	6009	

**SCATOLE PER POMPE OLEODINAMICHE
GEARBOX FOR HYDRAULIC GEAR PUMPS
GETRIEBE FÜR ÖLKRAFTZAHNRADERPUMPEN**

MP21

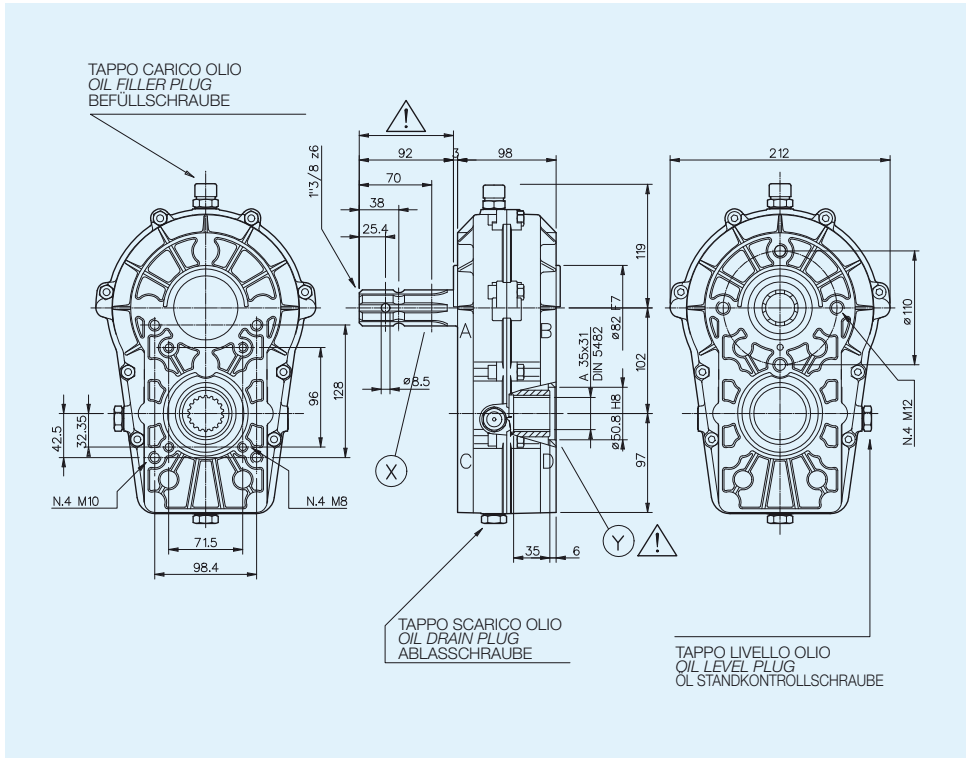

RAPPORTO RATIO VERHÄLTNIS	ENTRATA INPUT EINGANG		USCITA OUTPUT AUSGANG		MONTAGGIO ARRANGEMENT MONTAGE	ENTRATA INPUT EINGANG	CODICE CODE BESTELLNUMMER
	giri/min r.p.m. U/min. min ⁻¹	POTENZA POWER LEISTUNG CV kW	COPPIA TORQUE DREHEM N·m	COPPIA TORQUE DREHEM N·m			
1:3.8	540	31 22.8	404	108	2057	X	6073.314.038

PESO INDICATIVO APPROXIMATE WEIGHT GEWICHT CA.	OLIO CONSIGLIATO RECOMMENDED OIL EMPFOHLENES ÖL	MATERIALI MATERIALS WERKSTOFF			CUSCINETTI BEARINGS NADELLAGER				
		SCATOLA CASE GEHAUSE	ALBERI SHAFTS WELLEN	INGRANAGGI GEARS VERZÄHNUNG	A	B	C	D	E
Kg 9	SAE 90 Kg 0.46	GD Al Si 12	20MnCr5	20MnCr5	6010	6010	6009	6009	

SCATOLE PER POMPE OLEODINAMICHE GEARBOX FOR HYDRAULIC GEAR PUMPS GETRIEBE FÜR ÖLKRAFTZAHNRADERPUMPEN

MP21

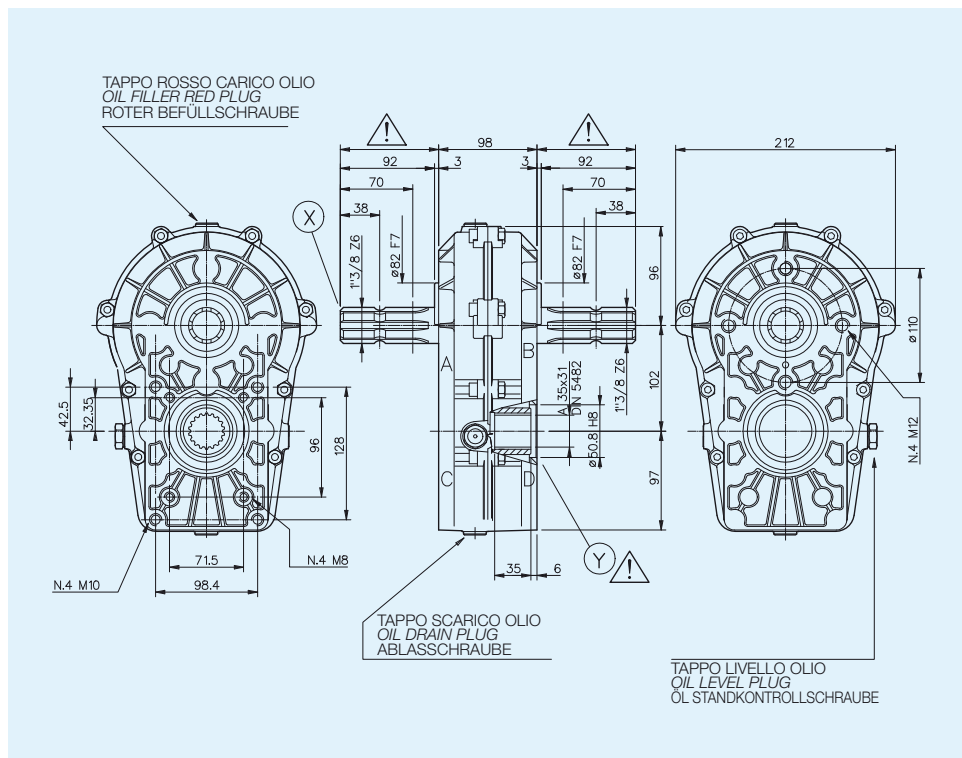

RAPPORTO RATIO VERHALTNIS	ENTRATA INPUT EINGANG		USCITA OUTPUT AUSGANG			MONTAGGIO ARRANGEMENT MONTAGE	ENTRATA INPUT EINGANG	CODICE CODE BESTELLNUMMER
	giri/min r.p.m. U/min. min ⁻¹	POTENZA POWER LEISTUNG CV kW	COPPIA TORQUE DREHEM N·m	COPPIA TORQUE DREHEM N·m	giri/min r.p.m. U/min. min ⁻¹			
1:3.8	540	31 22.8	404	108	2057		X	6073.317.038

PESO INDICATIVO APPROXIMATE WEIGHT GEWICHT CA.	OLIO CONSIGLIATO RECOMMENDED OIL EMPFOHLENES ÖL	MATERIALI MATERIALS WERKSTOFF			CUSCINETTI BEARINGS NADELLAGER				
		SCATOLA CASE GEHAUSE	ALBERI SHAFTS WELLEN	INGRANAGGI GEARS VERZÄHNUNG	A	B	C	D	E
Kg 10,5	SAE 90 Kg 0.46	GD Al Si 12	20MnCr5	20MnCr5	6010	6010	6009	6009	

**SCATOLE PER POMPE OLEODINAMICHE
GEARBOX FOR HYDRAULIC GEAR PUMPS
GETRIEBE FÜR ÖLKRAFTZAHNRADERPUMPEN**

MP21

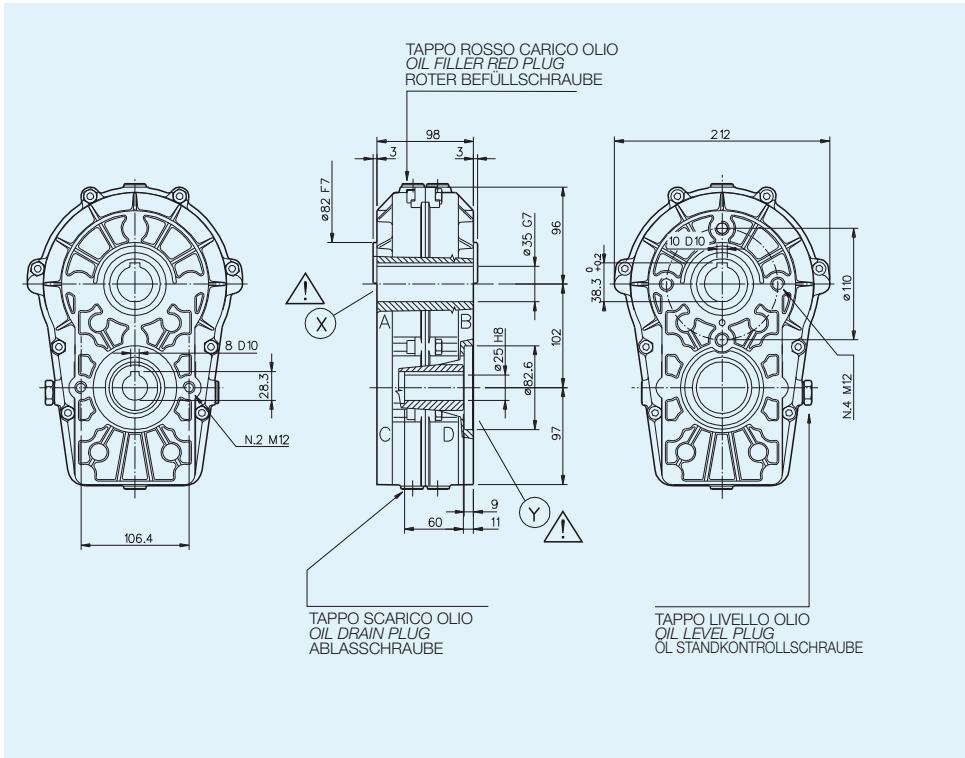

RAPPORTO RATIO VERHALTNIS	ENTRATA INPUT EINGANG		USCITA OUTPUT AUSGANG			MONTAGGIO ARRANGEMENT MONTAGE	ENTRATA INPUT EINGANG	CODICE CODE BESTELLNUMMER
	giri/min r.p.m. U/min. min ⁻¹	POTENZA POWER LEISTUNG CV kW	COPPIA TORQUE DREHEM N·m	COPPIA TORQUE DREHEM N·m	giri/min r.p.m. U/min. min ⁻¹			
2:1	200	17 12.5	597	1160	100		Y	6073.318.020
3.3:1	200	12 8.8	421	1350	60		Y	6073.318.033
3.8:1	200	11 8	386	1425	52.6		Y	6073.318.038
3:1	200	12 9	422	1252	66.6		Y	6073.318.030S

PESO INDICATIVO APPROXIMATE WEIGHT GEWICHT CA.	OLIO CONSIGLIATO RECOMMENDED OIL EMPFOHLENES ÖL	MATERIALI MATERIALS WERKSTOFF			CUSCINETTI BEARINGS NADELLAGER				
		SCATOLA CASE GEHAUSE	ALBERI SHAFTS WELLEN	INGRANAGGI GEARS VERZÄHNUNG	A	B	C	D	E
Kg									
9	SAE 90 Kg 0.46	GD Al Si 12	20MnCr5	20MnCr5	6010	6010	6009	6009	

**SCATOLE PER POMPE OLEODINAMICHE
GEARBOX FOR HYDRAULIC GEAR PUMPS
GETRIEBE FÜR ÖLKRAFTZAHNRADERPUMPEN**

MP21

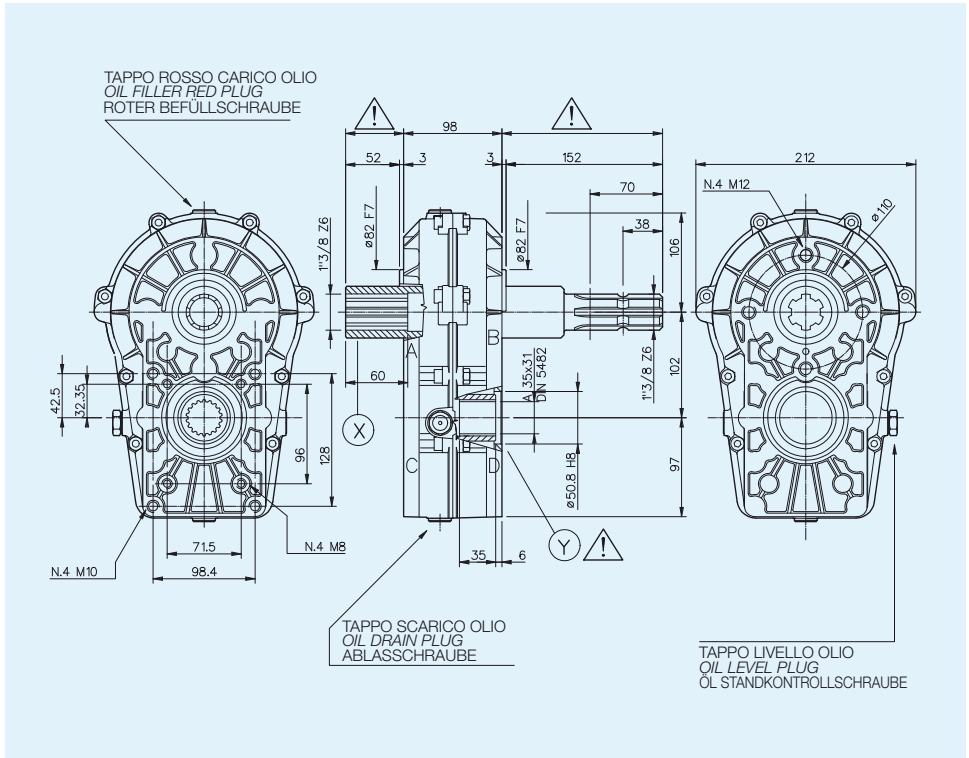

RAPPORTO RATIO VERHÄLTNIS	ENTRATA INPUT EINGANG		USCITA OUTPUT AUSGANG		MONTAGGIO ARRANGEMENT MONTAGE	ENTRATA INPUT EINGANG	CODICE CODE BESTELLNUMMER
	giri/min r.p.m. U/min. min ⁻¹	POTENZA POWER LEISTUNG CV kW	COPPIA TORQUE DREHEM N·m	COPPIA TORQUE DREHEM N·m			
1:3.8	540	31 22.8	404	108	2057	X	6073.319.038

PESO INDICATIVO APPROXIMATE WEIGHT GEWICHT CA.	OLIO CONSIGLIATO RECOMMENDED OIL EMPFOHLENES ÖL	MATERIALI MATERIALS WERKSTOFF			CUSCINETTI BEARINGS NADELLAGER					
		SCATOLA CASE GEHAUSE	ALBERI SHAFTS WELLEN	INGRANAGGI GEARS VERZÄHNUNG	A	B	C	D	E	
Kg										
9.5	SAE 90 Kg 0.46	GD Al Si 12	20MnCr5	20MnCr5	6010	6010	6009	6009		

SCATOLE PER POMPE OLEODINAMICHE GEARBOX FOR HYDRAULIC GEAR PUMPS GETRIEBE FÜR ÖLKRAFTZAHNRADERPUMPEN

MP21

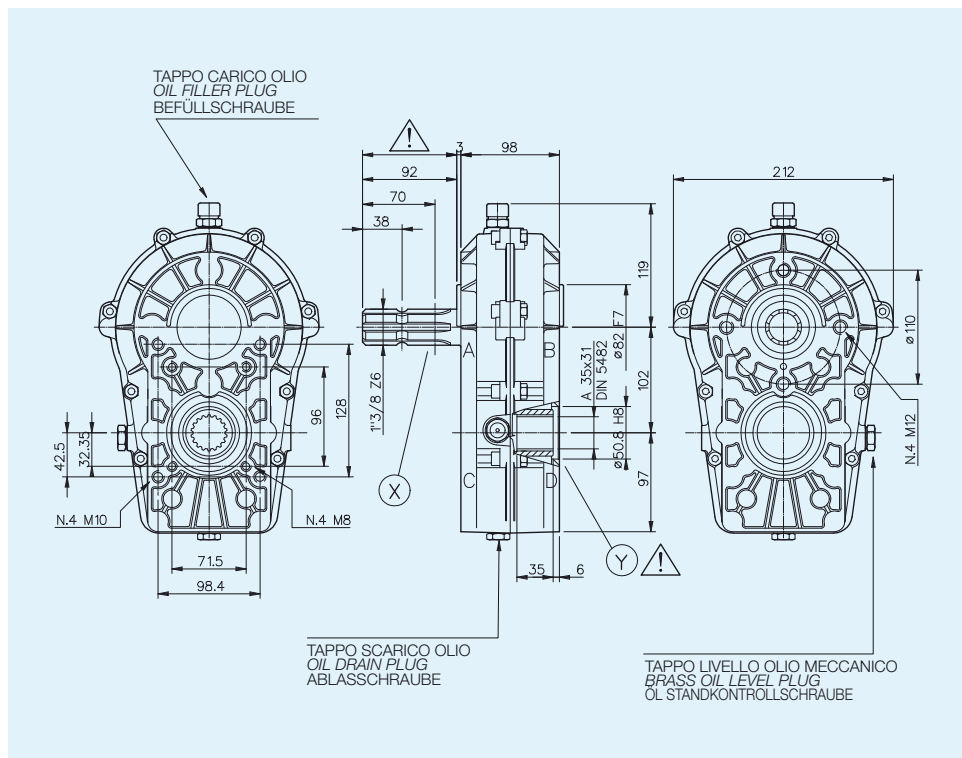

RAPPORTO RATIO VERHALTNIS	ENTRATA INPUT EINGANG		USCITA OUTPUT AUSGANG			MONTAGGIO ARRANGEMENT MONTAGE	ENTRATA INPUT EINGANG	CODICE CODE BESTELLNUMMER
	giri/min r.p.m. U/min. min ⁻¹	POTENZA POWER LEISTUNG CV kW	COPPIA TORQUE DREHEM N·m	COPPIA TORQUE DREHEM N·m	giri/min r.p.m. U/min. min ⁻¹			
1:2	540	32 23.5	425	217	1080		X	6073.323.020S
1:3.35	540	35 25.7	460	135	1809		X	6073.323.033S
1:3.8	540	31 22.8	404	108	2057		X	6073.323.038S

PESO INDICATIVO APPROXIMATE WEIGHT GEWICHT CA.	OLIO CONSIGLIATO RECOMMENDED OIL EMPFOHLENES ÖL	MATERIALI MATERIALS WERKSTOFF			CUSCINETTI BEARINGS NADELLAGER				
		SCATOLA CASE GEHAUSE	ALBERI SHAFTS WELLEN	INGRANAGGI GEARS VERZÄHNUNG	A	B	C	D	E
Kg									
9	SAE 90 Kg 0.46	GD Al Si 12	20MnCr5	20MnCr5	6010	6010	6009	6009	

**SCATOLE PER POMPE OLEODINAMICHE
GEARBOX FOR HYDRAULIC GEAR PUMPS
GETRIEBE FÜR ÖLKRAFTZAHNRADERPUMPEN**

MP21

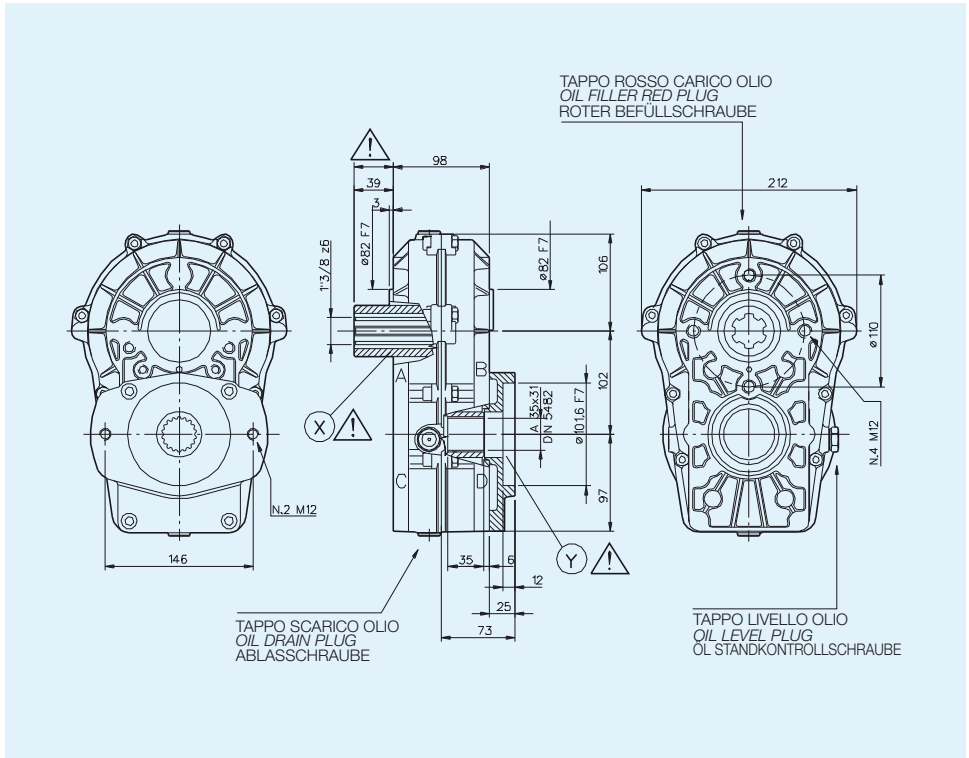

RAPPORTO RATIO VERHALTNIS	ENTRATA INPUT EINGANG		USCITA OUTPUT AUSGANG		MONTAGGIO ARRANGEMENT MONTAGE	ENTRATA INPUT EINGANG	CODICE CODE BESTELLNUMMER
	giri/min r.p.m. U/min. min ⁻¹	POTENZA POWER LEISTUNG CV kW	COPPIA TORQUE DREHEM N·m	COPPIA TORQUE DREHEM N·m			
1:3.8	540	31 22.8	404	108		X	6073.327.038
1:3	540	37 27.2	495	165		X	6073.327.030

PESO INDICATIVO APPROXIMATE WEIGHT GEWICHT CA.	OLIO CONSIGLIATO RECOMMENDED OIL EMPFOHLENES ÖL	MATERIALI MATERIALS WERKSTOFF			CUSCINETTI BEARINGS NADELLAGER				
		SCATOLA CASE GEHAUSE	ALBERI SHAFTS WELLEN	INGRANAGGI GEARS VERZÄHNUNG	A	B	C	D	E
Kg									
9.2	SAE 90 Kg 0.46	GD Al Si 12	20MnCr5	20MnCr5	6010	6010	6009	6009	

**SCATOLE PER POMPE OLEODINAMICHE
GEARBOX FOR HYDRAULIC GEAR PUMPS
GETRIEBE FÜR ÖLKRAFTZAHNRADERPUMPEN**

MP22

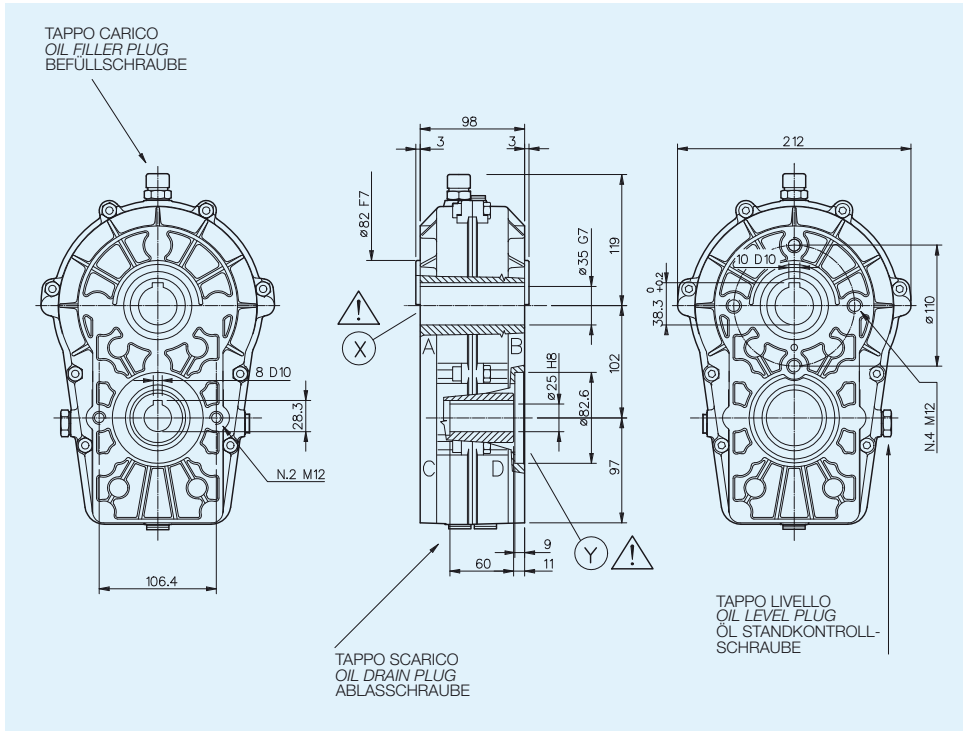

RAPPORTO RATIO VERHÄLTNIS	INGRESSO INPUT EINGANG			USCITA OUTPUT AUSGANG		MONTAGGIO ARRANGEMENT MONTAGE	ENTRATA INPUT EINGANG	CODICE CODE BESTELLNUMMER
	min ⁻¹	POTENZA POWER LEISTUNG CV kW	COPPIA TORQUE DREHM. N-m	COPPIA TORQUE DREHM. N-m	min ⁻¹			
2:1	200	8,4 6	295	567	100		Y	6075.303.020
3,3:1	200	4,8 3.5	172	567	60		Y	6075.303.033
3,8:1	200	4 3	149	567	52.6		Y	6075.303.038

PESO INDICATIVO APPROXIMATE WEIGHT GEWICHT CA.	OLIO CONSIGLIATO RECOMMENDED OIL EMPFOHLENES ÖL	MATERIALI MATERIALS WERKSTOFF			CUSCINETTI BEARINGS NADELLAGER				
		SCATOLA CASE GEHAUSE	ALBERI SHAFTS WELLEN	INGRANAGGI GEARS VERZÄHNUNG	A	B	C	D	E
Kg.	SAE 90 Kg.				A	B	C	D	E
9	0,46	GDAISI 12	20MnCr5	20MnCr5	6010	6010	6009	6009	

**SCATOLE PER POMPE OLEODINAMICHE
GEARBOX FOR HYDRAULIC GEAR PUMPS
GETRIEBE FÜR ÖLKRAFTZAHNRADERPUMPEN**

MP22

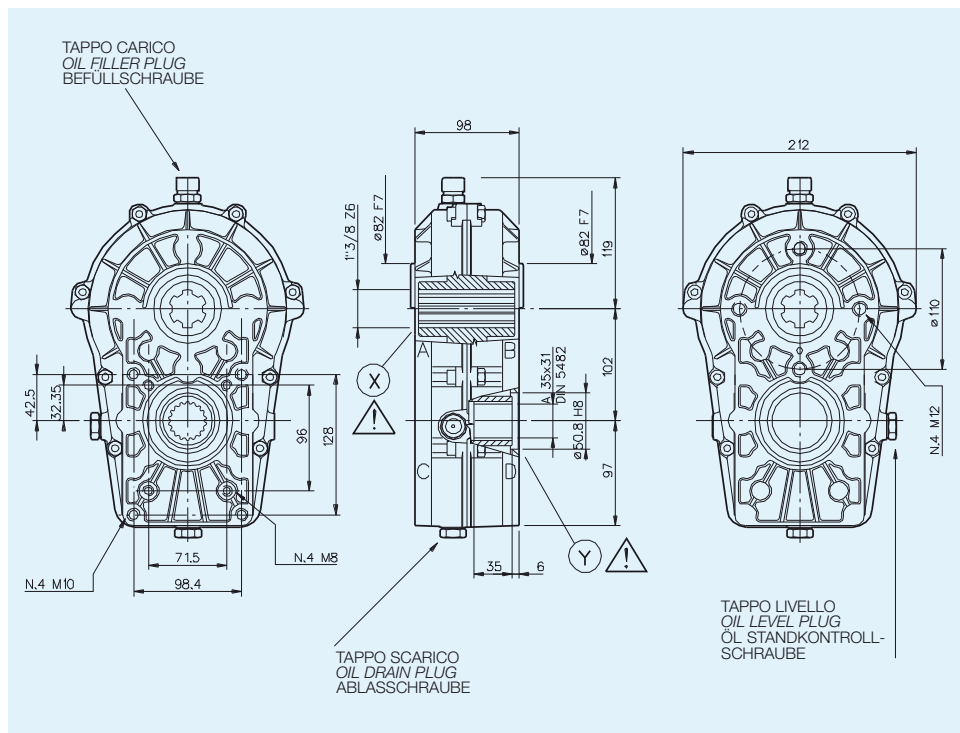

RAPPORTO RATIO VERHÄLTNIS	INGRESSO INPUT EINGANG				USCITA OUTPUT AUSGANG		MONTAGGIO ARRANGEMENT MONTAGE	ENTRATA INPUT EINGANG	CODICE CODE BESTELLNUMMER
	min ⁻¹	POTENZA POWER LEISTUNG		COPPIA TORQUE DREHM.	COPPIA TORQUE DREHM.	min ⁻¹			
		CV	kW	N-m	N-m				
1:3	540	37	27.2	495	165	1620		X	6075.302.030
1:3,35	540	35	25.2	460	135	1809		X	6075.302.033
1:3,8	540	31	22.8	404	108	2057		X	6075.302.038

PESO INDICATIVO APPROXIMATE WEIGHT GEWICHT CA.	OLIO CONSIGLIATO RECOMMENDED OIL EMPFOHLENES ÖL	MATERIALI MATERIALS WERKSTOFF			CUSCINETTI BEARINGS NADELLAGER				
		SCATOLA CASE GEHAUSE	ALBERI SHAFTS WELLEN	INGRANAGGI GEARS VERZÄHNUNG	A	B	C	D	E
Kg.	SAE 90 Kg.								
9	0,46	GDAISI 12	20MnCr5	20MnCr5	6010	6010	6009	6009	

**SCATOLE PER POMPE OLEODINAMICHE
GEARBOX FOR HYDRAULIC GEAR PUMPS
GETRIEBE FÜR ÖLKRAFTZAHNRADERPUMPEN**

MP22

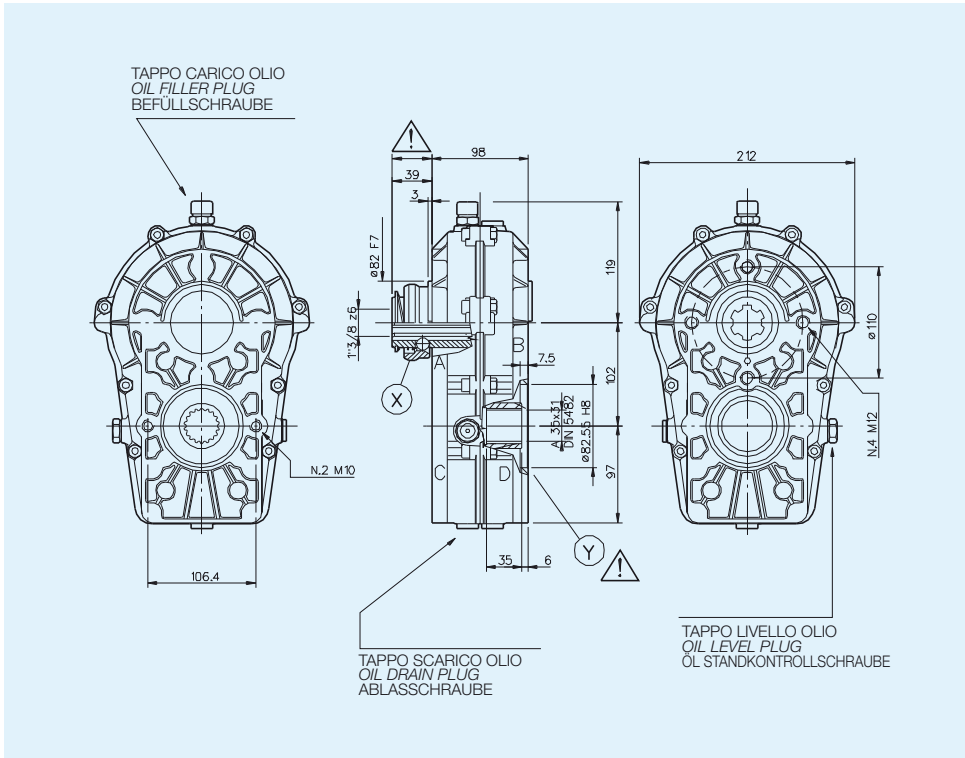

RAPPORTO RATIO VERHALTNIS	ENTRATA INPUT EINGANG		USCITA OUTPUT AUSGANG			MONTAGGIO ARRANGEMENT MONTAGE	ENTRATA INPUT EINGANG	CODICE CODE BESTELLNUMMER
	giri/min r.p.m. U/min. min ⁻¹	POTENZA POWER LEISTUNG CV kW	COPPIA TORQUE DREHEM N·m	COPPIA TORQUE DREHEM N·m	giri/min r.p.m. U/min. min ⁻¹			
1:3	540	37 27.2	495	165	1620		X	6075.305.030
1:3.35	540	35 25.7	460	135	1809		X	6075.305.033
1:3.8	540	31 22.8	404	108	2057		X	6075.305.038

PESO INDICATIVO APPROXIMATE WEIGHT GEWICHT CA.	OLIO CONSIGLIATO RECOMMENDED OIL EMPFOHLENES ÖL	MATERIALI MATERIALS WERKSTOFF			CUSCINETTI BEARINGS NADELLAGER					
		SCATOLA CASE GEHAUSE	ALBERI SHAFTS WELLEN	INGRANAGGI GEARS VERZAHNUNG	A	B	C	D	E	
kg										
9	SAE 90 kg 0.46	GD Al Si 12	20MnCr5	20MnCr5	6010	6010	6009	6009		

**SCATOLE PER POMPE OLEODINAMICHE
GEARBOX FOR HYDRAULIC GEAR PUMPS
GETRIEBE FÜR ÖLKRAFTZAHNRADERPUMPEN**

MP22

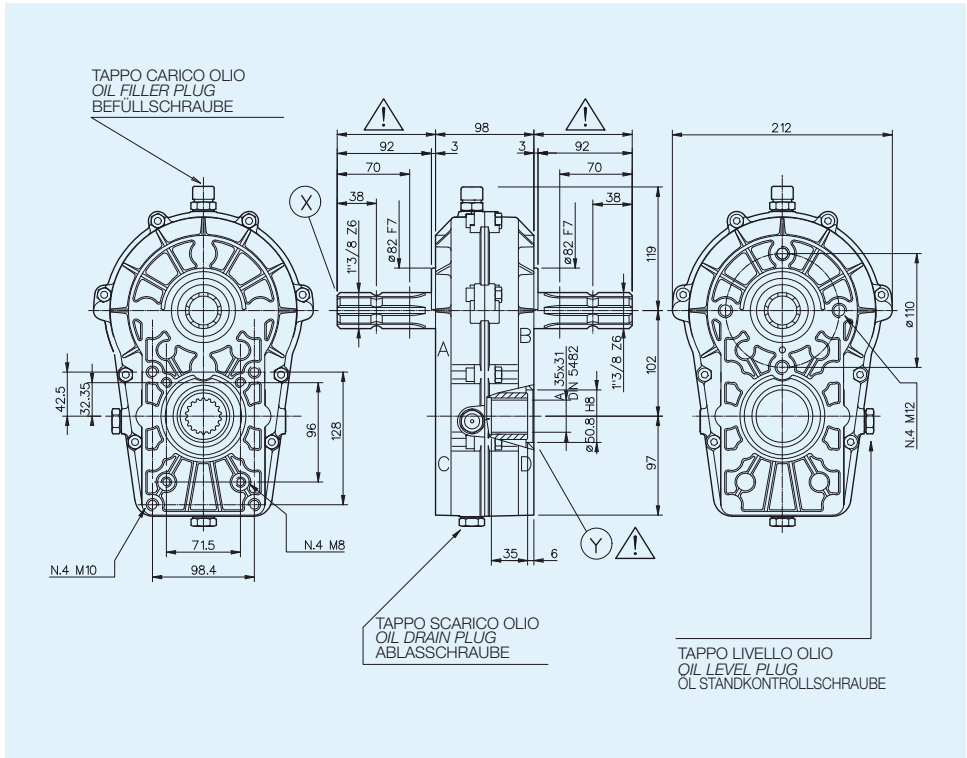

RAPPORTO RATIO VERHÄLTNIS	ENTRATA INPUT EINGANG		USCITA OUTPUT AUSGANG		MONTAGGIO ARRANGEMENT MONTAGE	ENTRATA INPUT EINGANG	CODICE CODE BESTELLNUMMER
	giri/min r.p.m. U/min. min ⁻¹	POTENZA POWER LEISTUNG CV kW	COPPIA TORQUE DREHEM N·m	COPPIA TORQUE DREHEM N·m			
1:3	540	37 27.2	495	165	1620	X	6075.306.030
1:3.35	540	35 25.7	460	135	1809	X	6075.306.033
1:3.8	540	31 22.8	404	108	2057	X	6075.306.038

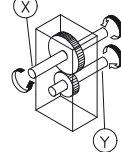

PESO INDICATIVO APPROXIMATE WEIGHT GEWICHT CA. kg	OLIO CONSIGLIATO RECOMMENDED OIL EMPFOHLENES ÖL	MATERIALI MATERIALS WERKSTOFF			CUSCINETTI BEARINGS NADELLAGER				
		SCATOLA CASE GEHAUSE	ALBERI SHAFTS WELLEN	INGRANAGGI GEARS VERZÄHNUNG	A	B	C	D	E
9.5	SAE 90 kg 0.46	GD Al Si 12	20MnCr5	20MnCr5	6010	6010	6009	6009	

**SCATOLE PER POMPE OLEODINAMICHE
GEARBOX FOR HYDRAULIC GEAR PUMPS
GETRIEBE FÜR ÖLKRAFTZAHNRADERPUMPEN**

MP22

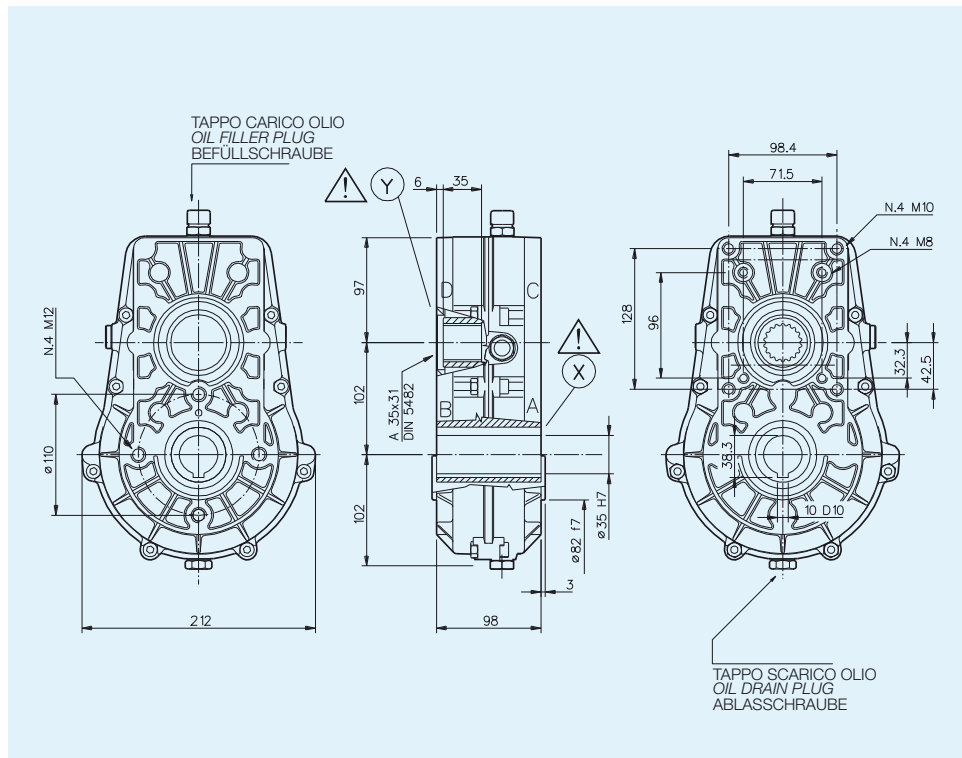

RAPPORTO RATIO VERHALTNIS	ENTRATA INPUT EINGANG		USCITA OUTPUT AUSGANG			MONTAGGIO ARRANGEMENT MONTAGE	ENTRATA INPUT EINGANG	CODICE CODE BESTELLNUMMER
	giri/min r.p.m. U/min. min ⁻¹	POTENZA POWER LEISTUNG CV kW	COPPIA TORQUE DREHEM N·m	COPPIA TORQUE DREHEM N·m	giri/min r.p.m. U/min. min ⁻¹			
1:2	540	32 23.5	425	217	1080		X	6075.309.020
1:3	540	37 27.2	495	165	1620		X	6075.309.030
1:3.35	540	35 25.7	460	135	1809		X	6075.309.033
1:3.8	540	31 22.8	404	108	2057		X	6075.309.038

PESO INDICATIVO APPROXIMATE WEIGHT GEWICHT CA.	OLIO CONSIGLIATO RECOMMENDED OIL EMPFOHLENES ÖL	MATERIALI MATERIALS WERKSTOFF			CUSCINETTI BEARINGS NADELLAGER				
		SCATOLA CASE GEHAUSE	ALBERI SHAFTS WELLEN	INGRANAGGI GEARS VERZÄHNUNG	A	B	C	D	E
kg									
9	SAE 90 kg 0.46	GD Al Si 12	20MnCr5	20MnCr5	6010	6010	6009	6009	

**SCATOLE PER POMPE OLEODINAMICHE
GEARBOX FOR HYDRAULIC GEAR PUMPS
GETRIEBE FÜR ÖLKRAFTZAHNRADERPUMPEN**

MP22

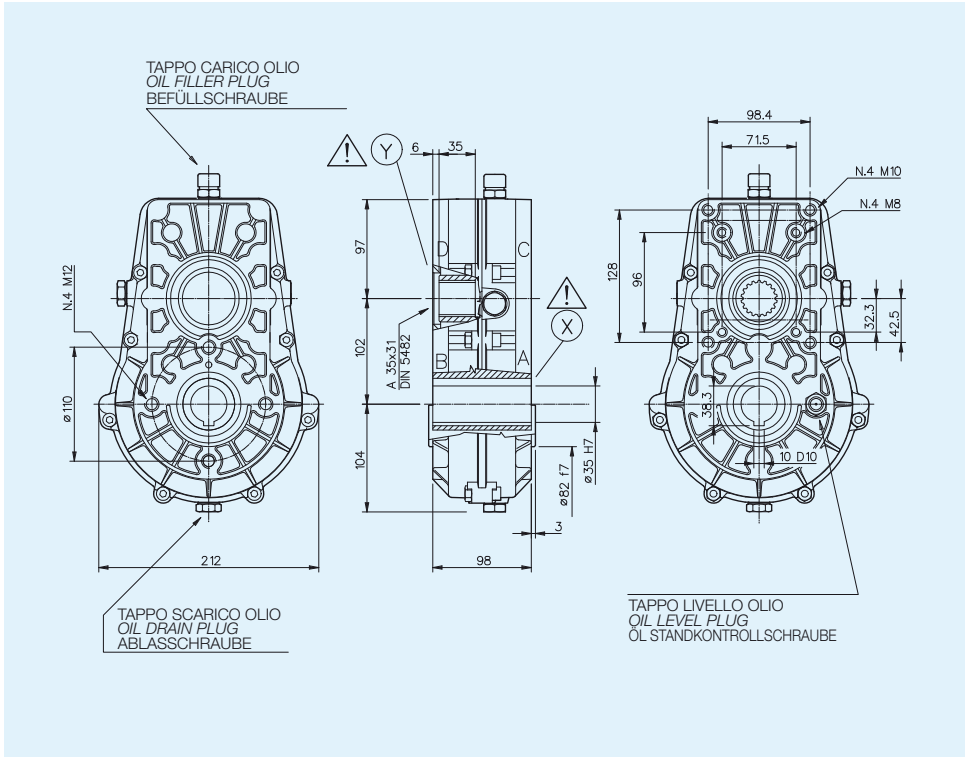

RAPPORTO RATIO VERHÄLTNIS	ENTRATA INPUT EINGANG		USCITA OUTPUT AUSGANG		MONTAGGIO ARRANGEMENT MONTAGE	ENTRATA INPUT EINGANG	CODICE CODE BESTELLNUMMER
	giri/min r.p.m. U/min. min ⁻¹	POTENZA POWER LEISTUNG CV kW	COPPIA TORQUE DREHEM N·m	COPPIA TORQUE DREHEM N·m			
1:2	540	32 23.5	425	217		X	6075.310.020
1:3	540	37 27.2	495	165		X	6075.310.030
1:3.35	540	35 25.7	460	135		X	6075.310.033
1:3.8	540	31 22.8	404	108		X	6075.310.038

PESO INDICATIVO APPROXIMATE WEIGHT GEWICHT CA. kg	OLIO CONSIGLIATO RECOMMENDED OIL EMPFOHLENES ÖL	MATERIALI MATERIALS WERKSTOFF			CUSCINETTI BEARINGS NADELLAGER				
		SCATOLA CASE GEHAUSE	ALBERI SHAFTS WELLEN	INGRANAGGI GEARS VERZÄHNUNG	A	B	C	D	E
9	SAE 90 kg 0.46	GD Al Si 12	20MnCr5	20MnCr5	6010	6010	6009	6009	

**SCATOLE PER POMPE OLEODINAMICHE
GEARBOX FOR HYDRAULIC GEAR PUMPS
GETRIEBE FÜR ÖLKRAFTZAHNRADERPUMPEN**

MP22

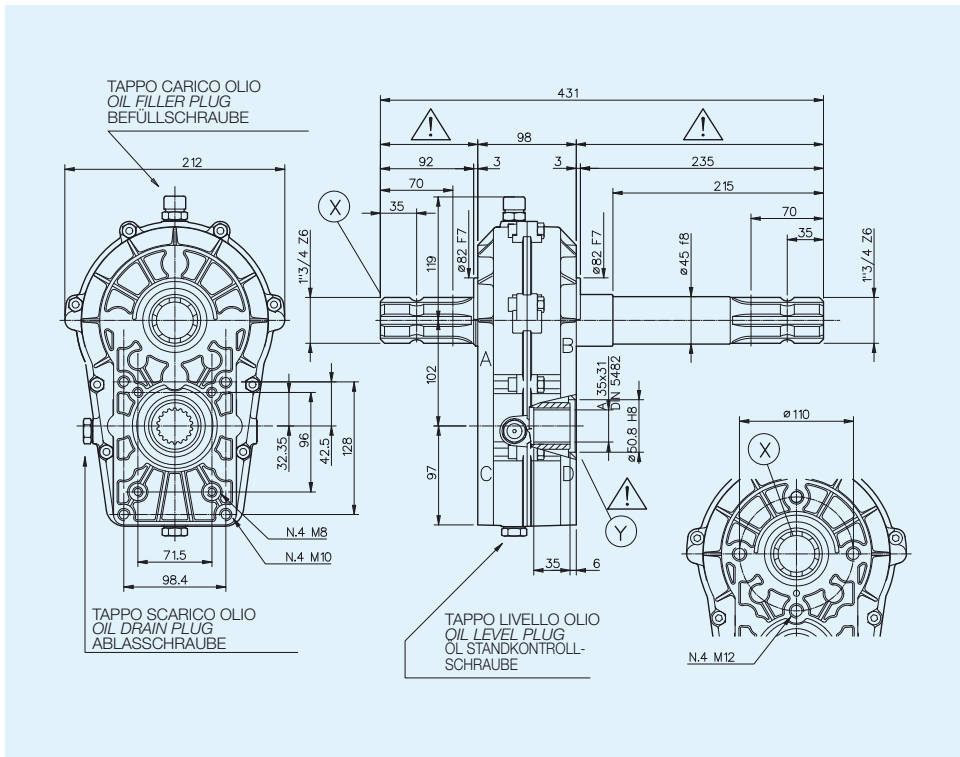

RAPPORTO RATIO VERHALTNIS	ENTRATA INPUT EINGANG		USCITA OUTPUT AUSGANG			MONTAGGIO ARRANGEMENT MONTAGE	ENTRATA INPUT EINGANG	CODICE CODE BESTELLNUMMER
	giri/min r.p.m. U/min. min ⁻¹	POTENZA POWER LEISTUNG CV kW	COPPIA TORQUE DREHEM N·m	COPPIA TORQUE DREHEM N·m	giri/min r.p.m. U/min. min ⁻¹			
1:2	540	32 23.5	425	217	1080		X	6075.312.020
1:3.35	540	35 25.7	460	135	1809		X	6075.312.033
1:3.8	540	31 22.8	404	108	2057		X	6075.312.038

PESO INDICATIVO APPROXIMATE WEIGHT GEWICHT CA.	OLIO CONSIGLIATO RECOMMENDED OIL EMPFOHLENES ÖL	MATERIALI MATERIALS WERKSTOFF			CUSCINETTI BEARINGS NADELLAGER				
		SCATOLA CASE GEHAUSE	ALBERI SHAFTS WELLEN	INGRANAGGI GEARS VERZÄHNUNG	A	B	C	D	E
kg									
9.5	SAE 90 kg 0.46	GD Al Si 12	20MnCr5	20MnCr5	6010	6010	6009	6009	

SCATOLE PER POMPE OLEODINAMICHE GEARBOX FOR HYDRAULIC GEAR PUMPS GETRIEBE FÜR ÖLKRAFTZAHNRADERPUMPEN

M6

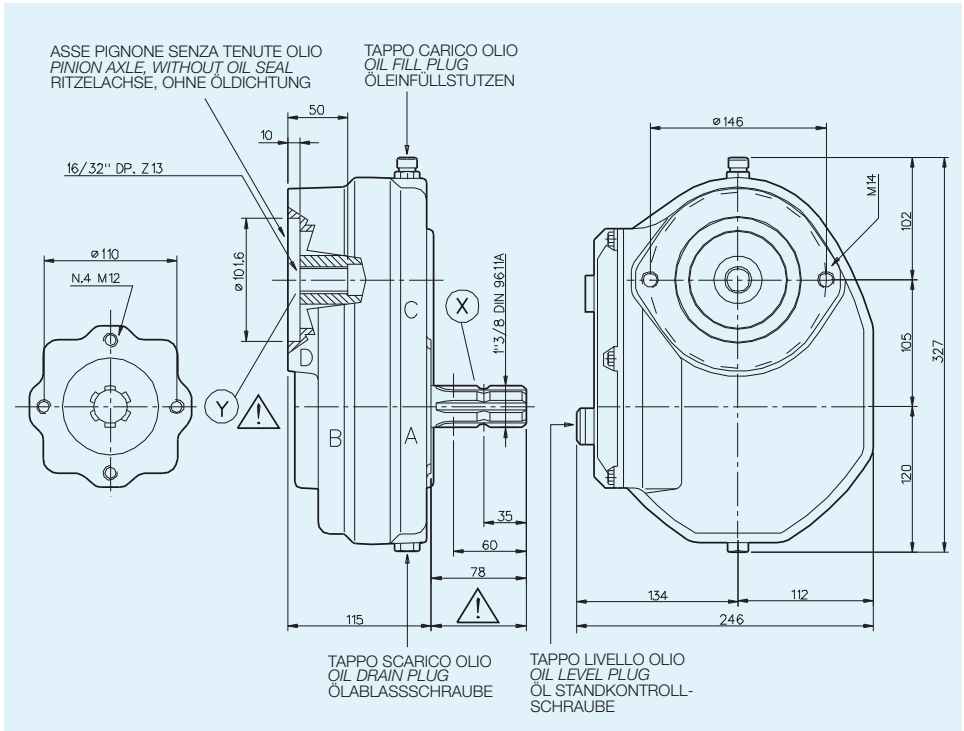

RAPPORTO RATIO VERHÄLTNIS	INGRESSO INPUT EINGANG		USCITA OUTPUT AUSGANG		MONTAGGIO ARRANGEMENT MONTAGE	ENTRATA INPUT EINGANG	CODICE CODE BESTELLNUMMER	
	min ⁻¹	POTENZA POWER LEISTUNG CV kW	COPPIA TORQUE DREHM. N-m	COPPIA TORQUE DREHM. N-m				min ⁻¹
1:3	540	45 33	596	196	1620	X	6061.303.030	
PESO INDICATIVO APPROXIMATE WEIGHT GEWICHT CA. Kg.	OLIO CONSIGLIATO RECOMMENDED OIL EMPFOHLENES ÖL SAE 90 Kg.		MATERIALI MATERIALS WERKSTOFF	CUSCINETTI BEARINGS NADELLAGER				
	SCATOLA CASE GEHAUSE G 25	ALBERI SHAFTS WELLEN 20MnCr5	INGRANAGGI GEARS VERZÄHNUNG 20MnCr5	A	B	C	D	E
				6307	6307	6208	6208	

SCATOLE PER POMPE OLEODINAMICHE GEARBOX FOR HYDRAULIC GEAR PUMPS GETRIEBE FÜR ÖLKRAFTZAHNRADERPUMPEN

M6

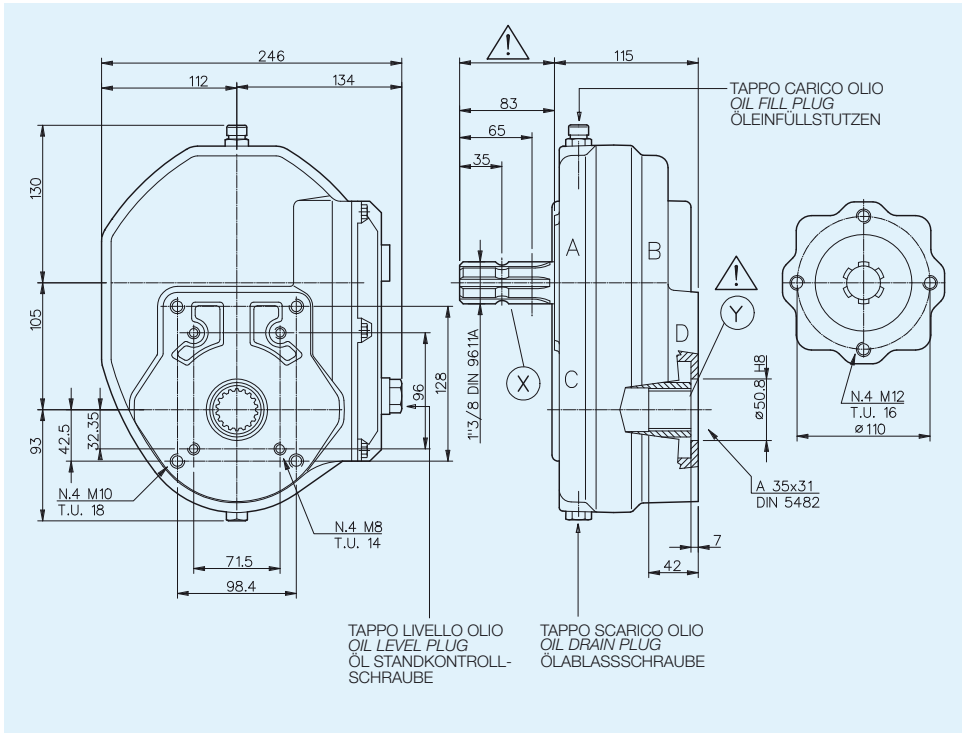

RAPPORTO RATIO VERHÄLTNIS	INGRESSO INPUT EINGANG		COPPIA TORQUE DREHM.		USCITA OUTPUT AUSGANG		MONTAGGIO ARRANGEMENT MONTAGE	ENTRATA INPUT EINGANG	CODICE CODE BESTELLNUMMER
	min ⁻¹	POTENZA POWER LEISTUNG CV	POTENZA POWER LEISTUNG kW	N-m	N-m	min ⁻¹			
1:2	1000	60	44	421	203	2000		X	6061.307.020
1:3,5	540	45	33	596	168	1890		X	6061.307.035

PESO INDICATIVO APPROXIMATE WEIGHT GEWICHT CA.	OLIO CONSIGLIATO RECOMMENDED OIL EMPFOHLENES ÖL	MATERIALI MATERIALS WERKSTOFF			CUSCINETTI BEARINGS NADELLAGER				
		SCATOLA CASE GEHAUSE	ALBERI SHAFTS WELLEN	INGRANAGGI GEARS VERZÄHNUNG	A	B	C	D	E
Kg.	SAE 90 Kg.	G 25	20MnCr5	20MnCr5	6307	6307	6010	6010	
17,8									

SCATOLE PER POMPE OLEODINAMICHE GEARBOX FOR HYDRAULIC GEAR PUMPS GETRIEBE FÜR ÖLKRAFTZAHNRADERPUMPEN

M6

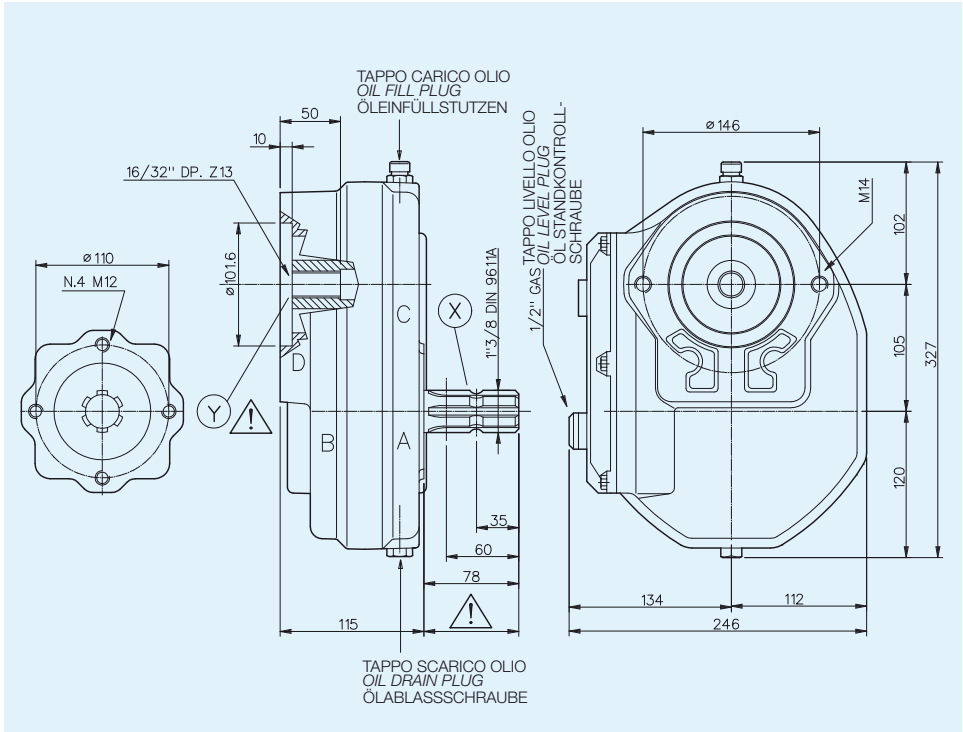

RAPPORTO RATIO VERHÄLTNIS	INGRESSO INPUT EINGANG			USCITA OUTPUT AUSGANG		MONTAGGIO ARRANGEMENT MONTAGE	ENTRATA INPUT EINGANG	CODICE CODE BESTELLNUMMER				
	min ⁻¹	POTENZA POWER LEISTUNG CV	kW	COPPIA TORQUE DREHM. N-m	COPPIA TORQUE DREHM. N-m				min ⁻¹			
1:3,5	540	45	33	596	168	1890	X	6061.306.035				
PESO INDICATIVO APPROXIMATE WEIGHT GEWICHT CA.	OLIO CONSIGLIATO RECOMMENDED OIL EMPFOHLENES ÖL			MATERIALI MATERIALS WERKSTOFF			CUSCINETTI BEARINGS NADELLAGER					
	Kg.	SAE 90 Kg.			SCATOLA CASE GEHAUSE	ALBERI SHAFTS WELLEN	INGRANAGGI GEARS VERZÄHNUNG	A	B	C	D	E
	1				G 25	20MnCr5	20MnCr5	6307	6307	30208	30208	

SCATOLE PER POMPE OLEODINAMICHE GEARBOX FOR HYDRAULIC GEAR PUMPS GETRIEBE FÜR ÖLKRAFTZAHNRADERPUMPEN

M6

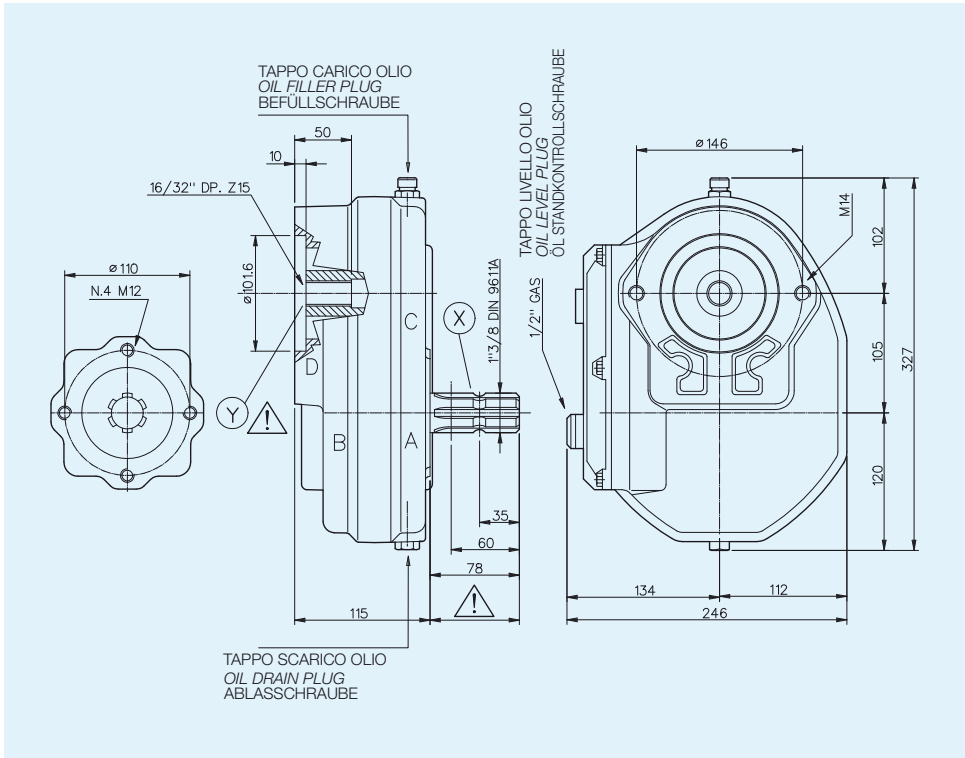

RAPPORTO RATIO VERHÄLTNIS	ENTRATA INPUT EINGANG		USCITA OUTPUT AUSGANG			MONTAGGIO ARRANGEMENT MONTAGE	ENTRATA INPUT EINGANG	CODICE CODE BESTELLNUMMER
	giri/min r.p.m. U/min. min ⁻¹	POTENZA POWER LEISTUNG CV kW	COPPIA TORQUE DREHEM N·m	COPPIA TORQUE DREHEM N·m	giri/min r.p.m. U/min. min ⁻¹			
1:2	1000	45 33	316	152	2000		X	6061.312.020
1:3.5	540	45 33	596	168	1890		X	6061.312.035

PESO INDICATIVO APPROXIMATE WEIGHT GEWICHT CA. kg	OLIO CONSIGLIATO RECOMMENDED OIL EMPFOHLENES ÖL SAE 90 kg 1	MATERIALI MATERIALS WERKSTOFF			CUSCINETTI BEARINGS NADELLAGER				
		SCATOLA CASE GEHAUSE	ALBERI SHAFTS WELLEN	INGRANAGGI GEARS VERZÄHNUNG	A	B	C	D	E
17,5	SAE 90 kg 1	G 25	20MnCr5	20MnCr5	6307	6307	30307 30208	30307 30208	R.1:3.5

SCATOLE PER POMPE OLEODINAMICHE GEARBOX FOR HYDRAULIC GEAR PUMPS GETRIEBE FÜR ÖLKRAFTZAHNRADERPUMPEN

M6

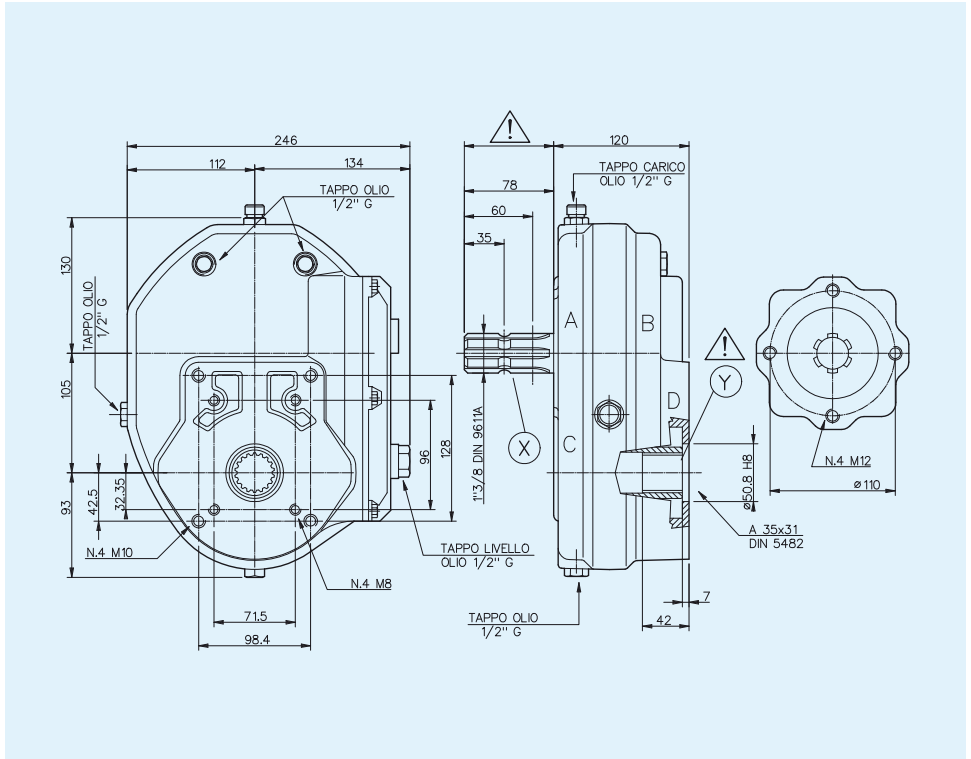

RAPPORTO RATIO VERHÄLTNIS	ENTRATA INPUT EINGANG		USCITA OUTPUT AUSGANG		MONTAGGIO ARRANGEMENT MONTAGE	ENTRATA INPUT EINGANG	CODICE CODE BESTELLNUMMER
	giri/min r.p.m. U/min. min ⁻¹	POTENZA POWER LEISTUNG CV kW	COPPIA TORQUE DREHEM N·m	COPPIA TORQUE DREHEM N·m			
1:3.5	540	45 33	596	168	1890	X	6061.326.035

PESO INDICATIVO APPROXIMATE WEIGHT GEWICHT CA.	OLIO CONSIGLIATO RECOMMENDED OIL EMPFOHLENES ÖL	MATERIALI MATERIALS WERKSTOFF			CUSCINETTI BEARINGS NADELLAGER				
		SCATOLA CASE GEHAUSE	ALBERI SHAFTS WELLEN	INGRANAGGI GEARS VERZÄHNUNG	A	B	C	D	E
kg									
19	SAE 90 kg 1	G 25	20MnCr5	20MnCr5	6307	6307	32010	32010	

SCATOLE PER POMPE OLEODINAMICHE GEARBOX FOR HYDRAULIC GEAR PUMPS GETRIEBE FÜR ÖLKRAFTZAHNRADERPUMPEN

M7

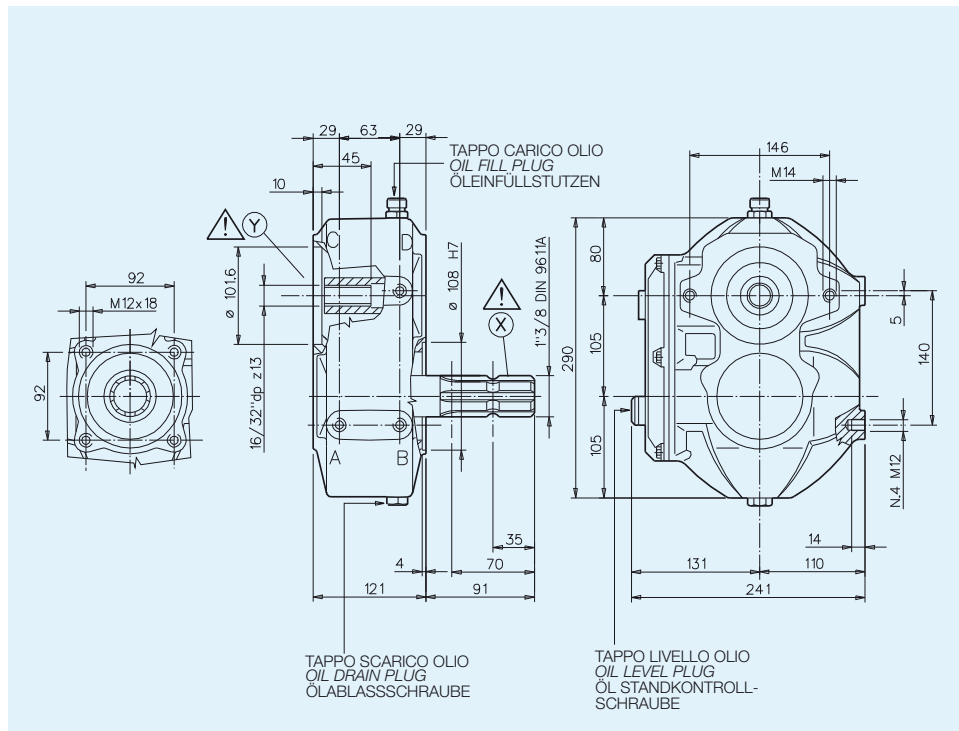

RAPPORTO RATIO VERHÄLTNIS	INGRESSO INPUT EINGANG				USCITA OUTPUT AUSGANG		MONTAGGIO ARRANGEMENT MONTAGE	ENTRATA INPUT EINGANG	CODICE CODE BESTELLNUMMER
	min ⁻¹	POTENZA POWER LEISTUNG		COPPIA TORQUE DREHM.		min ⁻¹			
		CV	kW	N-m	N-m				
1:1,93	540	70	51.5	928	482	1026		X	6005.312.020
1:2,5	540	60	44	795	310	1350		X	6005.312.025
1:3	540	60	44	795	256	1620		X	6005.312.030
1:3,57	540	60	44	795	214	1928		X	6005.312.035
1:4	540	60	44	795	195	2160		X	6005.312.040
1:5	540	60	44	795	153	2700		X	6005.312.050
5:1	2700	60	44	156	795	540		Y	

PESO INDICATIVO APPROXIMATE WEIGHT GEWICHT CA.	OLIO CONSIGLIATO RECOMMENDED OIL EMPFOHLENES ÖL	MATERIALI MATERIALS WERKSTOFF			CUSCINETTI BEARINGS NADELLAGER				
		SCATOLA CASE GEHAUSE	ALBERI SHAFTS WELLEN	INGRANAGGI GEARS VERZÄHNUNG	A	B	C	D	E
Kg.	SAE 90 Kg.								
21	1,2	G 25	20MnCr5	20MnCr5	6210	6210	6208	6208	

SCATOLE PER POMPE OLEODINAMICHE GEARBOX FOR HYDRAULIC GEAR PUMPS GETRIEBE FÜR ÖLKRAFTZAHNRADERPUMPEN

M7

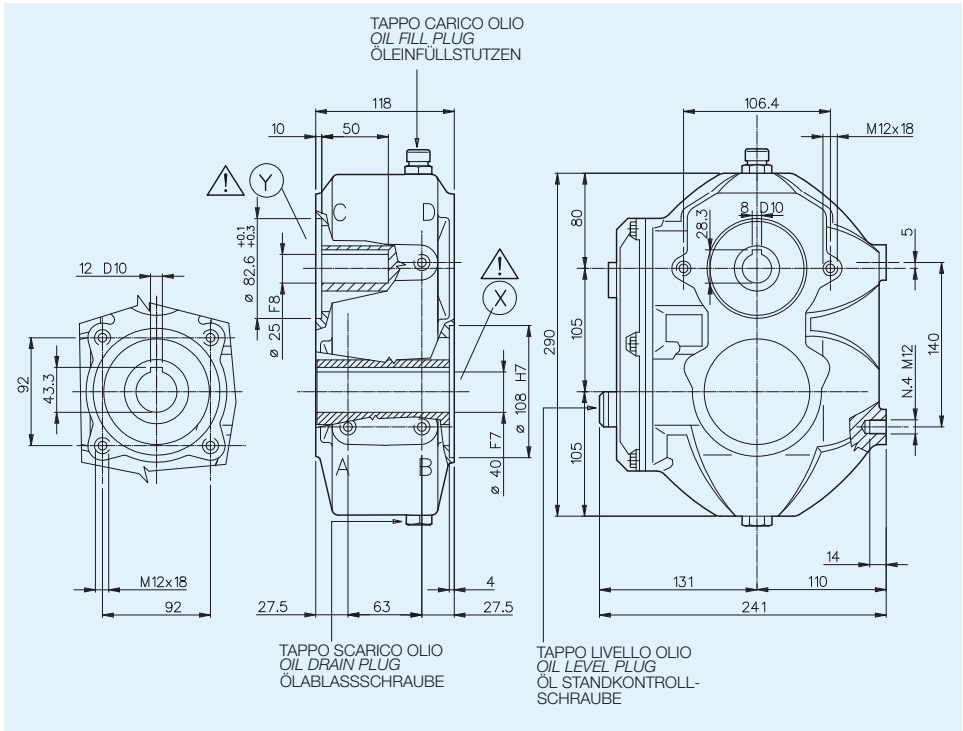

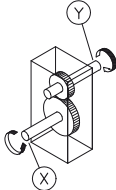
RAPPORTO RATIO VERHÄLTNIS	INGRESSO INPUT EINGANG			USCITA OUTPUT AUSGANG			MONTAGGIO ARRANGEMENT MONTAGE	ENTRATA INPUT EINGANG	CODICE CODE BESTELLNUMMER
	min ⁻¹	POTENZA POWER LEISTUNG CV	kW	COPPIA TORQUE DREHM. N-m	COPPIA TORQUE DREHM. N-m	min ⁻¹			
4:1	300	10	7.3	238	940	75		Y	6005.322.040

PESO INDICATIVO APPROXIMATE WEIGHT GEWICHT CA.	OLIO CONSIGLIATO RECOMMENDED OIL EMPFOHLENES ÖL	MATERIALI MATERIALS WERKSTOFF			CUSCINETTI BEARINGS NADELLAGER				
		SCATOLA CASE GEHAUSE	ALBERI SHAFTS WELLEN	INGRANAGGI GEARS VERZÄHNUNG	A	B	C	D	E
Kg. 23	SAE 90 Kg. 2	G 25	20MnCr5	20MnCr5	6011	6011	6208	6208	

SCATOLE PER POMPE OLEODINAMICHE GEARBOX FOR HYDRAULIC GEAR PUMPS GETRIEBE FÜR ÖLKRAFTZAHNRADERPUMPEN

M7

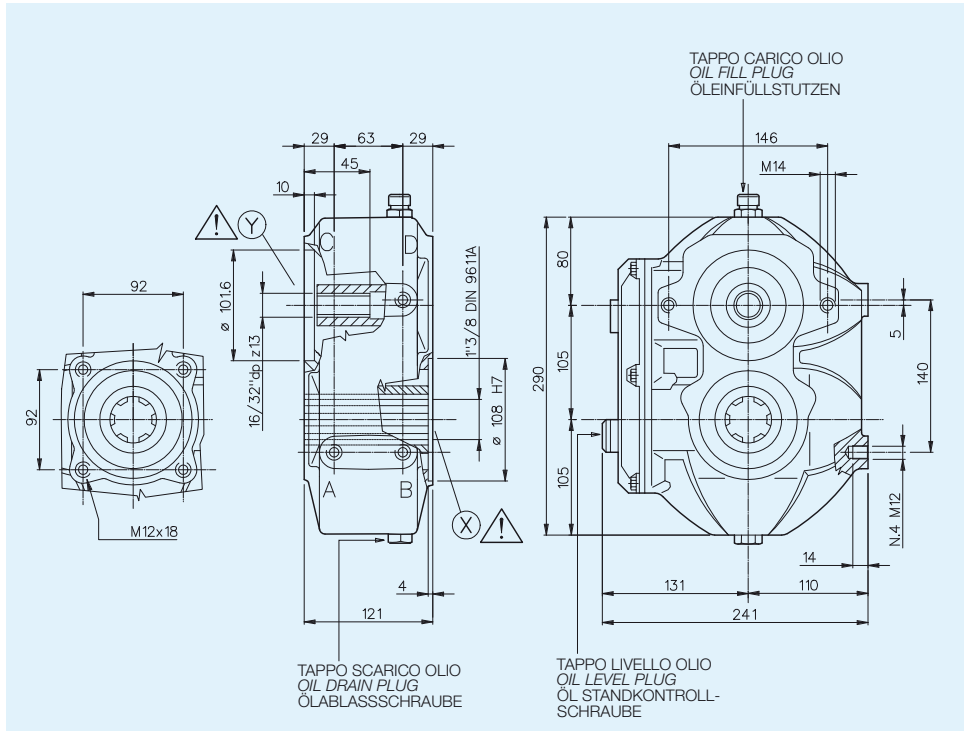

RAPPORTO RATIO VERHÄLTNIS	INGRESSO INPUT EINGANG			USCITA OUTPUT AUSGANG		MONTAGGIO ARRANGEMENT MONTAGE	ENTRATA INPUT EINGANG	CODICE CODE BESTELLNUMMER
	min ⁻¹	POTENZA POWER LEISTUNG CV	kW	COPPIA TORQUE DREHM. N-m	COPPIA TORQUE DREHM. N-m			
1:2	540	70	51.5	928	482	1026	X	6005.327.020
1:2,5	540	60	44	795	300	1350	X	6005.327.025
1:3	540	60	44	795	256	1620	X	6005.327.030
1:3,5	540	60	44	795	214	1628	X	6005.327.035
1:4	540	60	44	795	190	2160	X	6005.327.040
1:5	540	60	44	795	153	2700	X	6005.327.050

PESO INDICATIVO APPROXIMATE WEIGHT GEWICHT CA. Kg.	OLIO CONSIGLIATO RECOMMENDED OIL EMPFOHLENES ÖL SAE 90 Kg.	SCATOLA CASE GEHAUSE G 25	MATERIALI MATERIALS WERKSTOFF		CUSCINETTI BEARINGS NADELLAGER				
			ALBERI SHAFTS WELLEN 20MnCr5	INGRANAGGI GEARS VERZÄHNUNG 20MnCr5	A	B	C	D	E
21	2	G 25	20MnCr5	20MnCr5	6210	6210	6307	6307	

SCATOLE PER POMPE OLEODINAMICHE GEARBOX FOR HYDRAULIC GEAR PUMPS GETRIEBE FÜR ÖLKRAFTZAHNRADERPUMPEN

M7

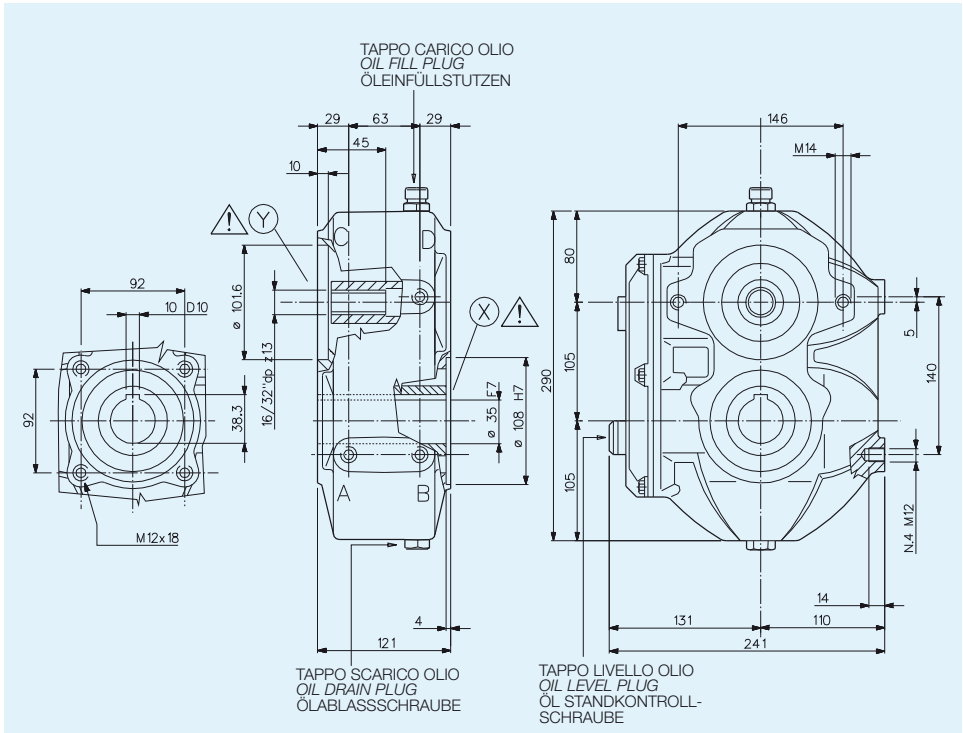

RAPPORTO RATIO VERHÄLTNIS	INGRESSO INPUT EINGANG		USCITA OUTPUT AUSGANG		MONTAGGIO ARRANGEMENT MONTAGE	ENTRATA INPUT EINGANG	CODICE CODE BESTELLNUMMER	
	POTENZA POWER LEISTUNG	COPPIA TORQUE DREHM.	COPPIA TORQUE DREHM.	min ⁻¹				
	min ⁻¹	CV	kW	N-m	N-m	min ⁻¹		
1:2,5	540	60	44	795	310	1350	X	6005.342.025
1:3	540	60	44	795	256	1620	X	6005.342.030
1:3,57	540	60	44	795	214	1928	X	6005.342.035
1:4	540	60	44	795	195	2160	X	6005.342.040
1:5	540	60	44	795	153	2700	X	6005.342.050

PESO INDICATIVO APPROXIMATE WEIGHT GEWICHT CA.	OLIO CONSIGLIATO RECOMMENDED OIL EMPFOHLENES ÖL	MATERIALI MATERIALS WERKSTOFF			CUSCINETTI BEARINGS NADELLAGER				
		SCATOLA CASE GEHAUSE	ALBERI SHAFTS WELLEN	INGRANAGGI GEARS VERZÄHNUNG	A	B	C	D	E
Kg.	SAE 90 Kg.								
21	2	G 25	20MnCr5	20MnCr5	6210	6210	6307	6307	

SCATOLE PER POMPE OLEODINAMICHE GEARBOX FOR HYDRAULIC GEAR PUMPS GETRIEBE FÜR ÖLKRAFTZAHNRADERPUMPEN

M7

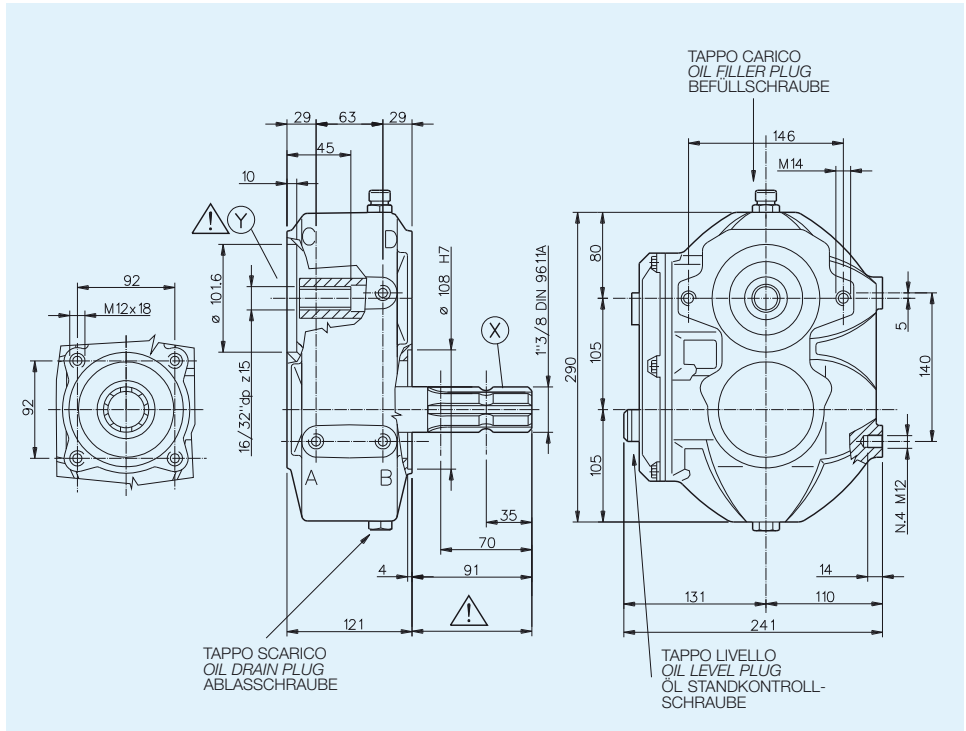

RAPPORTO RATIO VERHÄLTNIS	INGRESSO INPUT EINGANG			USCITA OUTPUT AUSGANG		MONTAGGIO ARRANGEMENT MONTAGE	ENTRATA INPUT EINGANG	CODICE CODE BESTELLNUMMER
	min ⁻¹	POTENZA POWER LEISTUNG CV	kW	COPPIA TORQUE DREHM. N-m	COPPIA TORQUE DREHM. N-m			
1:1,5	540	70	51.5	928	600	810	X	6005.345.015
	1000	90	66	644	416	1500		
1:2	540	70	51.5	928	482	1026	X	6005.345.020
	1000	60	44	795	310	1350	X	6005.345.025
1:3	540	60	44	795	255	2500		
	1000	90	66	644	256	1620	X	6005.345.030
1:3,57	540	60	44	795	214	1928	X	6005.345.035
	1000	60	44	795	195	2160	X	6005.345.040
1:4	540	60	44	795	153	2700	X	6005.345.050
	1000	60	44	795				

PESO INDICATIVO APPROXIMATE WEIGHT GEWICHT CA.	OLIO CONSIGLIATO RECOMMENDED OIL EMPFOHLENES ÖL	MATERIALI MATERIALS WERKSTOFF			CUSCINETTI BEARINGS NADELLAGER					
		SCATOLA CASE GEHAUSE	ALBERI SHAFTS WELLEN	INGRANAGGI GEARS VERZÄHNUNG	A	B	C	D	E	
Kg.	ISO VG 150-320 Kg.									
21	1,2	G 25	20MnCr5	20MnCr5	6210	6210	6208	6208		

SCATOLE PER POMPE OLEODINAMICHE GEARBOX FOR HYDRAULIC GEAR PUMPS GETRIEBE FÜR ÖLKRAFTZAHNRADERPUMPEN

M7

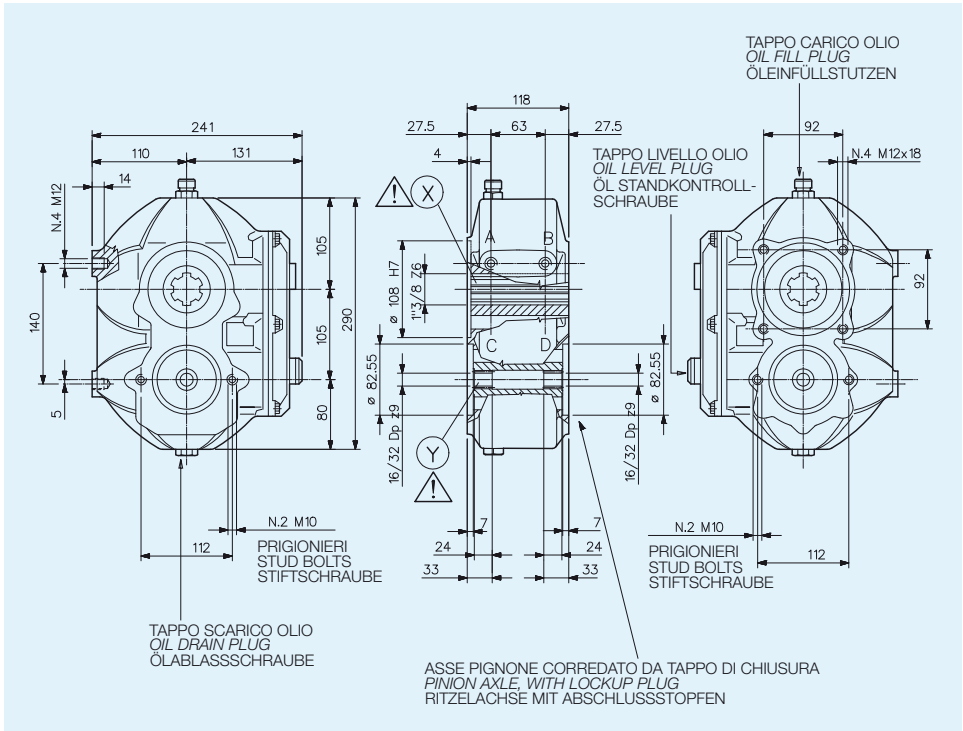

RAPPORTO RATIO VERHÄLTNIS	INGRESSO INPUT EINGANG			USCITA OUTPUT AUSGANG		MONTAGGIO ARRANGEMENT MONTAGE	ENTRATA INPUT EINGANG	CODICE CODE BESTELLNUMMER
	min ⁻¹	POTENZA POWER LEISTUNG CV	POTENZA POWER LEISTUNG kW	COPPIA TORQUE DREHM. N-m	COPPIA TORQUE DREHM. N-m			
1:2,5	540	60	44	795	300	1350	X	6005.360.025
1:3,5					220	1927		6005.360.035
1:4					196	2160		6005.360.040

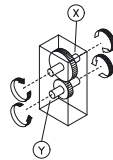

PESO INDICATIVO APPROXIMATE WEIGHT GEWICHT CA.	OLIO CONSIGLIATO RECOMMENDED OIL EMPFOHLENES ÖL	MATERIALI MATERIALS WERKSTOFF			CUSCINETTI BEARINGS NADELLAGER				
		SCATOLA CASE GEHAUSE	ALBERI SHAFTS WELLEN	INGRANAGGI GEARS VERZÄHNUNG	A	B	C	D	E
Kg.	SAE 90 Kg.	G 25	20MnCr5	20MnCr5	6210	6210	6208	6208	

SCATOLE PER POMPE OLEODINAMICHE GEARBOX FOR HYDRAULIC GEAR PUMPS GETRIEBE FÜR ÖLKRAFTZAHNRADERPUMPEN

M7

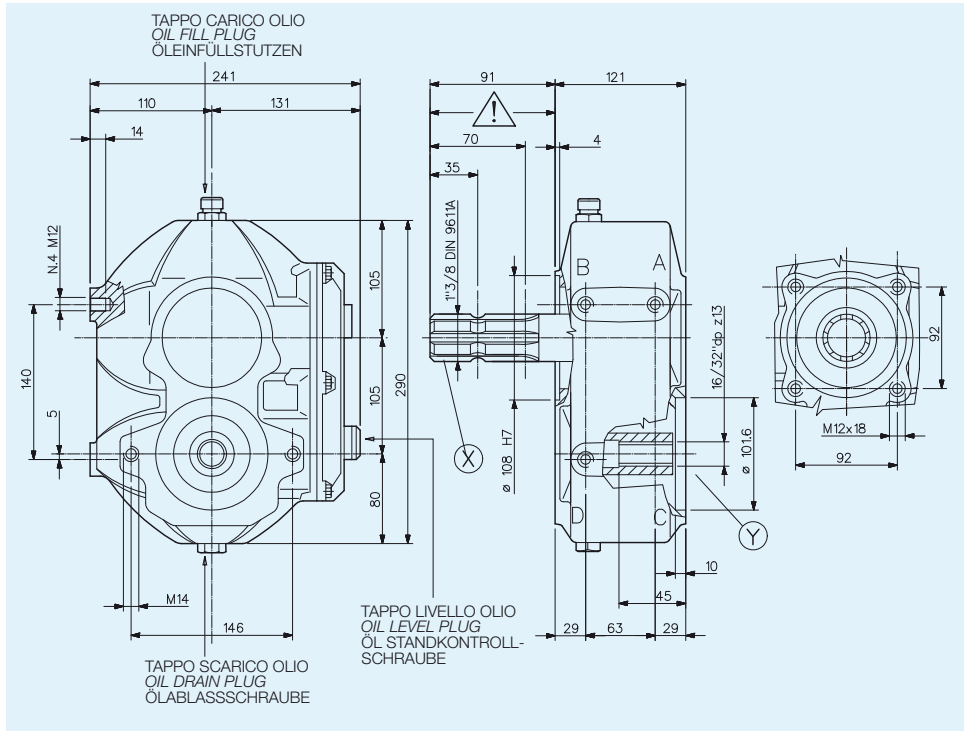

RAPPORTO RATIO VERHÄLTNIS	INGRESSO INPUT EINGANG			USCITA OUTPUT AUSGANG		MONTAGGIO ARRANGEMENT MONTAGE	ENTRATA INPUT EINGANG	CODICE CODE BESTELLNUMMER
	min ⁻¹	POTENZA POWER LEISTUNG CV	kW	COPPIA TORQUE DREHM. N-m	COPPIA TORQUE DREHM. N-m			
1:2	540	70	51.5	928	482	1026	X	6005.377.020
1:2,5	540	60	44	795	310	1350	X	6005.377.025
1:3	540	60	44	795	256	1620	X	6005.377.030
1:3,57	540	60	44	795	214	1928	X	6005.377.035
1:4	540	60	44	795	195	2160	X	6005.377.040
1:5	540	60	44	795	153	2700	X	6005.377.050

PESO INDICATIVO APPROXIMATE WEIGHT GEWICHT CA.	OLIO CONSIGLIATO RECOMMENDED OIL EMPFOHLENES ÖL	MATERIALI MATERIALS WERKSTOFF			CUSCINETTI BEARINGS NADELLAGER				
		SCATOLA CASE GEHAUSE	ALBERI SHAFTS WELLEN	INGRANAGGI GEARS VERZÄHNUNG	A	B	C	D	E
Kg.	SAE 90 Kg.								
21	2	G 25	20MnCr5	20MnCr5	6210	6210	6208	6208	

SCATOLE PER POMPE OLEODINAMICHE GEARBOX FOR HYDRAULIC GEAR PUMPS GETRIEBE FÜR ÖLKRAFTZAHNRADERPUMPEN

M7

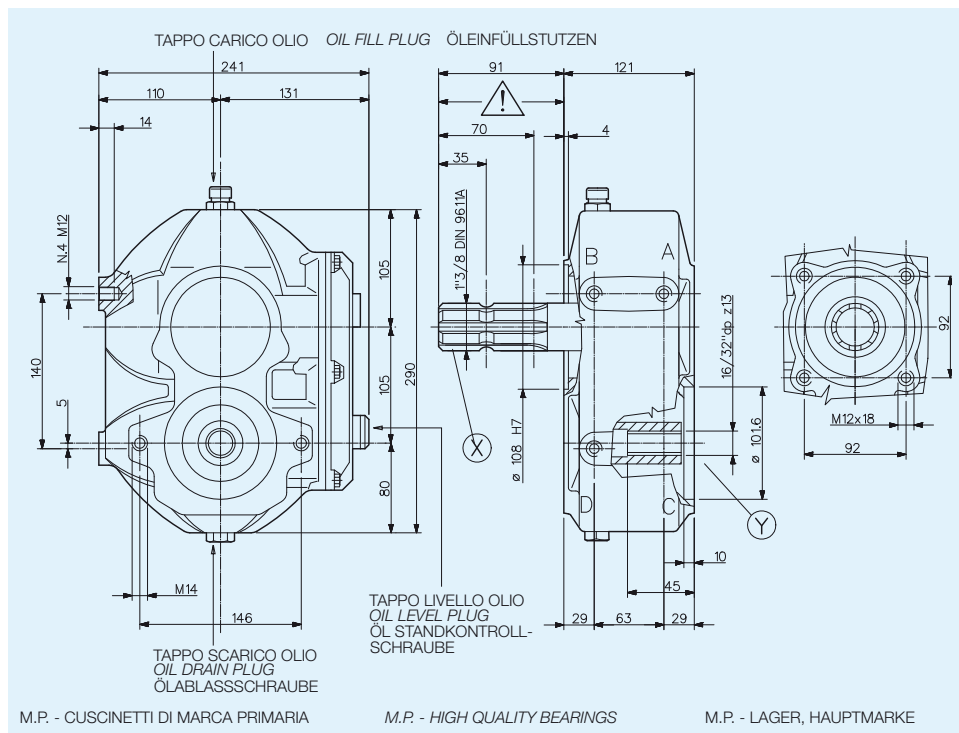

RAPPORTO RATIO VERHÄLTNIS	INGRESSO INPUT EINGANG		USCITA OUTPUT AUSGANG		MONTAGGIO ARRANGEMENT MONTAGE	ENTRATA INPUT EINGANG	CODICE CODE BESTELLNUMMER
	min ⁻¹	POTENZA POWER LEISTUNG CV kW	COPPIA TORQUE DREHM. N-m	COPPIA TORQUE DREHM. N-m			
1:2	540	70 51.5	928	482	1026	X	6005.378.020
1:2,5	540	60 44	795	310	1350	X	6005.378.025
1:3	540	60 44	795	256	1620	X	6005.378.030
1:3,57	540	60 44	795	214	1928	X	6005.378.035
1:4	540	60 44	795	195	2160	X	6005.378.040
1:5	540	60 44	795	153	2700	X	6005.378.050

PESO INDICATIVO APPROXIMATE WEIGHT GEWICHT CA.	OLIO CONSIGLIATO RECOMMENDED OIL EMPFOHLENES ÖL	MATERIALI MATERIALS WERKSTOFF			CUSCINETTI BEARINGS NADELLAGER				
		SCATOLA CASE GEHAUSE	ALBERI SHAFTS WELLEN	INGRANAGGI GEARS VERZÄHNUNG	A	B	C	D	E
Kg.	SAE 90 Kg.	G 25	20MnCr5	20MnCr5	6210 MP	6210 MP	6208 MP	6208 MP	
21	2	G 25	20MnCr5	20MnCr5	6210 MP	6210 MP	6208 MP	6208 MP	

SCATOLE PER POMPE OLEODINAMICHE GEARBOX FOR HYDRAULIC GEAR PUMPS GETRIEBE FÜR ÖLKRAFTZAHNRADERPUMPEN

M7

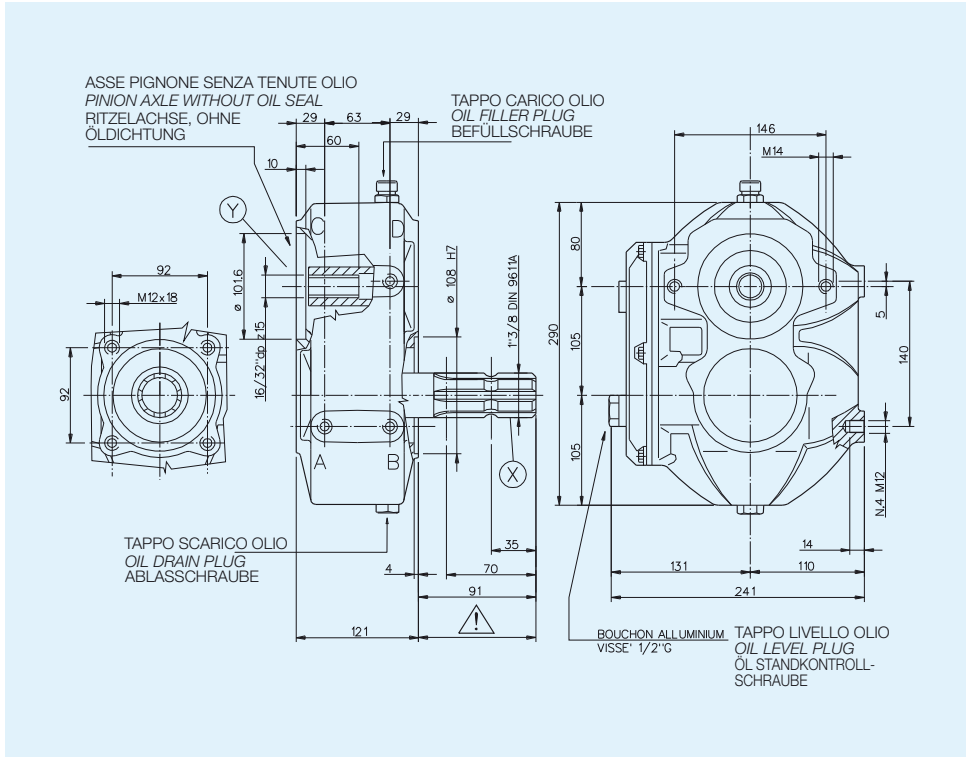

RAPPORTO RATIO VERHALTNIS	ENTRATA INPUT EINGANG		USCITA OUTPUT AUSGANG			MONTAGGIO ARRANGEMENT MONTAGE	ENTRATA INPUT EINGANG	CODICE CODE BESTELLNUMMER
	giri/min r.p.m. U/min. min ⁻¹	POTENZA POWER LEISTUNG CV kW	COPPIA TORQUE DREHEM N·m	COPPIA TORQUE DREHEM N·m	giri/min r.p.m. U/min. min ⁻¹			
1:1.93	540	70 51.5	928	482	1026		X	6005.324.020
1:2.50	540	60 44	795	310	1350		X	6005.324.025
1:3.04	540	60 44	795	256	1620		X	6005.324.030
1:3.57	540	60 44	795	214	1928		X	6005.324.035
1:4.00	540	60 44	795	195	2160		X	6005.324.040
1:5.06	540	60 44	795	153	2700		X	6005.324.050

PESO INDICATIVO APPROXIMATE WEIGHT GEWICHT CA.	OLIO CONSIGLIATO RECOMMENDED OIL EMPFOHLENES ÖL	MATERIALI MATERIALS WERKSTOFF			CUSCINETTI BEARINGS NADELLAGER				
		SCATOLA CASE GEHAUSE	ALBERI SHAFTS WELLEN	INGRANAGGI GEARS VERZÄHNUNG	A	B	C	D	E
kg									
21	SAE 90 kg 1.2	G 25	20MnCr5	20MnCr5	6210	6210	6208	6208	

SCATOLE PER POMPE OLEODINAMICHE GEARBOX FOR HYDRAULIC GEAR PUMPS GETRIEBE FÜR ÖLKRAFTZAHNRADERPUMPEN

M7

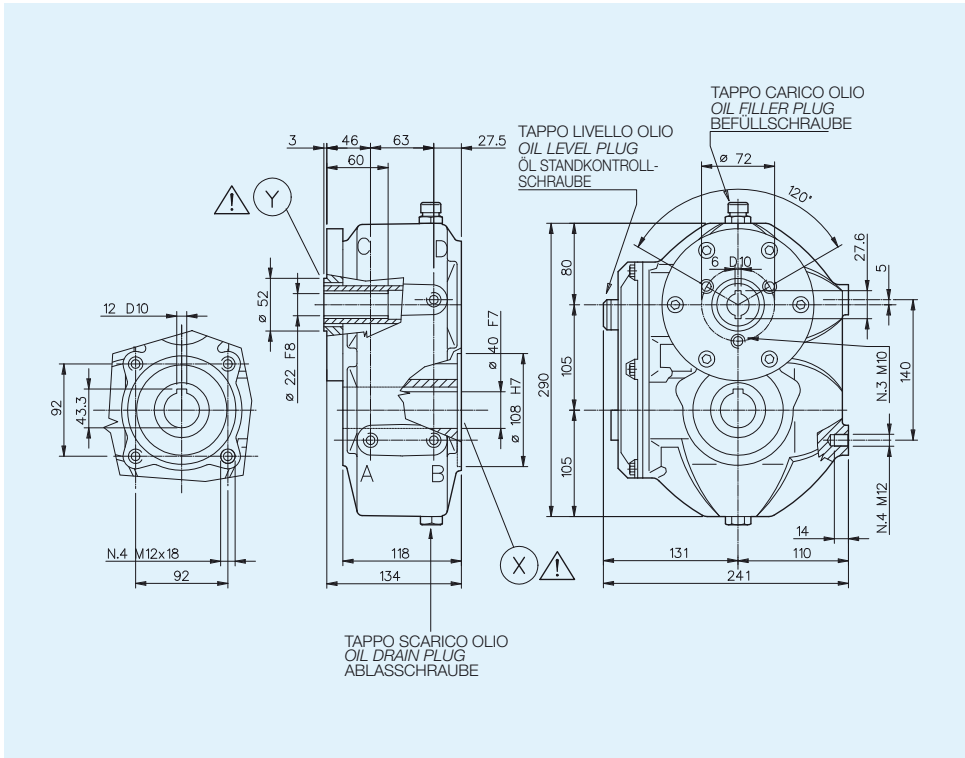

RAPPORTO RATIO VERHÄLTNIS	ENTRATA INPUT EINGANG		USCITA OUTPUT AUSGANG			MONTAGGIO ARRANGEMENT MONTAGE	ENTRATA INPUT EINGANG	CODICE CODE BESTELLNUMMER
	giri/min r.p.m. U/min. min ⁻¹	POTENZA POWER LEISTUNG CV kW	COPPIA TORQUE DREHEM N·m	COPPIA TORQUE DREHEM N·m	giri/min r.p.m. U/min. min ⁻¹			
1:1	540	70 51.5	928	910	540		X	6005.351.010

PESO INDICATIVO APPROXIMATE WEIGHT GEWICHT CA.	OLIO CONSIGLIATO RECOMMENDED OIL EMPFOHLENES ÖL	MATERIALI MATERIALS WERKSTOFF			CUSCINETTI BEARINGS NADELLAGER					
		SCATOLA CASE GEHAUSE	ALBERI SHAFTS WELLEN	INGRANAGGI GEARS VERZÄHNUNG	A	B	C	D	E	
kg										
21	SAE 90 kg 2	G 25	20MnCr5	20MnCr5	6011	6011	6307	6307		

SCATOLE PER POMPE OLEODINAMICHE GEARBOX FOR HYDRAULIC GEAR PUMPS GETRIEBE FÜR ÖLKRAFTZAHNRADERPUMPEN

M7

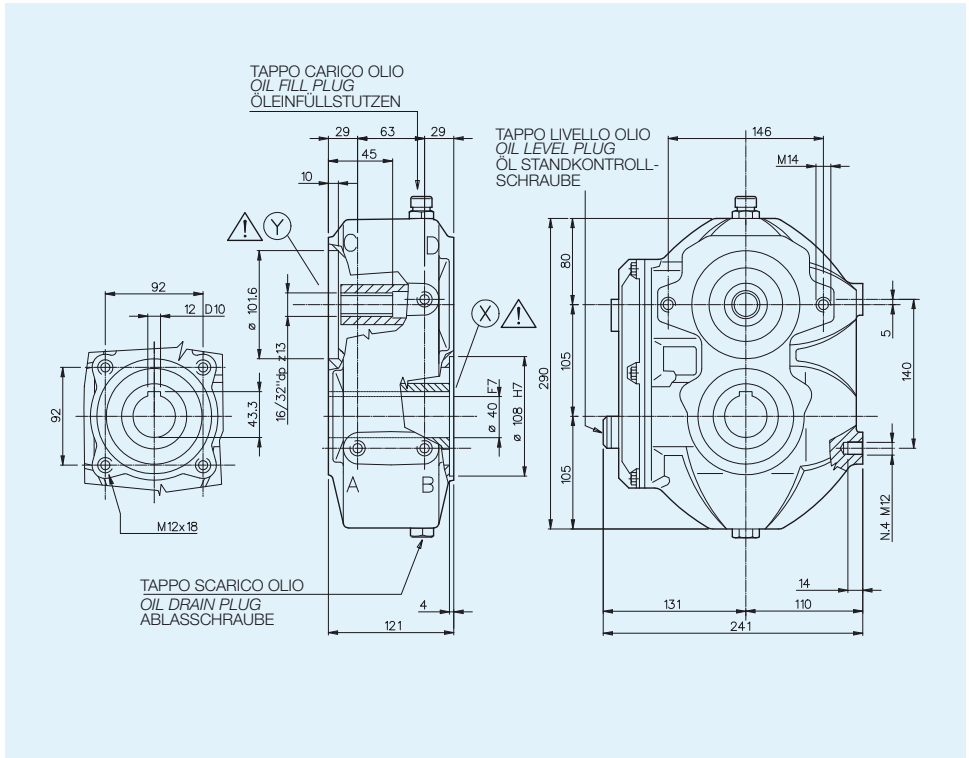

RAPPORTO RATIO VERHÄLTNIS	ENTRATA INPUT EINGANG		USCITA OUTPUT AUSGANG		MONTAGGIO ARRANGEMENT MONTAGE	ENTRATA INPUT EINGANG	CODICE CODE BESTELLNUMMER
	giri/min r.p.m. U/min. min ⁻¹	POTENZA POWER LEISTUNG CV kW	COPPIA TORQUE DREHEM N·m	COPPIA TORQUE DREHEM N·m			
1:1.9	540	70 51.5	928	480		X	6005.353.019
1:2.5	540	60 44	795	310		X	6005.353.025
1:3	540	60 44	795	256		X	6005.353.030
1:3.57	540	60 44	795	214		X	6005.353.035
1:4	540	60 44	795	195		X	6005.353.040
1:5	540	60 44	795	153		X	6005.353.050

PESO INDICATIVO APPROXIMATE WEIGHT GEWICHT CA.	OLIO CONSIGLIATO RECOMMENDED OIL EMPFOHLENES ÖL	MATERIALI MATERIALS WERKSTOFF			CUSCINETTI BEARINGS NADELLAGER				
		SCATOLA CASE GEHAUSE	ALBERI SHAFTS WELLEN	INGRANAGGI GEARS VERZÄHNUNG	A	B	C	D	E
kg									
21	SAE 90 kg 1,2	G 25	20MnCr5	20MnCr5	6011	6011	6307	6307	

SCATOLE PER POMPE OLEODINAMICHE GEARBOX FOR HYDRAULIC GEAR PUMPS GETRIEBE FÜR ÖLKRAFTZAHNRADERPUMPEN

M7

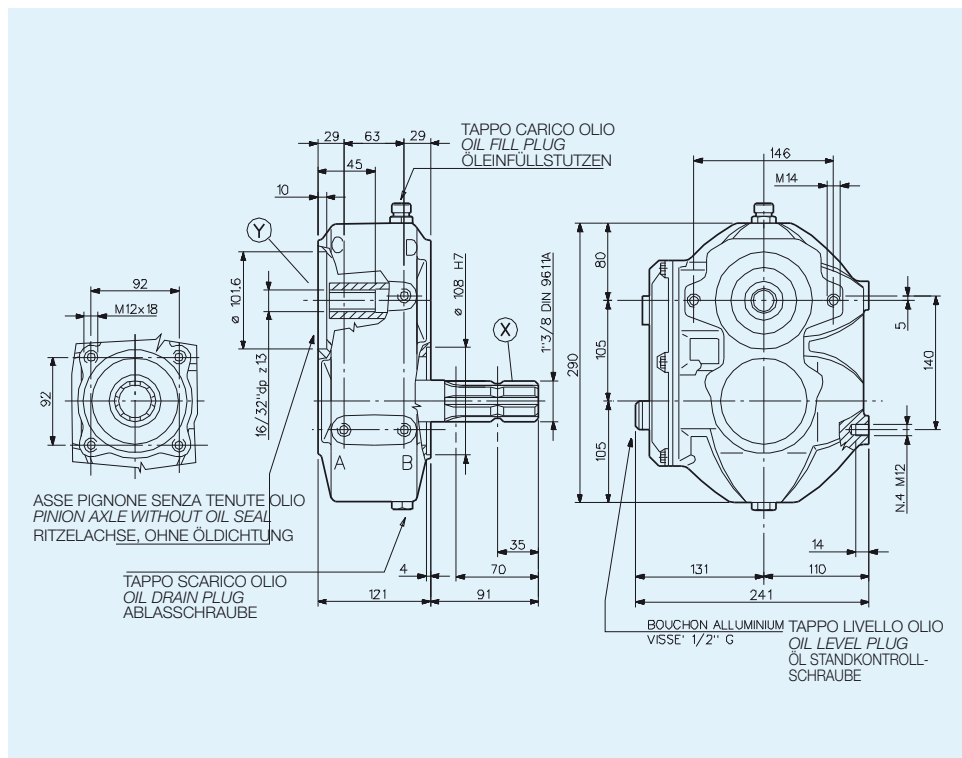

RAPPORTO RATIO VERHALTNIS	ENTRATA INPUT EINGANG		USCITA OUTPUT AUSGANG			MONTAGGIO ARRANGEMENT MONTAGE	ENTRATA INPUT EINGANG	CODICE CODE BESTELLNUMMER
	giri/min r.p.m. U/min. min ⁻¹	POTENZA POWER LEISTUNG CV kW	COPPIA TORQUE DREHEM N·m	COPPIA TORQUE DREHEM N·m	giri/min r.p.m. U/min. min ⁻¹			
1:2	540	70 51.5	928	482	1026		X	6005.361.020
1:2.5	540	60 44	795	310	1350		X	6005.361.025
1:3	540	60 44	795	256	1620		X	6005.361.030
1:3.57	540	60 44	795	214	1928		X	6005.361.035
1:4	540	60 44	795	195	2160		X	6005.361.040
1:5	540	60 44	795	153	2700		X	6005.361.050
1:7	200	31 23	1087	154	1400		X	6005.361.070
1:7	540	60 44	795	111	3780		X	6005.361.070

PESO INDICATIVO APPROXIMATE WEIGHT GEWICHT CA.	OLIO CONSIGLIATO RECOMMENDED OIL EMPFOHLENES ÖL	MATERIALI MATERIALS WERKSTOFF			CUSCINETTI BEARINGS NADELLAGER				
		SCATOLA CASE GEHAUSE	ALBERI SHAFTS WELLEN	INGRANAGGI GEARS VERZÄHNUNG	A	B	C	D	E
kg									
21	SAE 90 kg 1.2	G 25	20MnCr5	20MnCr5	6210	6210	6208	6208	

SCATOLE PER POMPE OLEODINAMICHE GEARBOX FOR HYDRAULIC GEAR PUMPS GETRIEBE FÜR ÖLKRAFTZAHNRADERPUMPEN

M7

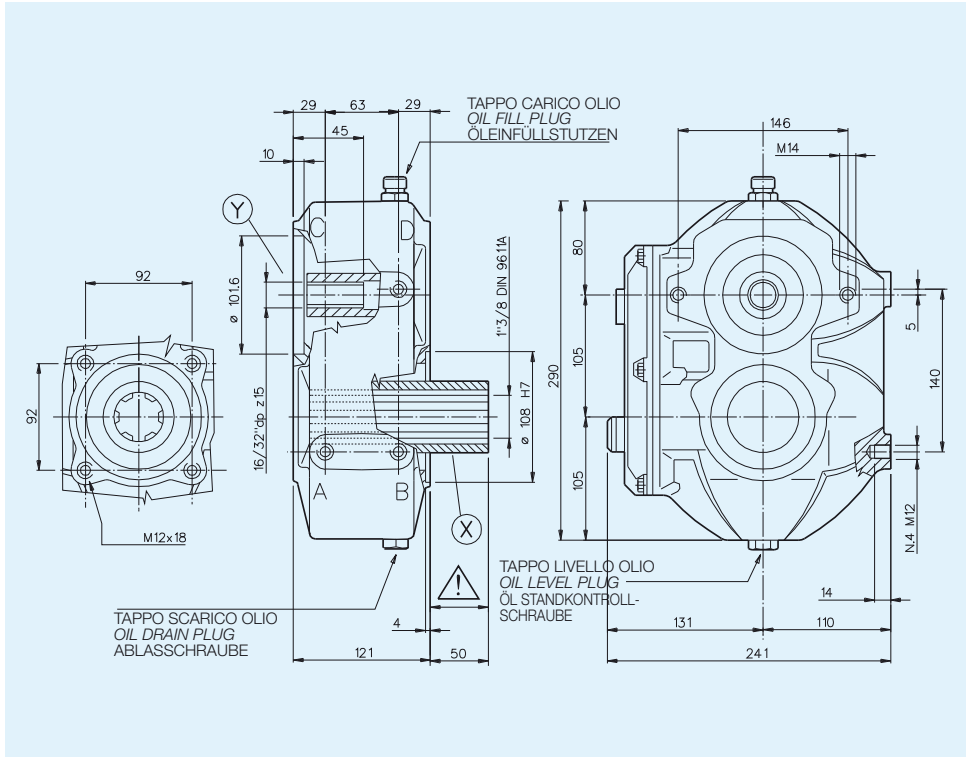

RAPPORTO RATIO VERHÄLTNIS	ENTRATA INPUT EINGANG		USCITA OUTPUT AUSGANG		MONTAGGIO ARRANGEMENT MONTAGE	ENTRATA INPUT EINGANG	CODICE CODE BESTELLNUMMER
	giri/min r.p.m. U/min. min ⁻¹	POTENZA POWER LEISTUNG CV kW	COPPIA TORQUE DREHEM N·m	COPPIA TORQUE DREHEM N·m			
1:2	1000	100 73.5	716	360		X	6005.363.020
1:2.5	540	60 44	795	310		X	6005.363.025
1:3	540	60 44	795	256		X	6005.363.030
1:3.5	540	60 44	795	214		X	6005.363.035
1:4	540	60 44	795	195		X	6005.363.040
1:4.5	540	56 41	742	161		X	6005.363.045
1:5	540	60 44	395	153		X	6005.363.050

PESO INDICATIVO APPROXIMATE WEIGHT GEWICHT CA.	OLIO CONSIGLIATO RECOMMENDED OIL EMPFOHLENES ÖL	MATERIALI MATERIALS WERKSTOFF			CUSCINETTI BEARINGS NADELLAGER				
		SCATOLA CASE GEHAUSE	ALBERI SHAFTS WELLEN	INGRANAGGI GEARS VERZÄHNUNG	A	B	C	D	E
kg									
21	SAE 90 kg 2	G 25	20MnCr5	20MnCr5	6210	6210	6208	6208	

SCATOLE PER POMPE OLEODINAMICHE GEARBOX FOR HYDRAULIC GEAR PUMPS GETRIEBE FÜR ÖLKRAFTZAHNRADERPUMPEN

M7

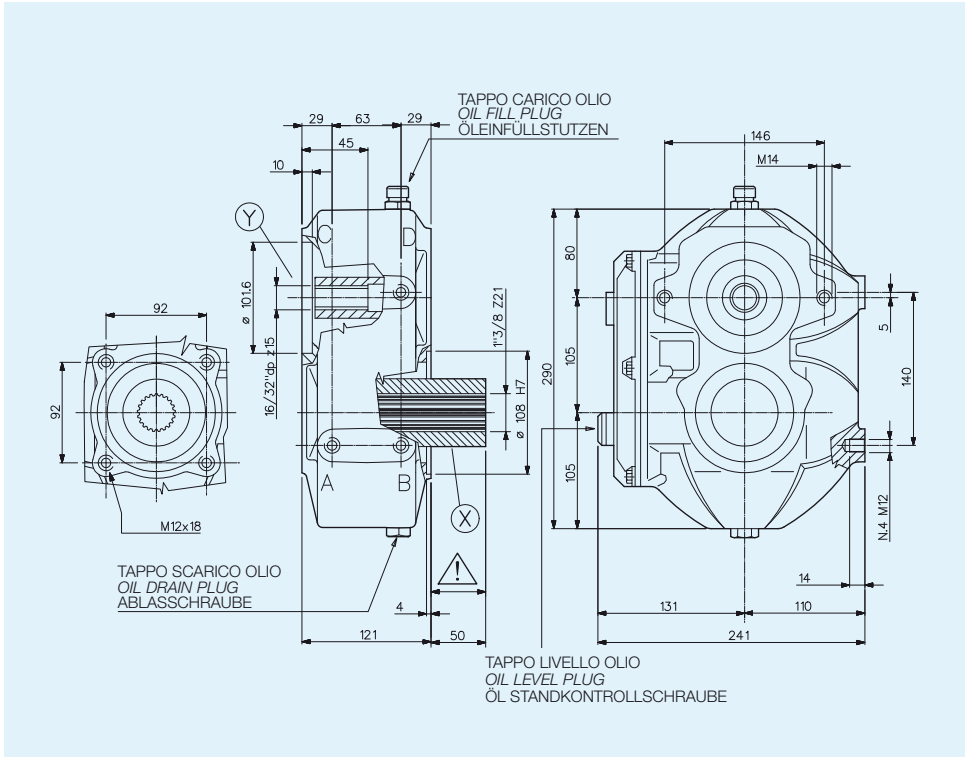

RAPPORTO RATIO VERHALTNIS	ENTRATA INPUT EINGANG		USCITA OUTPUT AUSGANG			MONTAGGIO ARRANGEMENT MONTAGE	ENTRATA INPUT EINGANG	CODICE CODE BESTELLNUMMER
	giri/min r.p.m. U/min. min ⁻¹	POTENZA POWER LEISTUNG CV kW	COPPIA TORQUE DREHEM N·m	COPPIA TORQUE DREHEM N·m	giri/min r.p.m. U/min. min ⁻¹			
1:2.5	540	60 44	795	310	1350		X	6005.385.025
1:3	540	60 44	795	256	1620		X	6005.385.030
1:3.5	540	60 44	795	214	1928		X	6005.385.035
1:4	540	60 44	795	195	2160		X	6005.385.040
1:4.5	540	56 41	742	161	2430		X	6005.385.045

PESO INDICATIVO APPROXIMATE WEIGHT GEWICHT CA.	OLIO CONSIGLIATO RECOMMENDED OIL EMPFOHLENES ÖL	MATERIALI MATERIALS WERKSTOFF			CUSCINETTI BEARINGS NADELLAGER				
		SCATOLA CASE GEHAUSE	ALBERI SHAFTS WELLEN	INGRANAGGI GEARS VERZÄHNUNG	A	B	C	D	E
kg									
21	SAE 90 kg 2	G 25	20MnCr5	20MnCr5	6210	6210	6307	6307	

SCATOLE PER POMPE OLEODINAMICHE GEARBOX FOR HYDRAULIC GEAR PUMPS GETRIEBE FÜR ÖLKRAFTZAHNRADERPUMPEN

M7

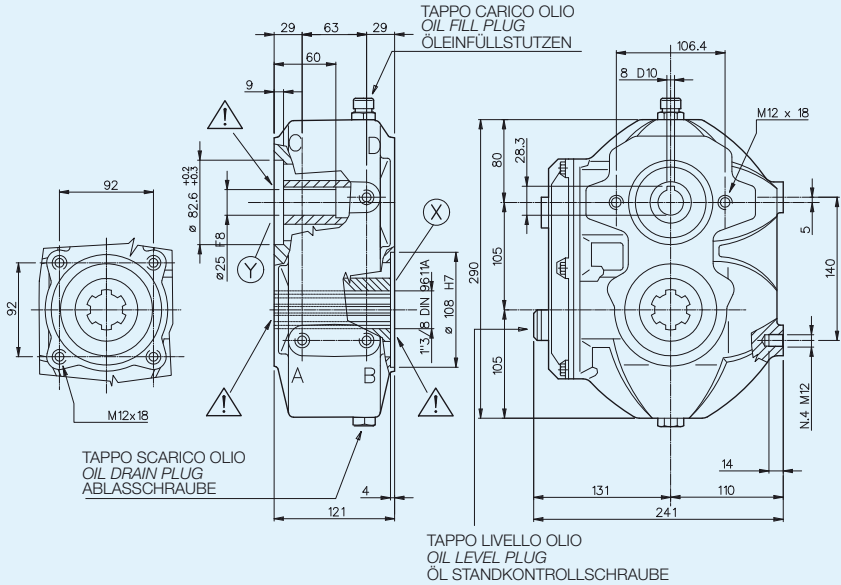

RAPPORTO RATIO VERHÄLTNIS	ENTRATA INPUT EINGANG		USCITA OUTPUT AUSGANG		MONTAGGIO ARRANGEMENT MONTAGE	ENTRATA INPUT EINGANG	CODICE CODE BESTELLNUMMER
	giri/min r.p.m. U/min. min ⁻¹	POTENZA POWER LEISTUNG CV kW	COPPIA TORQUE DREHEM N·m	COPPIA TORQUE DREHEM N·m			
4:1	300	10 7.3	234	900		Y	6005.388.040
1:4	540	60 44	795	195		X	6005.388.040

PESO INDICATIVO APPROXIMATE WEIGHT GEWICHT CA.	OLIO CONSIGLIATO RECOMMENDED OIL EMPFOHLENES ÖL	MATERIALI MATERIALS WERKSTOFF			CUSCINETTI BEARINGS NADELLAGER				
		SCATOLA CASE GEHAUSE	ALBERI SHAFTS WELLEN	INGRANAGGI GEARS VERZÄHNUNG	A	B	C	D	E
kg									
21	SAE 90 kg 2	G 25	20MnCr5	20MnCr5	6210	6210	6208	6208	

SCATOLE PER POMPE OLEODINAMICHE GEARBOX FOR HYDRAULIC GEAR PUMPS GETRIEBE FÜR ÖLKRAFTZAHNRADERPUMPEN

M7

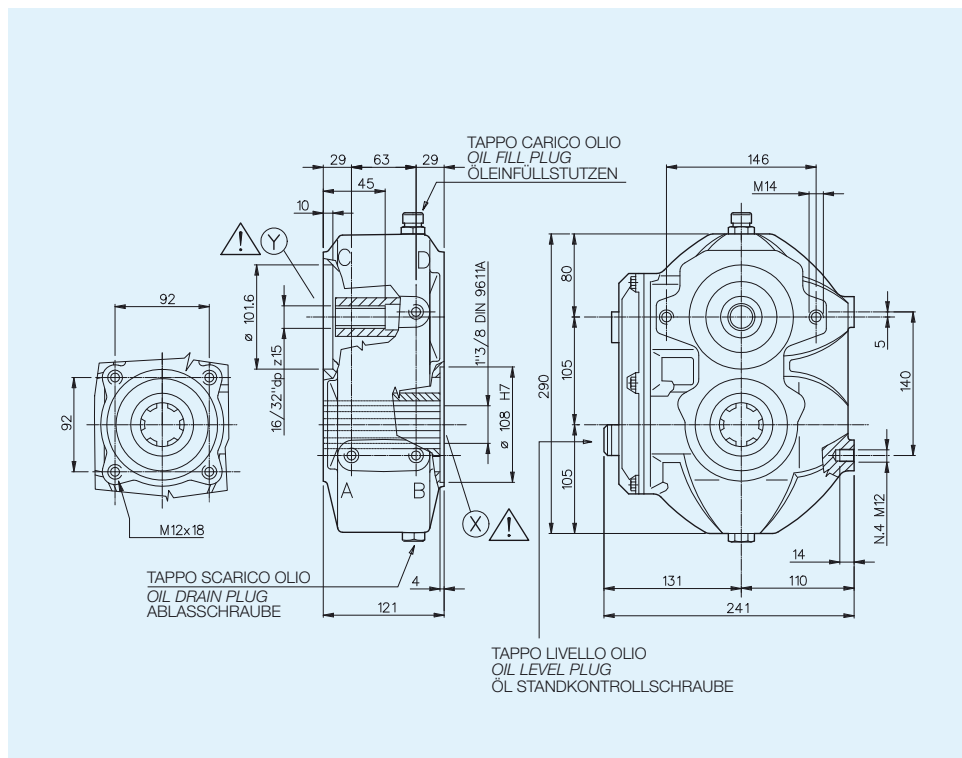

RAPPORTO RATIO VERHÄLTNIS	ENTRATA INPUT EINGANG		USCITA OUTPUT AUSGANG			MONTAGGIO ARRANGEMENT MONTAGE	ENTRATA INPUT EINGANG	CODICE CODE BESTELLNUMMER
	giri/min r.p.m. U/min. min ⁻¹	POTENZA POWER LEISTUNG CV kW	COPPIA TORQUE DREHEM N·m	COPPIA TORQUE DREHEM N·m	giri/min r.p.m. U/min. min ⁻¹			
1:2.5	540	60 44	795	300	1350		X	6005.393.025
1:3	540	60 44	795	256	1620		X	6005.393.030
1:3.5	540	60 44	795	214	1928		X	6005.393.035
1:4	540	60 44	795	190	2160		X	6005.393.040
1:5	540	60 44	795	153	2700		X	6005.393.050

PESO INDICATIVO APPROXIMATE WEIGHT GEWICHT CA.	OLIO CONSIGLIATO RECOMMENDED OIL EMPFOHLENES ÖL	MATERIALI MATERIALS WERKSTOFF			CUSCINETTI BEARINGS NADELLAGER					
		SCATOLA CASE GEHAUSE	ALBERI SHAFTS WELLEN	INGRANAGGI GEARS VERZÄHNUNG	A	B	C	D	E	
kg										
21	SAE 90 kg 2	G 25	20MnCr5	20MnCr5	6210	6210	6208	6208		

SCATOLE PER POMPE OLEODINAMICHE GEARBOX FOR HYDRAULIC GEAR PUMPS GETRIEBE FÜR ÖLKRAFTZAHNRADERPUMPEN

M7

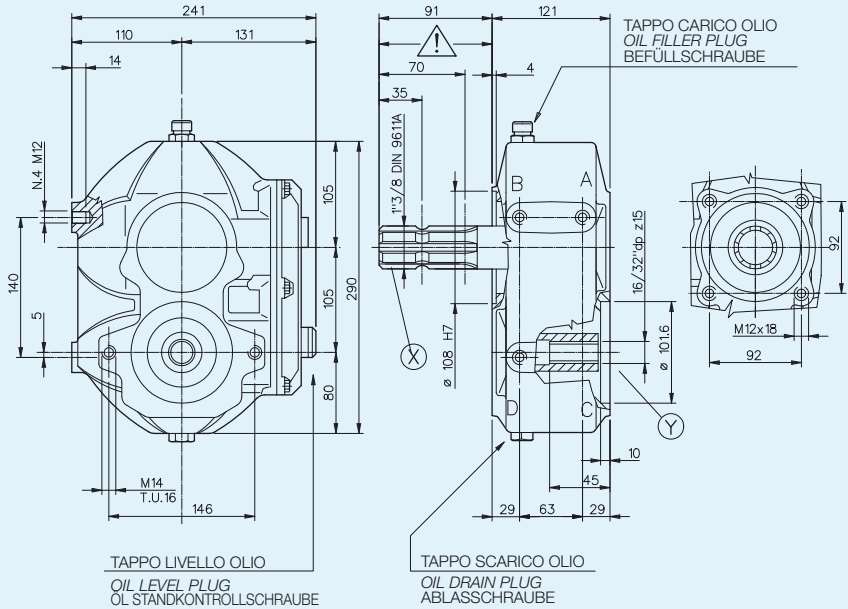

RAPPORTO RATIO VERHALTNIS	ENTRATA INPUT EINGANG		USCITA OUTPUT AUSGANG		MONTAGGIO ARRANGEMENT MONTAGE	ENTRATA INPUT EINGANG	CODICE CODE BESTELLNUMMER
	giri/min r.p.m. U/min. min ⁻¹	POTENZA POWER LEISTUNG CV kW	COPPIA TORQUE DREHEM N·m	COPPIA TORQUE DREHEM N·m			
1:2	540	70 51.5	928	482	1026	X	6005.401.020
1:2.5	540	60 44	795	310	1350	X	6005.401.025
1:3	540	60 44	795	256	1620	X	6005.401.030
1:3.57	540	60 44	795	214	1928	X	6005.401.035
1:4	540	60 44	795	195	2160	X	6005.401.040
1:5	540	60 44	795	153	2700	X	6005.401.050

PESO INDICATIVO APPROXIMATE WEIGHT GEWICHT CA.	OLIO CONSIGLIATO RECOMMENDED OIL EMPFOHLENES ÖL	MATERIALI MATERIALS WERKSTOFF			CUSCINETTI BEARINGS NADELLAGER				
		SCATOLA CASE GEHAUSE	ALBERI SHAFTS WELLEN	INGRANAGGI GEARS VERZÄHNUNG	A	B	C	D	E
kg									
21	SAE 90 kg 1,2	G 25	20MnCr5	20MnCr5	6210	6210	6208	6208	

SCATOLE PER POMPE OLEODINAMICHE GEARBOX FOR HYDRAULIC GEAR PUMPS GETRIEBE FÜR ÖLKRAFTZAHNRADERPUMPEN

MPD

(*) TAPPO OLIO 1/2" G

(*) 1/2" G OIL PLUG

(*) VERSCHLUSSSCHRAUBE 1/2" G

(**) TAPPO OLIO CILINDRICO 1/2" G

(**) 1/2" G CYLINDRICAL OIL PLUG

(**) VERSCHLUSSSCHRAUBE 1/2" G ZYLINDRISCH

(***) TAPPO CARICO OLIO 1/2" G

(***) 1/2" G OIL FILLER PLUG

(***) ÖLEINFÜLLSCHRAUBE 1/2" G

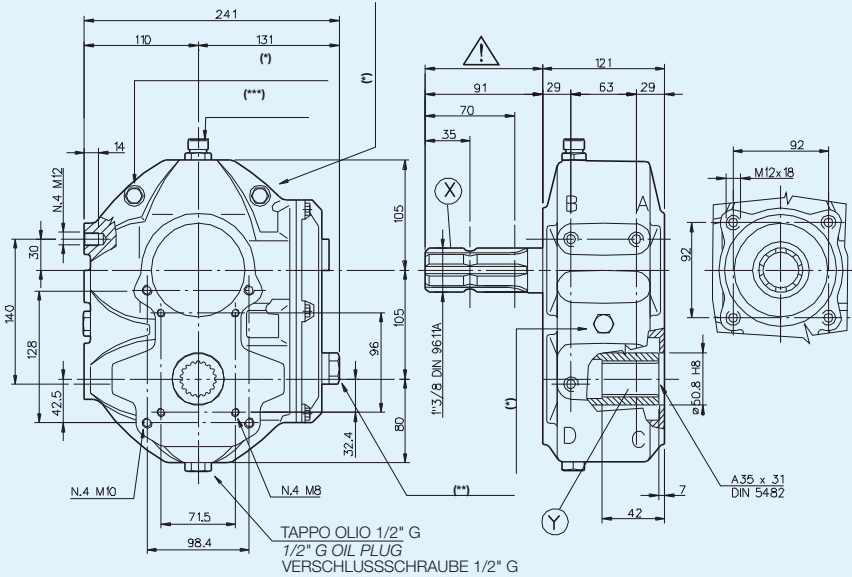

RAPPORTO RATIO VERHÄLTNIS	ENTRATA INPUT EINGANG		USCITA OUTPUT AUSGANG			MONTAGGIO ARRANGEMENT MONTAGE	ENTRATA INPUT EINGANG	CODICE CODE BESTELLNUMMER
	giri/min r.p.m. U/min. min ⁻¹	POTENZA POWER LEISTUNG CV kW	COPPIA TORQUE DREHEM N·m	COPPIA TORQUE DREHEM N·m	giri/min r.p.m. U/min. min ⁻¹			
1:3	540	60 44	795	254	1620		X	6071.310.030
1:3.57	540	60 44	795	214	1928		X	6071.310.035

PESO INDICATIVO APPROXIMATE WEIGHT GEWICHT CA.	OLIO CONSIGLIATO RECOMMENDED OIL EMPFOHLENES ÖL	MATERIALI MATERIALS WERKSTOFF			CUSCINETTI BEARINGS NADELLAGER				
		SCATOLA CASE GEHAUSE	ALBERI SHAFTS WELLEN	INGRANAGGI GEARS VERZÄHNUNG	A	B	C	D	E
kg									
21	ISO VG 150-320 lt 1,2	G 25	20MnCr5	20MnCr5	6210	6210	32010	32010	

SCATOLE PER POMPE OLEODINAMICHE GEARBOX FOR HYDRAULIC GEAR PUMPS GETRIEBE FÜR ÖLKRAFTZAHNRADERPUMPEN

MPD

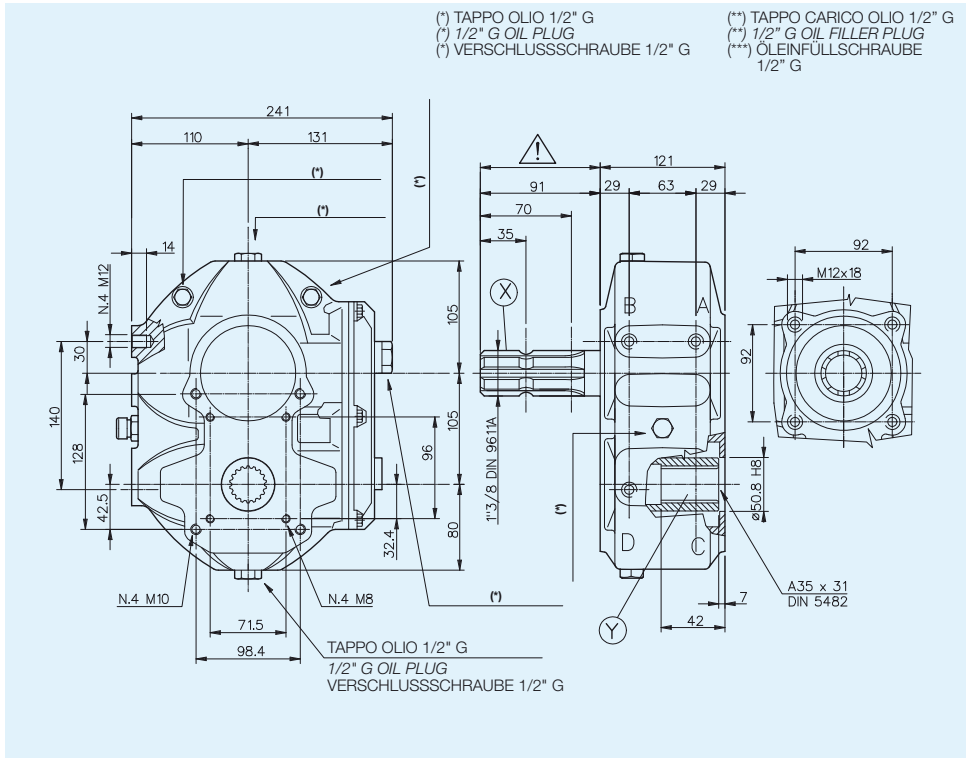

RAPPORTO RATIO VERHÄLTNIS	ENTRATA INPUT EINGANG		USCITA OUTPUT AUSGANG		MONTAGGIO ARRANGEMENT MONTAGE	ENTRATA INPUT EINGANG	CODICE CODE BESTELLNUMMER
	giri/min r.p.m. U/min. min ⁻¹	POTENZA POWER LEISTUNG CV kW	COPPIA TORQUE DREHEM N·m	COPPIA TORQUE DREHEM N·m			
1:3.57	540	60 44	795	220	1927	X	6071.311.035

PESO INDICATIVO APPROXIMATE WEIGHT GEWICHT CA.	OLIO CONSIGLIATO RECOMMENDED OIL EMPFOHLENES ÖL	MATERIALI MATERIALS WERKSTOFF			CUSCINETTI BEARINGS NADELLAGER				
		SCATOLA CASE GEHAUSE	ALBERI SHAFTS WELLEN	INGRANAGGI GEARS VERZÄHNUNG	A	B	C	D	E
kg	ISO VG150-320 LT. 1.2	G 25	20MnCr5	20MnCr5	6210	6210	32010	32010	
21	SAE 90 kg 1	G 25	20MnCr5	20MnCr5	6210	6210	32010	32010	

SCATOLE PER POMPE OLEODINAMICHE GEARBOX FOR HYDRAULIC GEAR PUMPS GETRIEBE FÜR ÖLKRAFTZAHNRADERPUMPEN

MPD

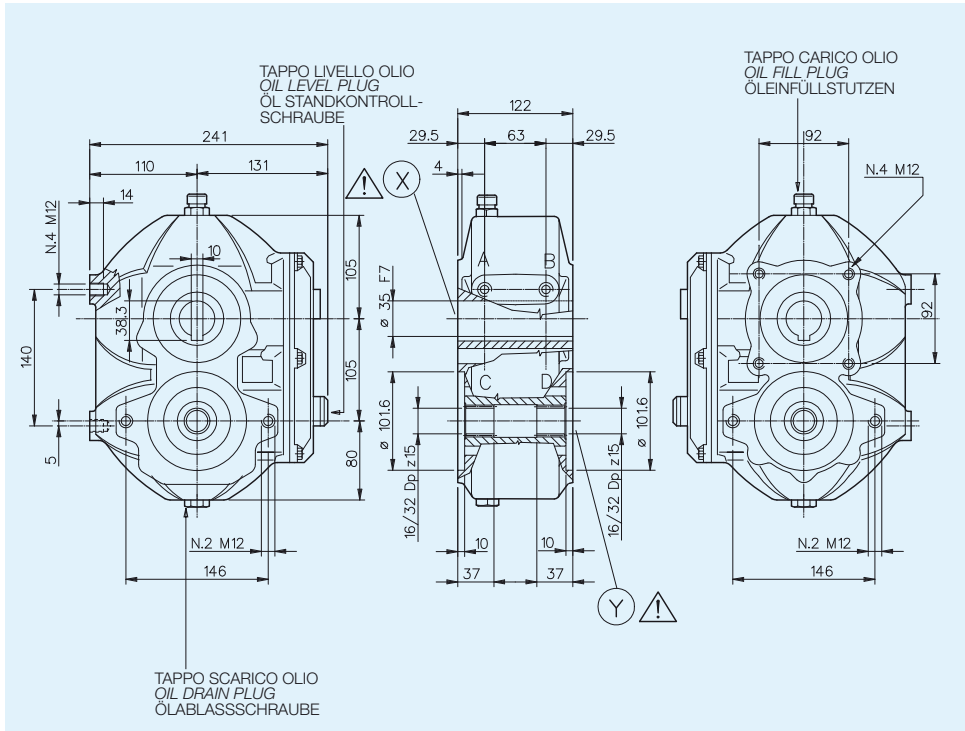

RAPPORTO RATIO VERHÄLTNIS	INGRESSO INPUT EINGANG		USCITA OUTPUT AUSGANG		MONTAGGIO ARRANGEMENT MONTAGE	ENTRATA INPUT EINGANG	CODICE CODE BESTELLNUMMER
	min ⁻¹	POTENZA POWER LEISTUNG CV kW	COPPIA TORQUE DREHM. N·m	COPPIA TORQUE DREHM. N·m			
1:25	1000	110 81	773	310	2500	X	6071.001.025

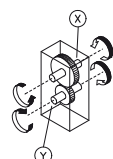

PESO INDICATIVO APPROXIMATE WEIGHT GEWICHT CA.	OLIO CONSIGLIATO RECOMMENDED OIL EMPFOHLENES ÖL	MATERIALI MATERIALS WERKSTOFF			CUSCINETTI BEARINGS NADELLAGER				
		SCATOLA CASE GEHAUSE	ALBERI SHAFTS WELLEN	INGRANAGGI GEARS VERZÄHNUNG	A	B	C	D	E
Kg. 21	SAE 90 Kg.	G 25	20MnCr5	20MnCr5	30210	30210	30208	30208	

SCATOLE PER POMPE OLEODINAMICHE GEARBOX FOR HYDRAULIC GEAR PUMPS GETRIEBE FÜR ÖLKRAFTZAHNRADERPUMPEN

MPD

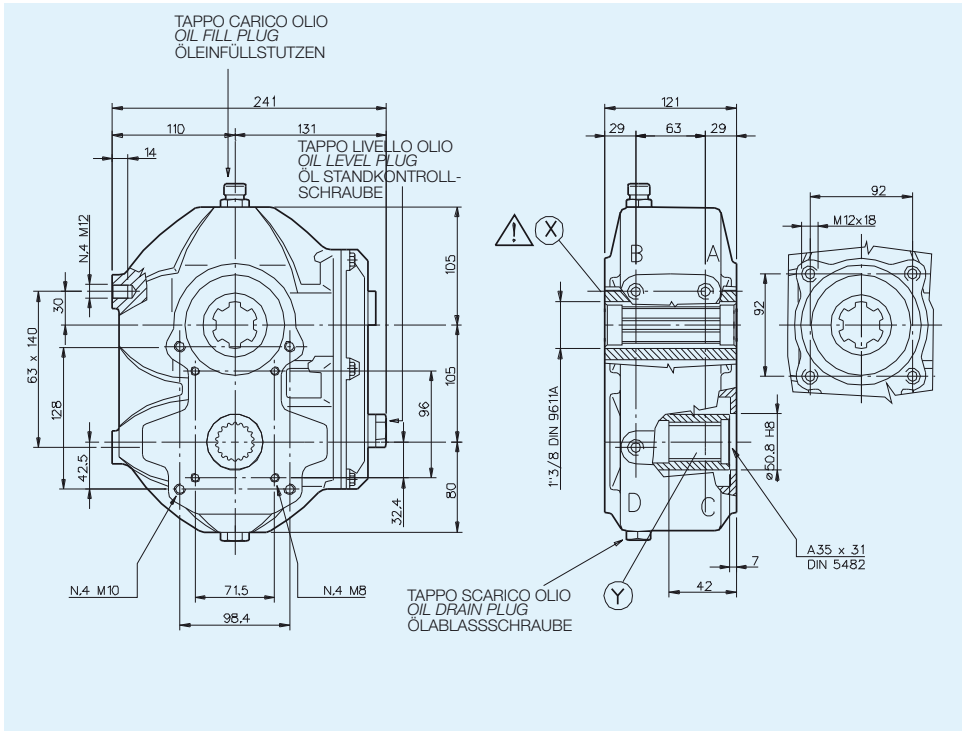

RAPPORTO RATIO VERHÄLTNIS	INGRESSO INPUT EINGANG			COPPIA TORQUE DREHM. N-m	COPPIA TORQUE DREHM. N-m	min ⁻¹	MONTAGGIO ARRANGEMENT MONTAGE	ENTRATA INPUT EINGANG	CODICE CODE BESTELLNUMMER
	min ⁻¹	POTENZA POWER LEISTUNG CV	POTENZA POWER LEISTUNG kW						
1:3,57	540	60	44	795	214	1928		X	6071.303.035

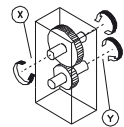

PESO INDICATIVO APPROXIMATE WEIGHT GEWICHT CA. Kg.	OLIO CONSIGLIATO RECOMMENDED OIL EMPFOHLENEES ÖL SAE 90 Kg.	SCATOLA CASE GEHAUSE G 25	MATERIALI MATERIALS WERKSTOFF			CUSCINETTI BEARINGS NADELLAGER				
			ALBERI SHAFTS WELLEN 20MnCr5	INGRANAGGI GEARS VERZÄHNUNG 20MnCr5	A	B	C	D	E	
21	2	G 25	20MnCr5	20MnCr5	6210	6210	32010	32010		

SCATOLE PER POMPE OLEODINAMICHE GEARBOX FOR HYDRAULIC GEAR PUMPS GETRIEBE FÜR ÖLKRAFTZAHNRADERPUMPEN

REG

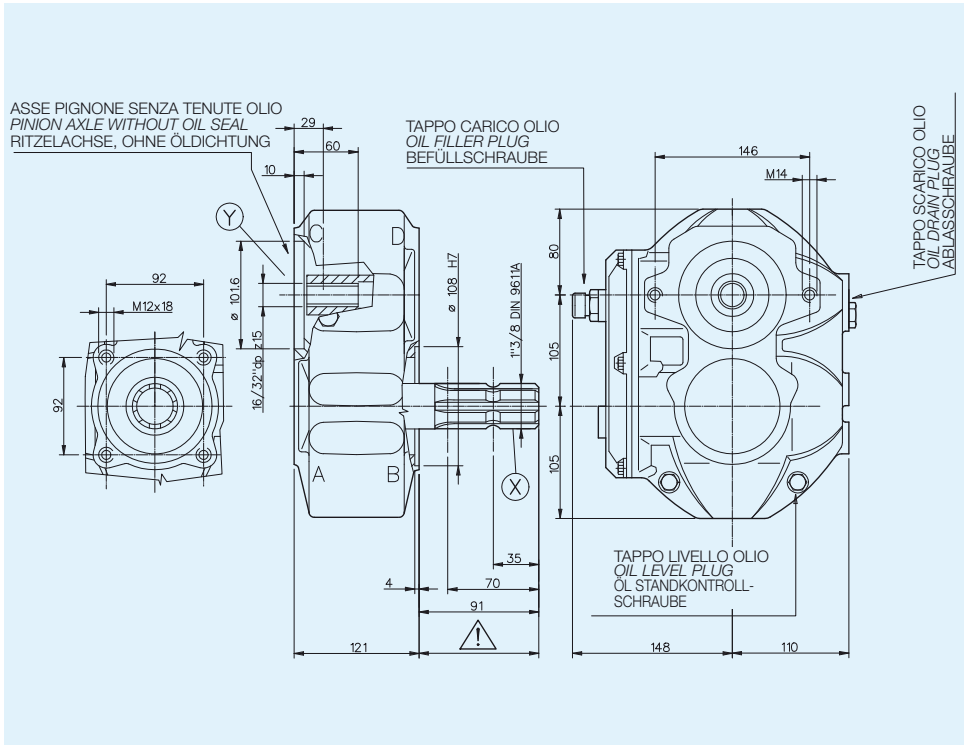

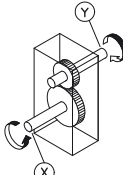
RAPPORTO RATIO VERHALTNIS	ENTRATA INPUT EINGANG		USCITA OUTPUT AUSGANG			MONTAGGIO ARRANGEMENT MONTAGE	ENTRATA INPUT EINGANG	CODICE CODE BESTELLNUMMER
	giri/min r.p.m. U/min. min ⁻¹	POTENZA POWER LEISTUNG CV kW	COPPIA TORQUE DREHEM N·m	COPPIA TORQUE DREHEM N·m	giri/min r.p.m. U/min. min ⁻¹			
1:3	540	60 44	795	256	1620		X	6065.302.030
1:3.57	540	60 44	795	214	1928		X	6065.302.035

PESO INDICATIVO APPROXIMATE WEIGHT GEWICHT CA.	OLIO CONSIGLIATO RECOMMENDED OIL EMPFOHLENES ÖL	MATERIALI MATERIALS WERKSTOFF			CUSCINETTI BEARINGS NADELLAGER				
		SCATOLA CASE GEHAUSE	ALBERI SHAFTS WELLEN	INGRANAGGI GEARS VERZÄHNUNG	A	B	C	D	E
kg									
21	SAE 90 kg 1	G 25	20MnCr5	20MnCr5	6210	6210	6208	6208	

SCATOLE PER POMPE OLEODINAMICHE GEARBOX FOR HYDRAULIC GEAR PUMPS GETRIEBE FÜR ÖLKRAFTZAHNRADERPUMPEN

REG

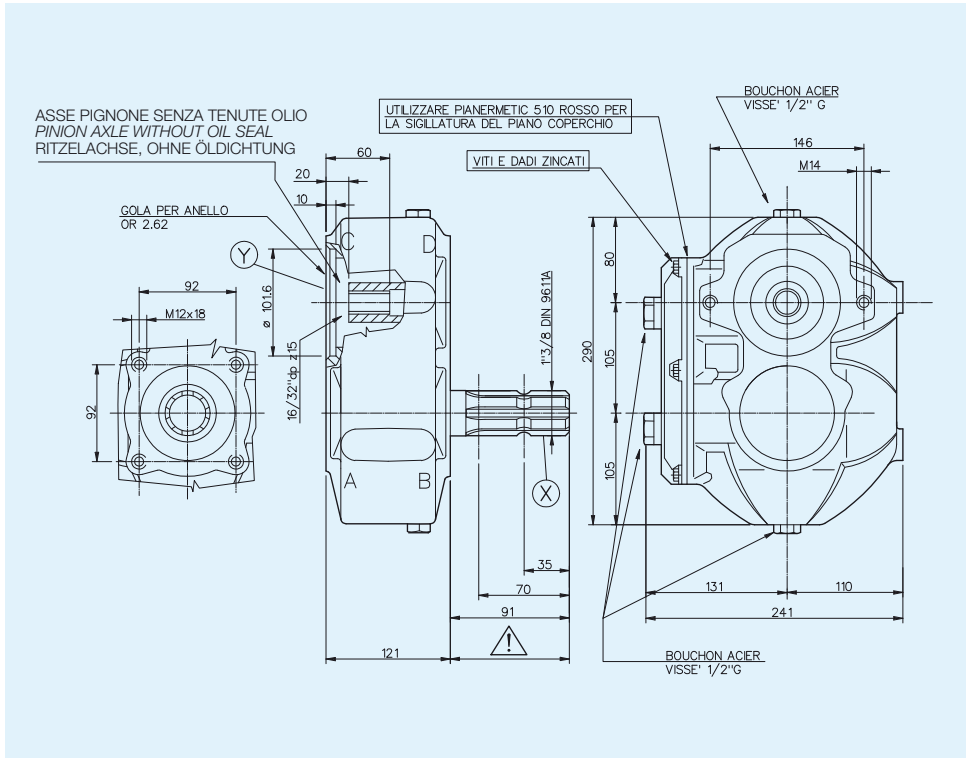

RAPPORTO RATIO VERHALTNIS	ENTRATA INPUT EINGANG		USCITA OUTPUT AUSGANG		MONTAGGIO ARRANGEMENT MONTAGE	ENTRATA INPUT EINGANG	CODICE CODE BESTELLNUMMER
	giri/min r.p.m. U/min. min ⁻¹	POTENZA POWER LEISTUNG CV kW	COPPIA TORQUE DREHEM N·m	COPPIA TORQUE DREHEM N·m			
1:2.5	540	60 44	795	310		X	6065.320.025Z
1:3.5	540	60 44	795	214		1928	X

PESO INDICATIVO APPROXIMATE WEIGHT GEWICHT CA.	OLIO CONSIGLIATO RECOMMENDED OIL EMPFOHLENES ÖL	MATERIALI MATERIALS WERKSTOFF			CUSCINETTI BEARINGS NADELLAGER				
		SCATOLA CASE GEHAUSE	ALBERI SHAFTS WELLEN	INGRANAGGI GEARS VERZÄHNUNG	A	B	C	D	E
kg									
21	SAE 90 kg 2	G 25	20MnCr5	20MnCr5	6210	6210	6208	6208	

**SCATOLE PER POMPE OLEODINAMICHE
GEARBOX FOR HYDRAULIC GEAR PUMPS
GETRIEBE FÜR ÖLKRAFTZAHNRADERPUMPEN**

REG

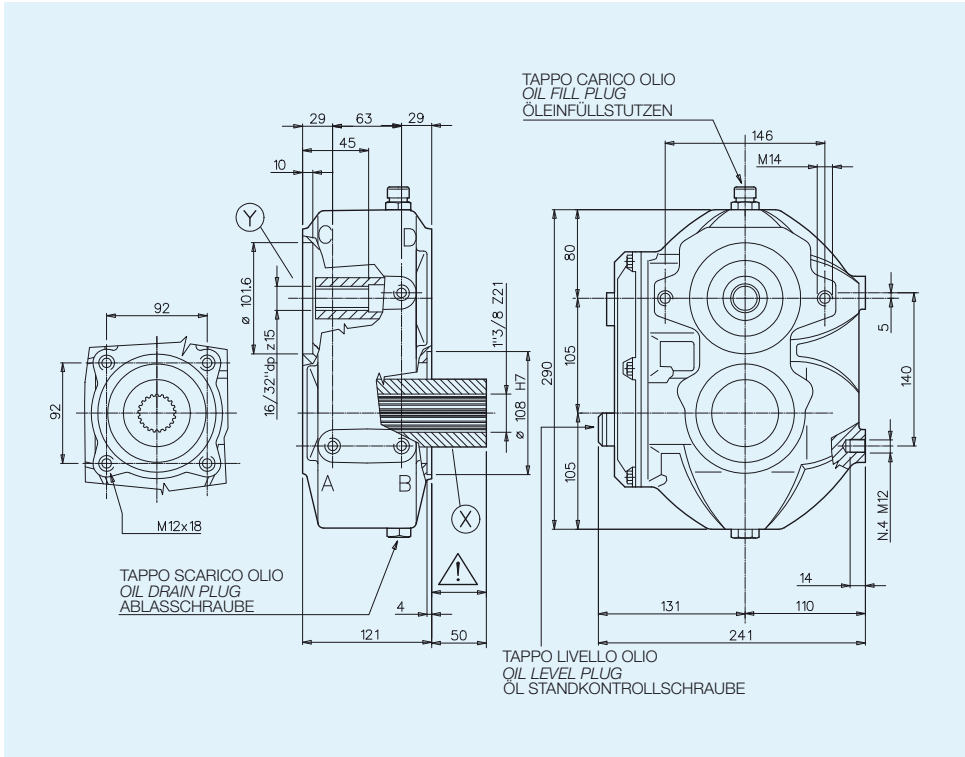

RAPPORTO RATIO VERHALTNIS	ENTRATA INPUT EINGANG		USCITA OUTPUT AUSGANG		MONTAGGIO ARRANGEMENT MONTAGE	ENTRATA INPUT EINGANG	CODICE CODE BESTELLNUMMER
	giri/min r.p.m. U/min. min ⁻¹	POTENZA POWER LEISTUNG CV kW	COPPIA TORQUE DREHEM N·m	COPPIA TORQUE DREHEM N·m			
1:2	540	70 51.5	928	480	1026	X	6065.324.020

PESO INDICATIVO APPROXIMATE WEIGHT GEWICHT CA.	OLIO CONSIGLIATO RECOMMENDED OIL EMPFOHLENES ÖL	MATERIALI MATERIALS WERKSTOFF			CUSCINETTI BEARINGS NADELLAGER				
		SCATOLA CASE GEHAUSE	ALBERI SHAFTS WELLEN	INGRANAGGI GEARS VERZÄHNUNG	A	B	C	D	E
kg									
21	SAE 90 kg 2	G 25	20MnCr5	20MnCr5	6210	6210	6307	6307	

SCATOLE PER POMPE OLEODINAMICHE GEARBOX FOR HYDRAULIC GEAR PUMPS GETRIEBE FÜR ÖLKRAFTZAHNRADERPUMPEN

REG

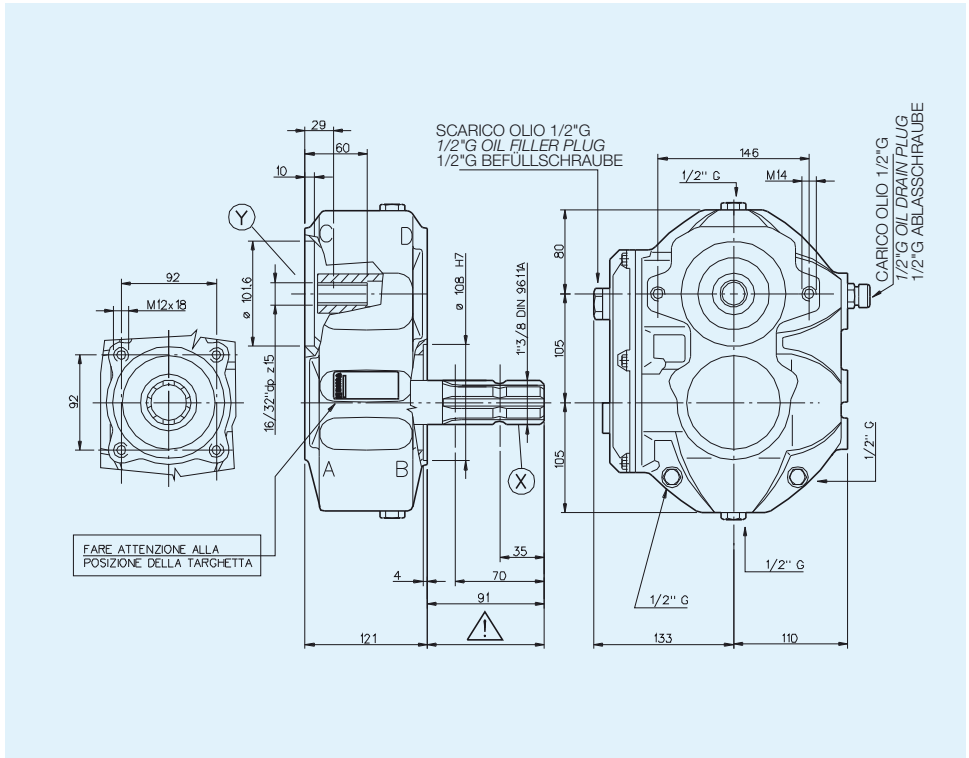

RAPPORTO RATIO VERHÄLTNIS	ENTRATA INPUT EINGANG			USCITA OUTPUT AUSGANG		MONTAGGIO ARRANGEMENT MONTAGE	ENTRATA INPUT EINGANG	CODICE CODE BESTELLNUMMER
	giri/min r.p.m. U/min. min ⁻¹	POTENZA POWER LEISTUNG CV kW	COPPIA TORQUE DREHEM N-m	COPPIA TORQUE DREHEM N-m	giri/min r.p.m. U/min. min ⁻¹			
1:2.5	540	60 44	795	310	1350		X	6065.327.025
1:2.5	1000	90 66	632	250	2500		X	6065.327.025
1:3	540	60 44	795	256	1620		X	6065.327.030
1:3.57	540	60 44	795	214	1928		X	6065.327.035
1:4	540	60 44	795	195	2160		X	6065.327.040
1:5	540	60 44	795	153	2700		X	6065.327.050

PESO INDICATIVO APPROXIMATE WEIGHT GEWICHT CA.	OLIO CONSIGLIATO RECOMMENDED OIL EMPFOHLENES ÖL	MATERIALI MATERIALS WERKSTOFF			CUSCINETTI BEARINGS NADELLAGER				
		SCATOLA CASE GEHAUSE	ALBERI SHAFTS WELLEN	INGRANAGGI GEARS VERZÄHNUNG	A	B	C	D	E
kg									
21	ISO VG 150-320 It 1,2	G 25	20MnCr5	20MnCr5	6210	6210	6208 6307	6208 6307	

SCATOLE PER POMPE OLEODINAMICHE GEARBOX FOR HYDRAULIC GEAR PUMPS GETRIEBE FÜR ÖLKRAFTZAHNRADERPUMPEN

REG

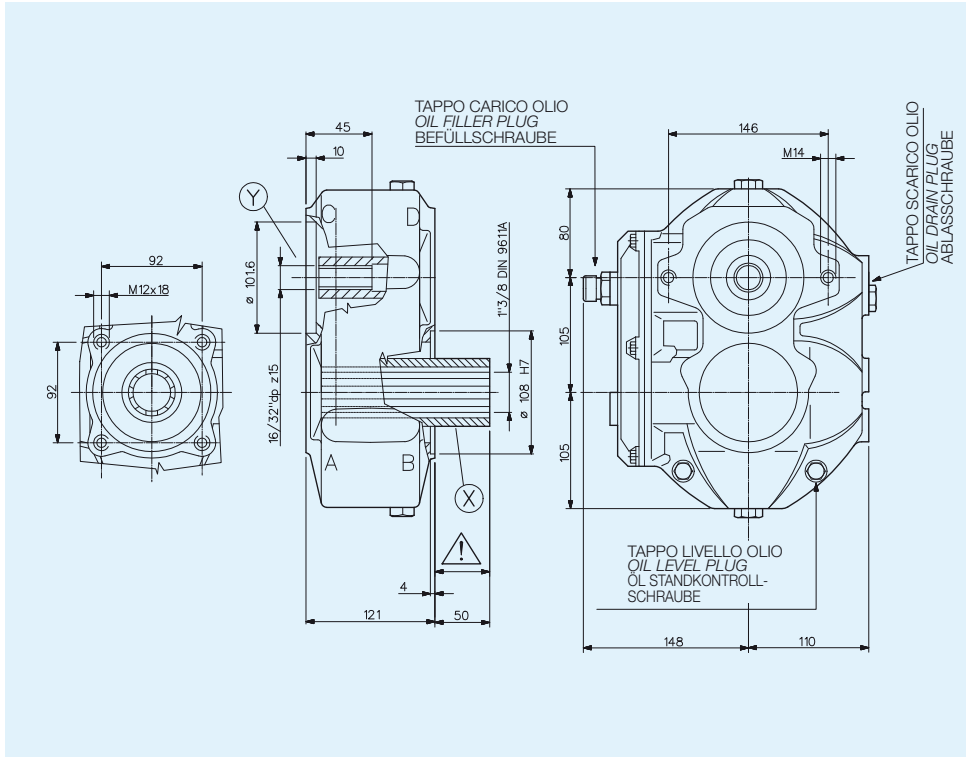

RAPPORTO RATIO VERHÄLTNIS	ENTRATA INPUT EINGANG		USCITA OUTPUT AUSGANG		MONTAGGIO ARRANGEMENT MONTAGE	ENTRATA INPUT EINGANG	CODICE CODE BESTELLNUMMER
	giri/min r.p.m. U/min. min ⁻¹	POTENZA POWER LEISTUNG CV kW	COPPIA TORQUE DREHEM N·m	COPPIA TORQUE DREHEM N·m			
1:3	540	60 44	795	256		X	6065.334.030
1:4	540	60 44	795	195		X	6065.334.040

PESO INDICATIVO APPROXIMATE WEIGHT GEWICHT CA.	OLIO CONSIGLIATO RECOMMENDED OIL EMPFOHLENES ÖL	MATERIALI MATERIALS WERKSTOFF			CUSCINETTI BEARINGS NADELLAGER				
		SCATOLA CASE GEHAUSE	ALBERI SHAFTS WELLEN	INGRANAGGI GEARS VERZÄHNUNG	A	B	C	D	E
kg									
21	SAE 90 kg 1	G 25	20MnCr5	20MnCr5	6210	6210	6208	6208	

SCATOLE PER POMPE OLEODINAMICHE GEARBOX FOR HYDRAULIC GEAR PUMPS GETRIEBE FÜR ÖLKRAFTZAHNRADERPUMPEN

M9

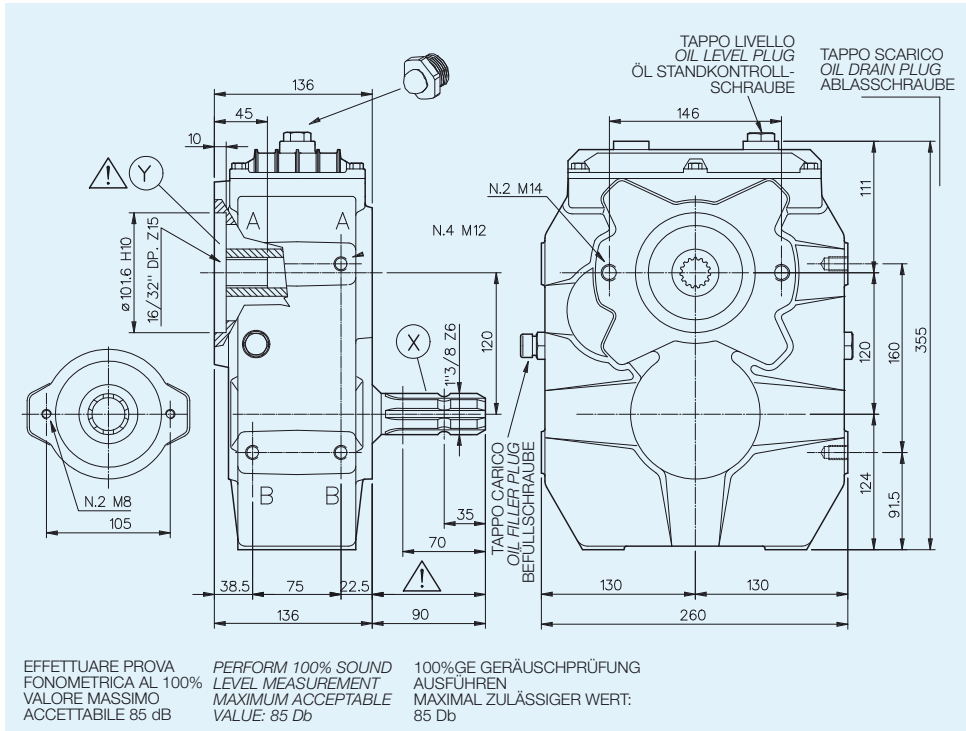

RAPPORTO RATIO VERHÄLTNIS	INGRESSO INPUT EINGANG				USCITA OUTPUT AUSGANG		MONTAGGIO ARRANGEMENT MONTAGE	ENTRATA INPUT EINGANG	CODICE CODE BESTELLNUMMER
	min ⁻¹	POTENZA POWER LEISTUNG		COPPIA TORQUE DREHM.		min ⁻¹			
1:2,62	540	75	55	994	390	1415		X	6084.001.025
	1000	110	80.9	773	297	2640		X	
	2,62:1	2620	110	80.9	309	742		1000	
1:3	540	75	55	994	330	1620		X	6084.001.030
	1000	113	83	795	262	3000		X	
1:4	540	75	55	994	245	2160		X	6084.001.040
	1000	113	83	795	197	4000	X		
1:5	540	70	51.5	928	180	2700	X	6084.001.050	
	2700	70	51.5	188	928	540	X		
	5:1	2700	70	51.5	188	928	540		Y

PESO INDICATIVO APPROXIMATE WEIGHT GEWICHT CA.	OLIO CONSIGLIATO RECOMMENDED OIL EMPFOHLENES ÖL	MATERIALI MATERIALS WERKSTOFF			CUSCINETTI BEARINGS NADELLAGER				
		SCATOLA CASE GEHAUSE	ALBERI SHAFTS WELLEN	INGRANAGGI GEARS VERZÄHNUNG	A	B	C	D	E
Kg.	SAE 90 Kg.	G 25	20MnCr5	20MnCr5	6307	6210			
32	1,8	G 25	20MnCr5	20MnCr5	6307	6210			

SCATOLE PER POMPE OLEODINAMICHE GEARBOX FOR HYDRAULIC GEAR PUMPS GETRIEBE FÜR ÖLKRAFTZAHNRADERPUMPEN

M9

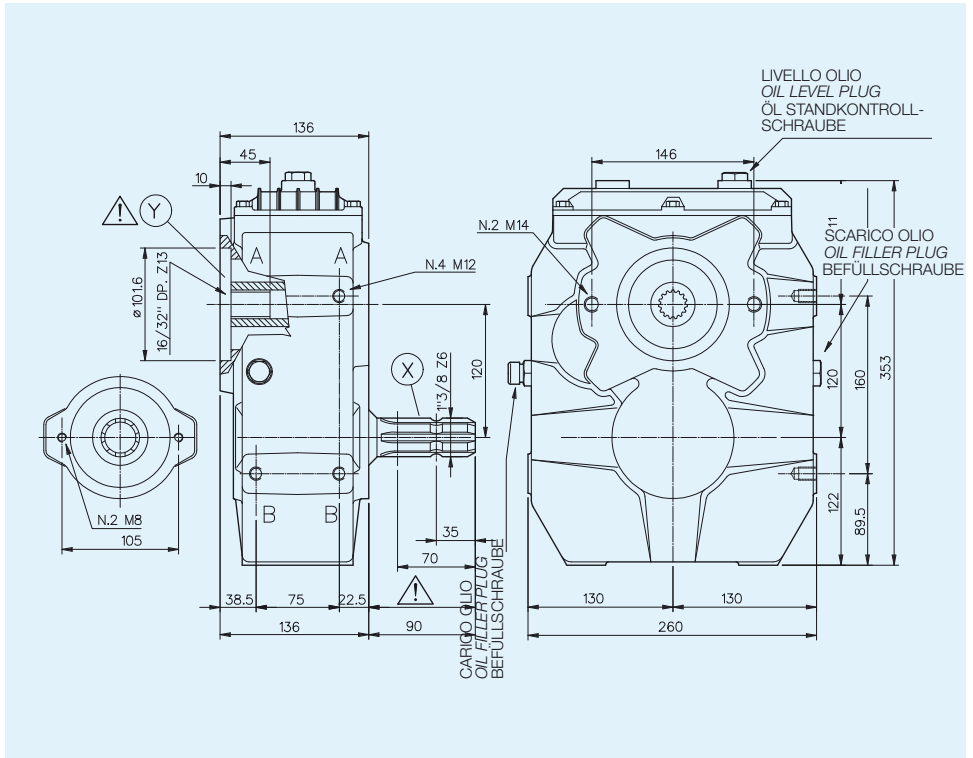

RAPPORTO RATIO VERHÄLTNIS	ENTRATA INPUT EINGANG		USCITA OUTPUT AUSGANG		MONTAGGIO ARRANGEMENT MONTAGE	ENTRATA INPUT EINGANG	CODICE CODE BESTELLNUMMER
	giri/min r.p.m. U/min. min ⁻¹	POTENZA POWER LEISTUNG CV kW	COPPIA TORQUE DREHEM N·m	COPPIA TORQUE DREHEM N·m			
1:2.5	1000	110 80.9	773	297		X	6084.303.025
1:3	540	75 55	994	330		X	6084.303.030

PESO INDICATIVO APPROXIMATE WEIGHT GEWICHT CA.	OLIO CONSIGLIATO RECOMMENDED OIL EMPFOHLENES ÖL	MATERIALI MATERIALS WERKSTOFF			CUSCINETTI BEARINGS NADELLAGER				
		SCATOLA CASE GEHAUSE	ALBERI SHAFTS WELLEN	INGRANAGGI GEARS VERZÄHNUNG	A	B	C	D	E
kg									
36	SAE 90 kg 2	G 25	20MnCr5	20MnCr5	6307	6210			

SCATOLE PER POMPE OLEODINAMICHE GEARBOX FOR HYDRAULIC GEAR PUMPS GETRIEBE FÜR ÖLKRAFTZAHNRADERPUMPEN

M9

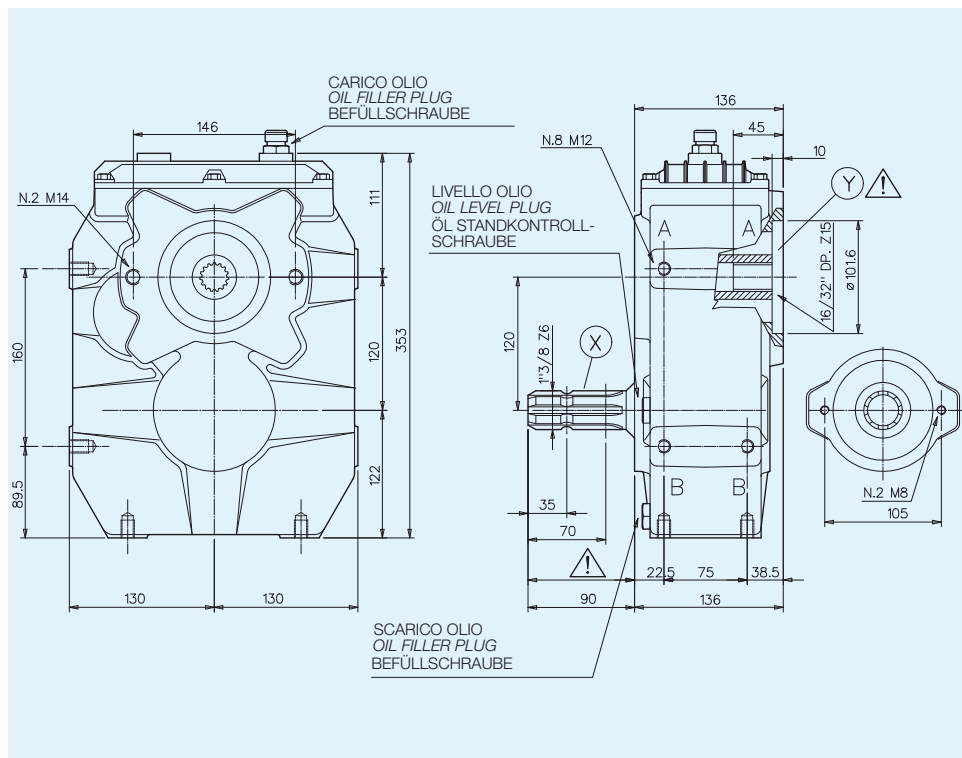

RAPPORTO RATIO VERHALTNIS	ENTRATA INPUT EINGANG		USCITA OUTPUT AUSGANG		MONTAGGIO ARRANGEMENT MONTAGE	ENTRATA INPUT EINGANG	CODICE CODE BESTELLNUMMER
	giri/min r.p.m. U/min. min ⁻¹	POTENZA POWER LEISTUNG CV kW	COPPIA TORQUE DREHEM N·m	COPPIA TORQUE DREHEM N·m			
1:4	540	75 55	994	245	2160	X	6084.305.040
1:5	540	70 51.5	928	180	2700	X	6084.305.050
5:1	2700	70 51.5	188	928	540	Y	6084.305.050

PESO INDICATIVO APPROXIMATE WEIGHT GEWICHT CA.	OLIO CONSIGLIATO RECOMMENDED OIL EMPFOHLENES ÖL	MATERIALI MATERIALS WERKSTOFF			CUSCINETTI BEARINGS NADELLAGER					
		SCATOLA CASE GEHAUSE	ALBERI SHAFTS WELLEN	INGRANAGGI GEARS VERZÄHNUNG	A	B	C	D	E	
kg										
36	SAE 90 kg 2	G 25	20MnCr5	20MnCr5	6307	6210				

SCATOLE PER POMPE OLEODINAMICHE GEARBOX FOR HYDRAULIC GEAR PUMPS GETRIEBE FÜR ÖLKRAFTZAHNRADERPUMPEN

M9

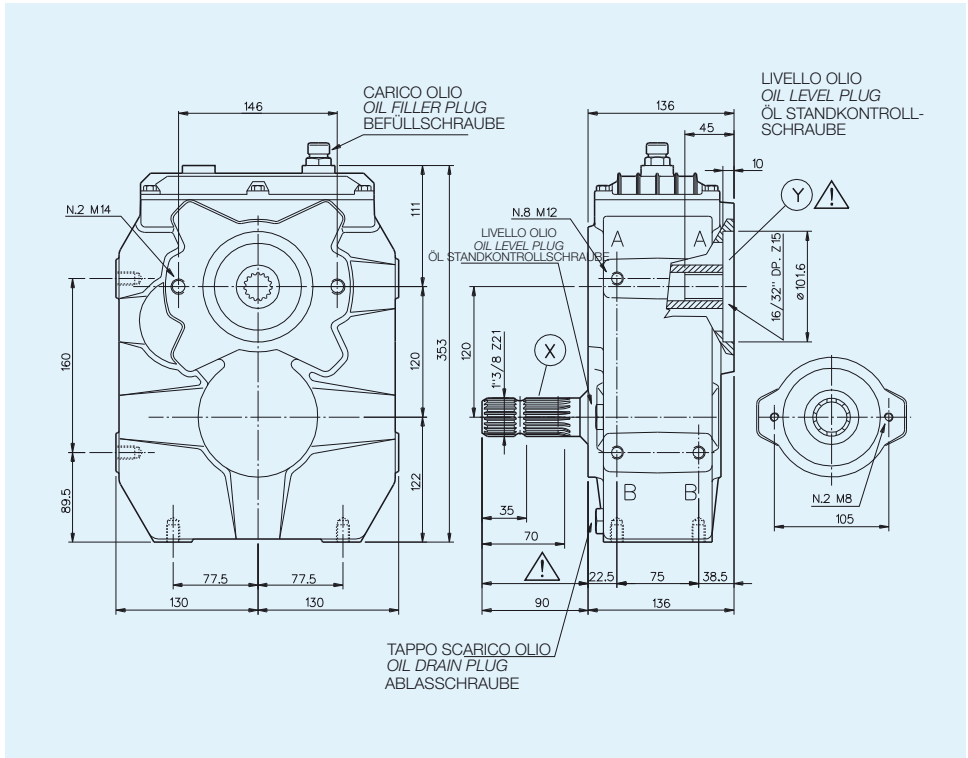

RAPPORTO RATIO VERHÄLTNIS	ENTRATA INPUT EINGANG		USCITA OUTPUT AUSGANG		MONTAGGIO ARRANGEMENT MONTAGE	ENTRATA INPUT EINGANG	CODICE CODE BESTELLNUMMER
	giri/min r.p.m. U/min. min ⁻¹	POTENZA POWER LEISTUNG CV kW	COPPIA TORQUE DREHEM N·m	COPPIA TORQUE DREHEM N·m			
1:2.5	540	75 55	994	390		X	6084.306.025
2.5:1	2500	110 80.9	315	775		Y	6084.306.025
1:4	540	75 55	994	245		X	6084.306.040

PESO INDICATIVO APPROXIMATE WEIGHT GEWICHT CA.	OLIO CONSIGLIATO RECOMMENDED OIL EMPFOHLENES ÖL	MATERIALI MATERIALS WERKSTOFF			CUSCINETTI BEARINGS NADELLAGER				
		SCATOLA CASE GEHAUSE	ALBERI SHAFTS WELLEN	INGRANAGGI GEARS VERZÄHNUNG	A	B	C	D	E
kg									
36	SAE 90 kg 1.3	G 25	20MnCr5	20MnCr5	6307	6210			

SCATOLE PER POMPE OLEODINAMICHE GEARBOX FOR HYDRAULIC GEAR PUMPS GETRIEBE FÜR ÖLKRAFTZAHNRADERPUMPEN

M9

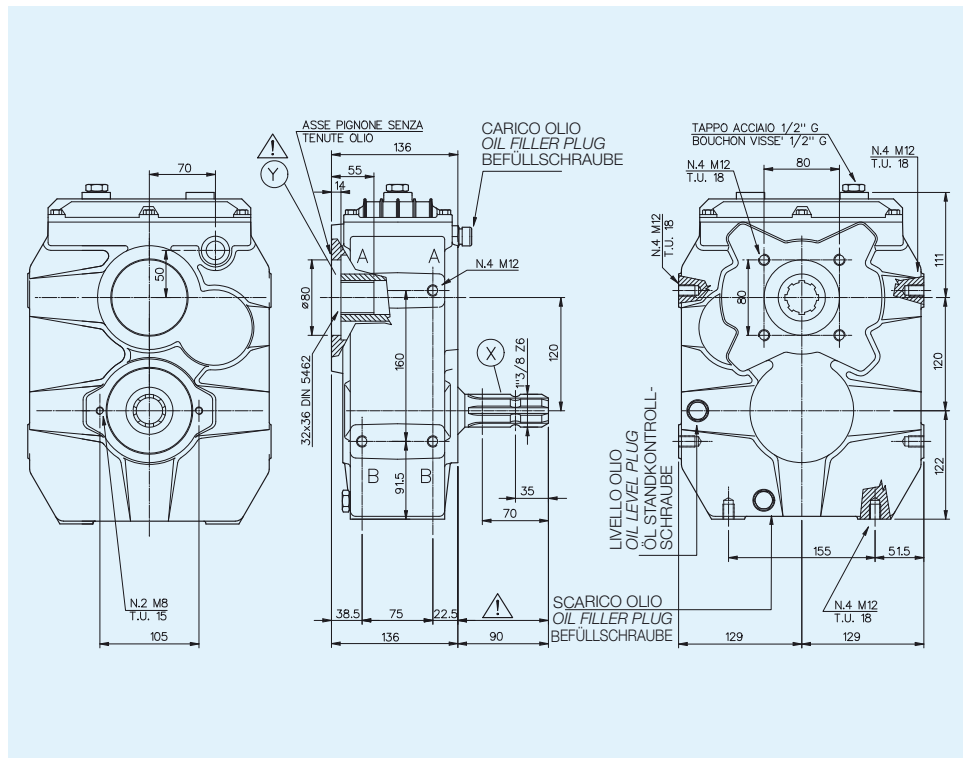

RAPPORTO RATIO VERHÄLTNIS	ENTRATA INPUT EINGANG		USCITA OUTPUT AUSGANG			MONTAGGIO ARRANGEMENT MONTAGE	ENTRATA INPUT EINGANG	CODICE CODE BESTELLNUMMER
	giri/min r.p.m. U/min. min ⁻¹	POTENZA POWER LEISTUNG CV kW	COPPIA TORQUE DREHEM N·m	COPPIA TORQUE DREHEM N·m	giri/min r.p.m. U/min. min ⁻¹			
1:1.35	1000	113 83	809	587	1350		X	6084.307.013
1:2.5	540	75 55	994	390	1350		X	6084.307.025

PESO INDICATIVO APPROXIMATE WEIGHT GEWICHT CA.	OLIO CONSIGLIATO RECOMMENDED OIL EMPFOHLENES ÖL	MATERIALI MATERIALS WERKSTOFF			CUSCINETTI BEARINGS NADELLAGER					
		SCATOLA CASE GEHAUSE	ALBERI SHAFTS WELLEN	INGRANAGGI GEARS VERZÄHNUNG	A	B	C	D	E	
kg										
36	SAE 90 kg 2	G 25	20MnCr5	20MnCr5	30210	30210				

SCATOLE PER POMPE OLEODINAMICHE GEARBOX FOR HYDRAULIC GEAR PUMPS GETRIEBE FÜR ÖLKRAFTZAHNRADERPUMPEN

M9

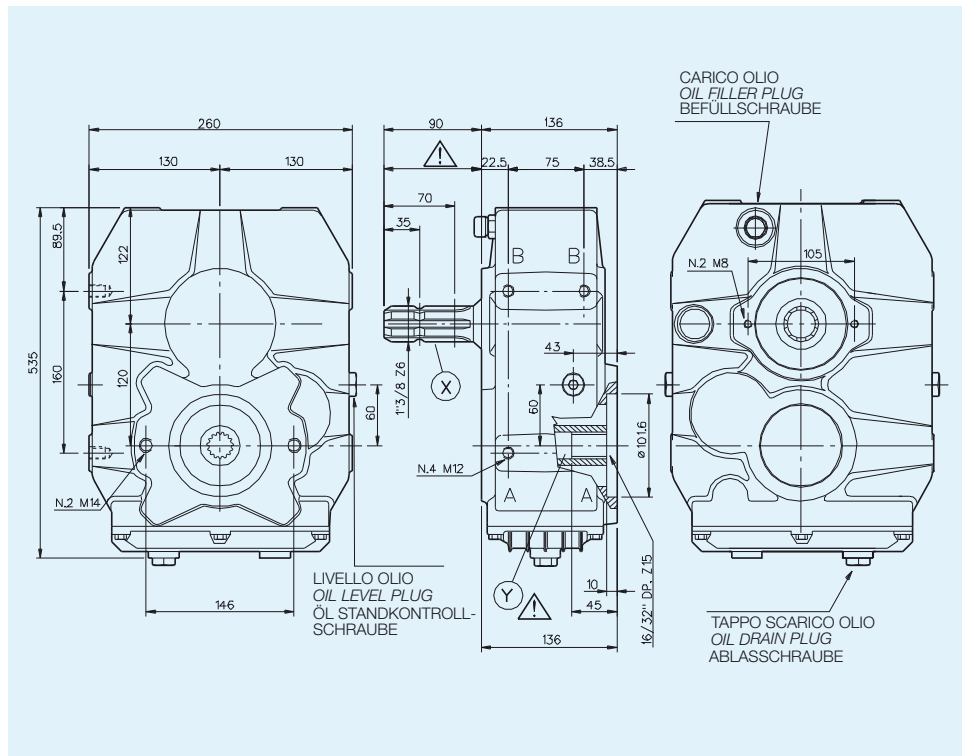

RAPPORTO RATIO VERHÄLTNIS	ENTRATA INPUT EINGANG		USCITA OUTPUT AUSGANG		MONTAGGIO ARRANGEMENT MONTAGE	ENTRATA INPUT EINGANG	CODICE CODE BESTELLNUMMER
	giri/min r.p.m. U/min. min ⁻¹	POTENZA POWER LEISTUNG CV kW	COPPIA TORQUE DREHEM N·m	COPPIA TORQUE DREHEM N·m			
1:2.5	1000	110 80.9	773	297	2500	X	6084.314.025
1:4	540	75 55	994	245	2160	X	6084.314.040
1:4.5	540	75 55	994	218	2430	X	6084.314.045

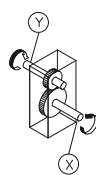

PESO INDICATIVO APPROXIMATE WEIGHT GEWICHT CA.	OLIO CONSIGLIATO RECOMMENDED OIL EMPFOHLENES ÖL	MATERIALI MATERIALS WERKSTOFF			CUSCINETTI BEARINGS NADELLAGER				
		SCATOLA CASE GEHAUSE	ALBERI SHAFTS WELLEN	INGRANAGGI GEARS VERZÄHNUNG	A	B	C	D	E
kg	ISO VG 150-320 LT. 2,4	G 25	20MnCr5	20MnCr5	6307	6210			
33	SAE 90 kg 2	G 25	20MnCr5	20MnCr5	6307	6210			

SCATOLE PER POMPE OLEODINAMICHE GEARBOX FOR HYDRAULIC GEAR PUMPS GETRIEBE FÜR ÖLKRAFTZAHNRADERPUMPEN

M9

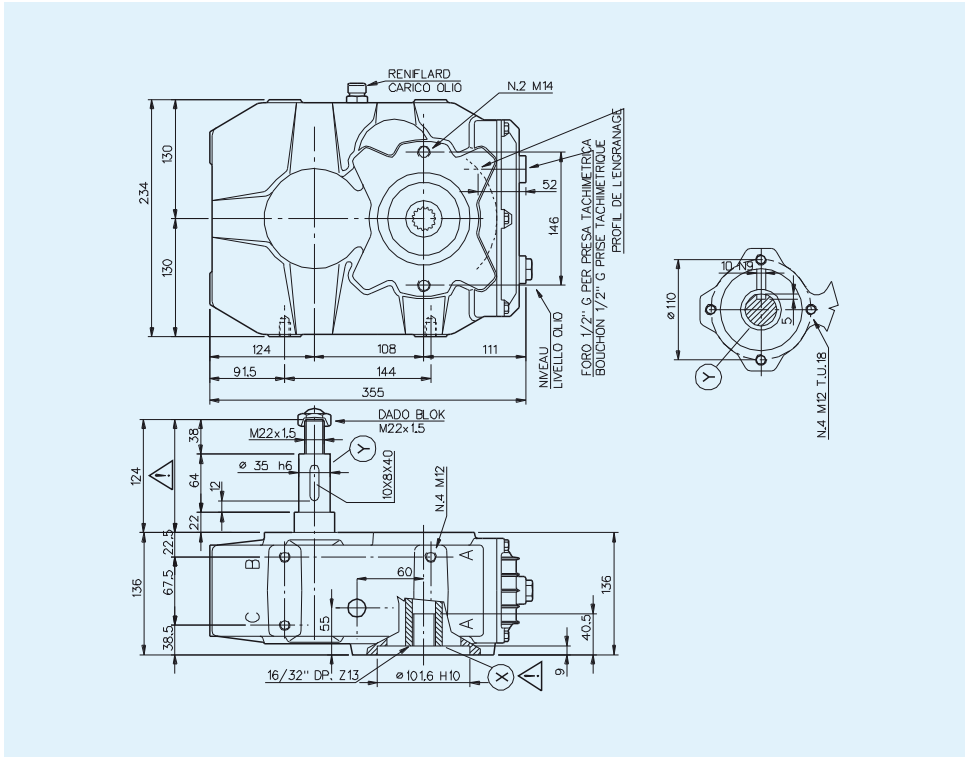

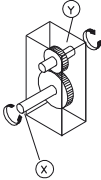
RAPPORTO RATIO VERHALTNIS	ENTRATA INPUT EINGANG		USCITA OUTPUT AUSGANG			MONTAGGIO ARRANGEMENT MONTAGE	ENTRATA INPUT EINGANG	CODICE CODE BESTELLNUMMER
	giri/min r.p.m. U/min. min ⁻¹	POTENZA POWER LEISTUNG CV kW	COPPIA TORQUE DREHEM N·m	COPPIA TORQUE DREHEM N·m	giri/min r.p.m. U/min. min ⁻¹			
1:2	2000	57 42	200	96	4000		X	6084.319.020

PESO INDICATIVO APPROXIMATE WEIGHT GEWICHT CA.	OLIO CONSIGLIATO RECOMMENDED OIL EMPFOHLENES ÖL	MATERIALI MATERIALS WERKSTOFF			CUSCINETTI BEARINGS NADELLAGER					
		SCATOLA CASE GEHAUSE	ALBERI SHAFTS WELLEN	INGRANAGGI GEARS VERZAHNUNG	A	B	C	D	E	
kg										
32	SAE 90 kg 2	G 25	20MnCr5	20MnCr5	6208	6210	6308			

SCATOLE PER POMPE OLEODINAMICHE GEARBOX FOR HYDRAULIC GEAR PUMPS GETRIEBE FÜR ÖLKRAFTZAHNRADERPUMPEN

M9

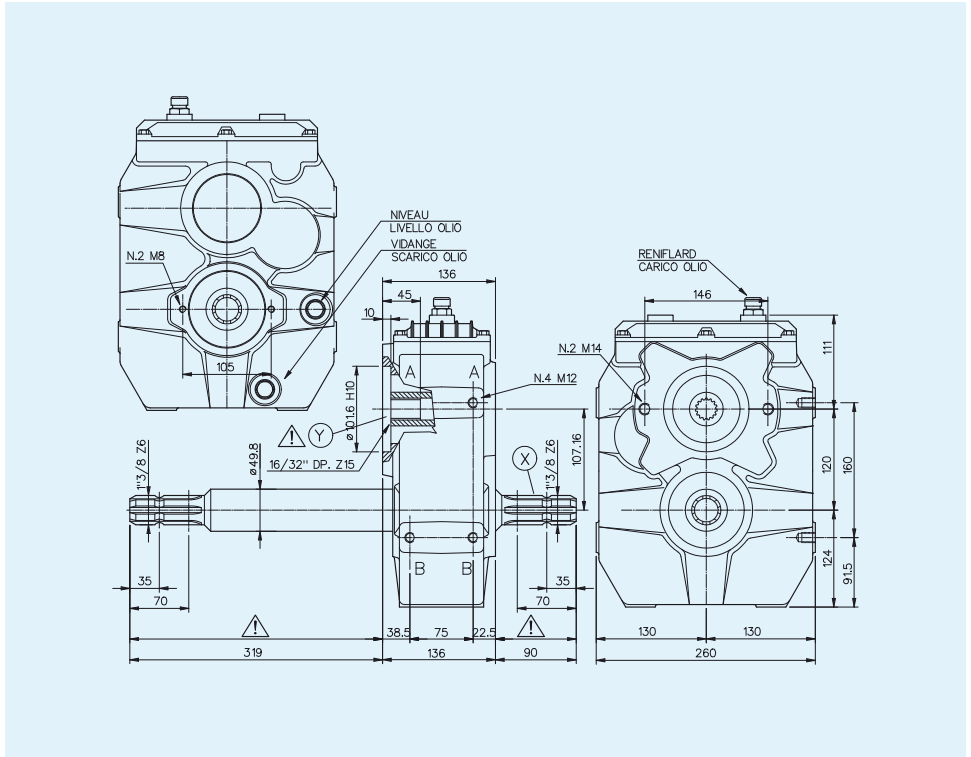

RAPPORTO RATIO VERHALTNIS	ENTRATA INPUT EINGANG		USCITA OUTPUT AUSGANG		MONTAGGIO ARRANGEMENT MONTAGE	ENTRATA INPUT EINGANG	CODICE CODE BESTELLNUMMER
	giri/min r.p.m. U/min. min ⁻¹	POTENZA POWER LEISTUNG CV kW	COPPIA TORQUE DREHEM N·m	COPPIA TORQUE DREHEM N·m			
1:4	540	75 55	994	245	2160	X	6084.320.040

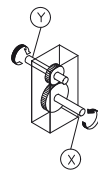

PESO INDICATIVO APPROXIMATE WEIGHT GEWICHT CA.	OLIO CONSIGLIATO RECOMMENDED OIL EMPFOHLENES ÖL	MATERIALI MATERIALS WERKSTOFF		CUSCINETTI BEARINGS NADELLAGER				
		SCATOLA CASE GEHAUSE	ALBERI SHAFTS WELLEN	INGRANAGGI GEARS VERZÄHNUNGEN	B	C	D	E
kg		G 25	20MnCr5	20MnCr5	6307	6210		
36	SAE 90 kg 2							

SCATOLE PER POMPE OLEODINAMICHE GEARBOX FOR HYDRAULIC GEAR PUMPS GETRIEBE FÜR ÖLKRAFTZAHNRADERPUMPEN

M9

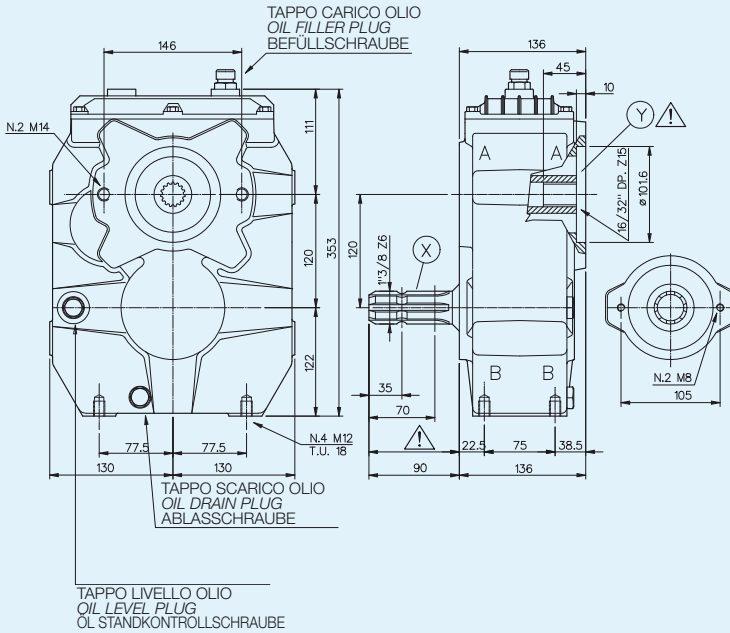

RAPPORTO RATIO VERHALTNIS	ENTRATA INPUT EINGANG		USCITA OUTPUT AUSGANG			MONTAGGIO ARRANGEMENT MONTAGE	ENTRATA INPUT EINGANG	CODICE CODE BESTELLNUMMER
	giri/min r.p.m. U/min. min ⁻¹	POTENZA POWER LEISTUNG CV kW	COPPIA TORQUE DREHEM N·m	COPPIA TORQUE DREHEM N·m	giri/min r.p.m. U/min. min ⁻¹			
1:2.5	540	75 55	994	390	1350		X	6084.321.025
1:2.5	1000	110 80.9	773	297	2500		X	6084.321.025
1:4	540	75 55	994	245	2160		X	6084.321.040

PESO INDICATIVO APPROXIMATE WEIGHT GEWICHT CA.	OLIO CONSIGLIATO RECOMMENDED OIL EMPFOHLENES ÖL	MATERIALI MATERIALS WERKSTOFF			CUSCINETTI BEARINGS NADELLAGER					
		SCATOLA CASE GEHAUSE	ALBERI SHAFTS WELLEN	INGRANAGGI GEARS VERZÄHNUNG	A	B	C	D	E	
kg										
36	SAE 90 kg 1.8	G 25	20MnCr5	20MnCr5	6307	6210				

SCATOLE PER POMPE OLEODINAMICHE GEARBOX FOR HYDRAULIC GEAR PUMPS GETRIEBE FÜR ÖLKRAFTZAHNRADERPUMPEN

M9

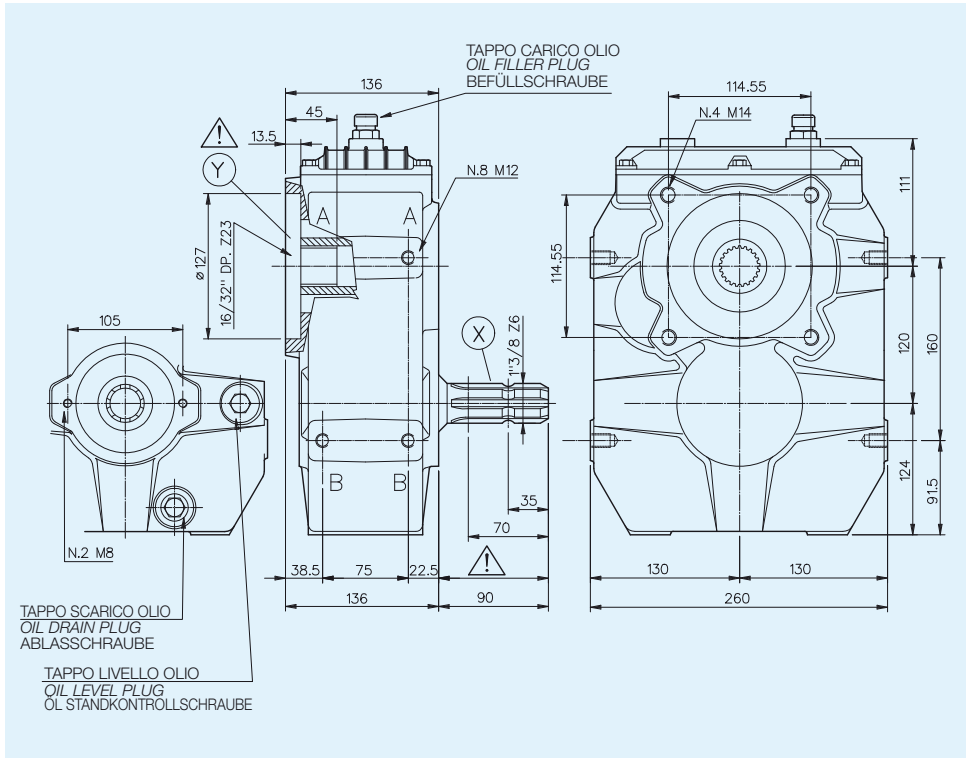

RAPPORTO RATIO VERHÄLTNIS	ENTRATA INPUT EINGANG		USCITA OUTPUT AUSGANG		MONTAGGIO ARRANGEMENT MONTAGE	ENTRATA INPUT EINGANG	CODICE CODE BESTELLNUMMER
	giri/min r.p.m. U/min. min ⁻¹	POTENZA POWER LEISTUNG CV kW	COPPIA TORQUE DREHEM N·m	COPPIA TORQUE DREHEM N·m			
2:1	1000	50 36.8	351	675		Y	6084.323.020
1:2	1000	80 39	562	275		X	6084.323.020

PESO INDICATIVO APPROXIMATE WEIGHT GEWICHT CA.	OLIO CONSIGLIATO RECOMMENDED OIL EMPFOHLENES ÖL	MATERIALI MATERIALS WERKSTOFF			CUSCINETTI BEARINGS NADELLAGER				
		SCATOLA CASE GEHAUSE	ALBERI SHAFTS WELLEN	INGRANAGGI GEARS VERZÄHNUNG	A	B	C	D	E
kg									
39	MOBIL SHC630 kg 2	G 25	20MnCr5	20MnCr5	6210	6210			

SCATOLE PER POMPE OLEODINAMICHE GEARBOX FOR HYDRAULIC GEAR PUMPS GETRIEBE FÜR ÖLKRAFTZAHNRADERPUMPEN

M9

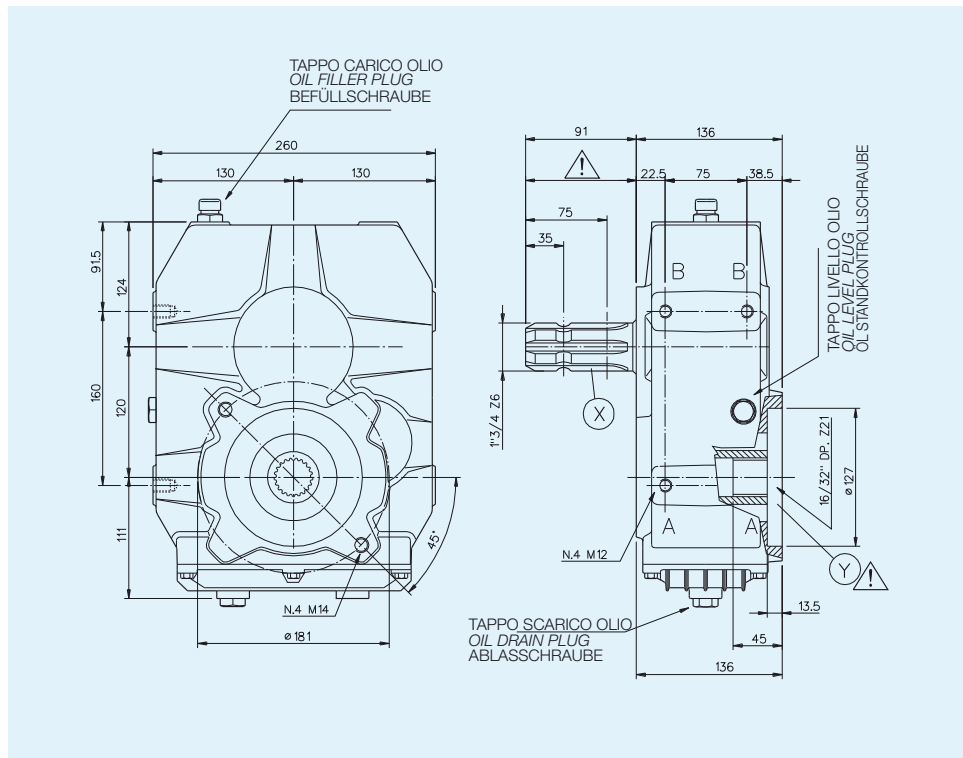

RAPPORTO RATIO VERHALTNIS	ENTRATA INPUT EINGANG		USCITA OUTPUT AUSGANG		MONTAGGIO ARRANGEMENT MONTAGE	ENTRATA INPUT EINGANG	CODICE CODE BESTELLNUMMER
	giri/min r.p.m. U/min. min ⁻¹	POTENZA POWER LEISTUNG CV kW	COPPIA TORQUE DREHEM N·m	COPPIA TORQUE DREHEM N·m			
1:3	1000	105 77	738	236		X	6084.327.030
1:1.86	1700	140 103	578	302		X	6084.327.018

PESO INDICATIVO APPROXIMATE WEIGHT GEWICHT CA.	OLIO CONSIGLIATO RECOMMENDED OIL EMPFOHLENES ÖL	MATERIALI MATERIALS WERKSTOFF			CUSCINETTI BEARINGS NADELLAGER					
		SCATOLA CASE GEHAUSE	ALBERI SHAFTS WELLEN	INGRANAGGI GEARS VERZÄHNUNG	A	B	C	D	E	
kg										
39	MOBIL SHC630 kg 2	G 25	20MnCr5	20MnCr5	30210	6210				

SCATOLE PER POMPE OLEODINAMICHE GEARBOX FOR HYDRAULIC GEAR PUMPS GETRIEBE FÜR ÖLKRAFTZAHNRADERPUMPEN

M9

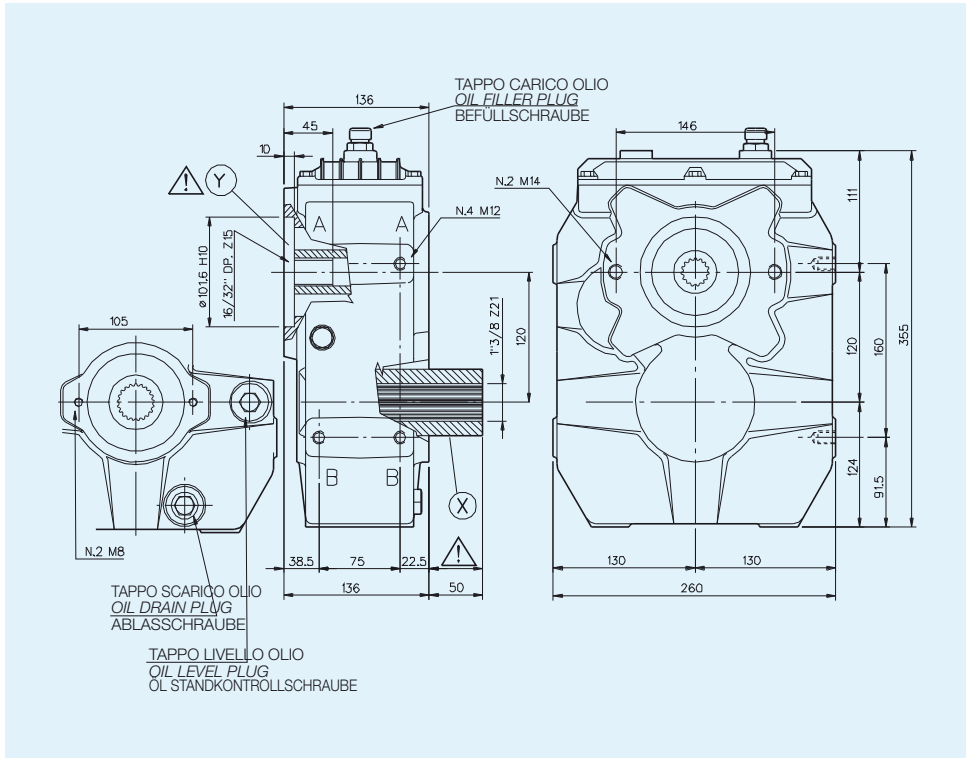

RAPPORTO RATIO VERHÄLTNIS	ENTRATA INPUT EINGANG		USCITA OUTPUT AUSGANG		MONTAGGIO ARRANGEMENT MONTAGE	ENTRATA INPUT EINGANG	CODICE CODE BESTELLNUMMER	
	giri/min r.p.m. U/min. min ⁻¹	POTENZA POWER LEISTUNG CV kW	COPPIA TORQUE DREHEM N·m	COPPIA TORQUE DREHEM N·m				giri/min r.p.m. U/min. min ⁻¹
1:2.62	540	75	55	994	390	1415	X	6084.330.025
1:4	540	75	55	994	245	2160	X	6084.330.040

PESO INDICATIVO APPROXIMATE WEIGHT GEWICHT CA.	OLIO CONSIGLIATO RECOMMENDED OIL EMPFOHLENES ÖL	MATERIALI MATERIALS WERKSTOFF			CUSCINETTI BEARINGS NADELLAGER				
		SCATOLA CASE GEHAUSE	ALBERI SHAFTS WELLEN	INGRANAGGI GEARS VERZÄHNUNG	A	B	C	D	E
kg									
36	SAE 90 kg 1.8	G 25	20MnCr5	20MnCr5	6307	6210			

SCATOLE PER POMPE OLEODINAMICHE GEARBOX FOR HYDRAULIC GEAR PUMPS GETRIEBE FÜR ÖLKRAFTZAHNRADERPUMPEN

M9

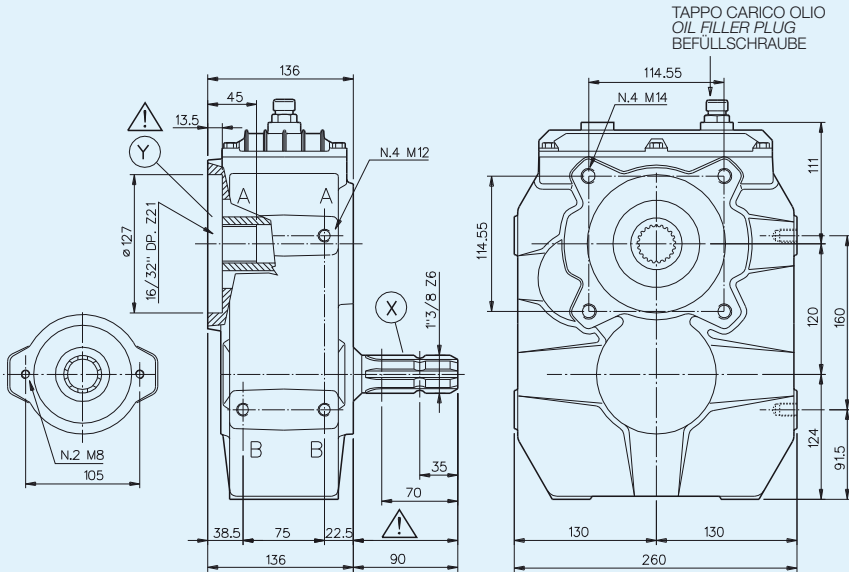

RAPPORTO RATIO VERHÄLTNIS	ENTRATA INPUT EINGANG		USCITA OUTPUT AUSGANG		MONTAGGIO ARRANGEMENT MONTAGE	ENTRATA INPUT EINGANG	CODICE CODE BESTELLNUMMER	
	giri/min r.p.m. U/min. min ⁻¹	POTENZA POWER LEISTUNG CV kW	COPPIA TORQUE DREHEM N·m	COPPIA TORQUE DREHEM N·m				giri/min r.p.m. U/min. min ⁻¹
1:2,62	540	75 55	994	390		X	6084.311.026	
1:2,62	1000	110 80,9	773	297		X	6084.311.026	
2,62:1	2620	110 80,9	309	742		1000	Y	6084.311.026
4:1	2160	70 51,4	232	920		540	Y	6084.331.040
1:4	540	70 51,4	910	220		2160	Y	6084.331.040
3:1	2000	90 66	316	910		666	Y	6084.331.030
1:3	540	75 55	994	330		1620	Y	6084.331.030
1:3	1000	113 83	795	262		3000	Y	6084.331.030

PESO INDICATIVO APPROXIMATE WEIGHT GEWICHT CA.	OLIO CONSIGLIATO RECOMMENDED OIL EMPFOHLENES ÖL	MATERIALI MATERIALS WERKSTOFF			CUSCINETTI BEARINGS NADELLAGER				
		SCATOLA CASE GEHAUSE	ALBERI SHAFTS WELLEN	INGRANAGGI GEARS VERZÄHNUNG	A	B	C	D	E
kg									
39	MOBIL SHC630 kg 2	G 25	20MnCr5	20MnCr5	6210	6210			

SCATOLE PER POMPE OLEODINAMICHE GEARBOX FOR HYDRAULIC GEAR PUMPS GETRIEBE FÜR ÖLKRAFTZAHNRADERPUMPEN

M9

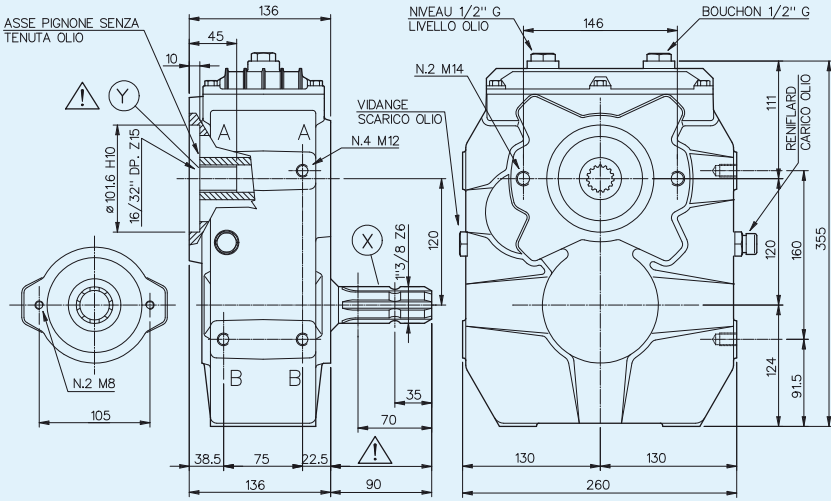

EFFETTUARE PROVA FONOMETRICA AL 100%
MASSIMO VALORE ACCETTABILE: 85 Db
PERFORM 100% SOUND LEVEL MEASUREMENT
MAXIMUM ACCEPTABLE VALUE: 85 Db
100%GE GERÄUSCHPRÜFUNG AUSFÜHREN
MAXIMAL ZULÄSSIGER WERT: 85 Db

RAPPORTO RATIO VERHALTNIS	ENTRATA INPUT EINGANG		USCITA OUTPUT AUSGANG		MONTAGGIO ARRANGEMENT MONTAGE	ENTRATA INPUT EINGANG	CODICE CODE BESTELLNUMMER
	giri/min r.p.m. U/min. min ⁻¹	POTENZA POWER LEISTUNG CV kW	COPPIA TORQUE DREHEM N·m	COPPIA TORQUE DREHEM N·m			
1:2.62	540	75 55	994	390		X	6084.332.025
1:2.62	1000	110 80.9	773	297		X	6084.332.025
2.62:1	2620	110 80.9	309	742		Y	6084.332.025
1:4	540	75 55	994	245		X	6084.332.040

PESO INDICATIVO APPROXIMATE WEIGHT GEWICHT CA.	OLIO CONSIGLIATO RECOMMENDED OIL EMPFOHLENES ÖL	MATERIALI MATERIALS WERKSTOFF			CUSCINETTI BEARINGS NADELLAGER					
		SCATOLA CASE GEHAUSE	ALBERI SHAFTS WELLEN	INGRANAGGI GEARS VERZÄHNUNG	A	B	C	D	E	
kg										
36	SAE 90 kg 1.8	G 25	20MnCr5	20MnCr5	6307	6210				

SCATOLE PER POMPE OLEODINAMICHE GEARBOX FOR HYDRAULIC GEAR PUMPS GETRIEBE FÜR ÖLKRAFTZAHNRADERPUMPEN

M9

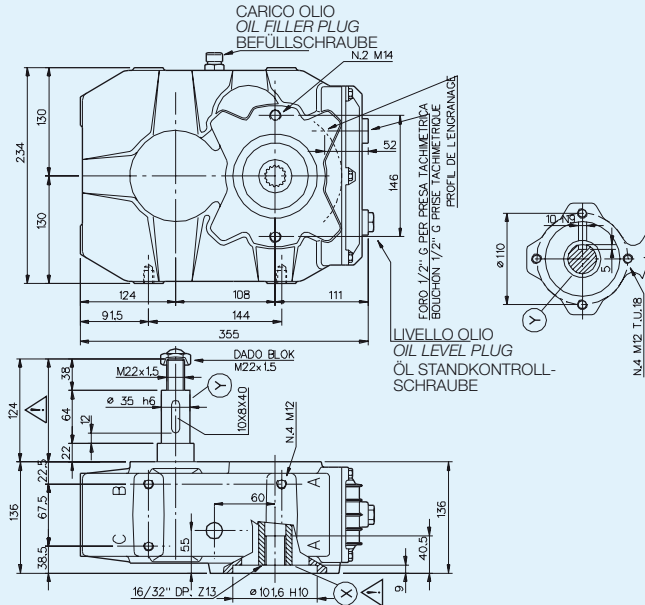

RAPPORTO RATIO VERHÄLTNIS	ENTRATA INPUT EINGANG		USCITA OUTPUT AUSGANG		MONTAGGIO ARRANGEMENT MONTAGE	ENTRATA INPUT EINGANG	CODICE CODE BESTELLNUMMER
	giri/min r.p.m. U/min. min ⁻¹	POTENZA POWER LEISTUNG CV kW	COPPIA TORQUE DREHEM N·m	COPPIA TORQUE DREHEM N·m			
1:2	2000	57 42	200	96	4000	X	6084.319.020

PESO INDICATIVO APPROXIMATE WEIGHT GEWICHT CA.	OLIO CONSIGLIATO RECOMMENDED OIL EMPFOHLENES ÖL	MATERIALI MATERIALS WERKSTOFF			CUSCINETTI BEARINGS NADELLAGER				
		SCATOLA CASE GEHAUSE	ALBERI SHAFTS WELLEN	INGRANAGGI GEARS VERZÄHNUNG	A	B	C	D	E
kg									
32	SAE 90 kg 2	G 25	20MnCr5	20MnCr5	6208	6210	6308		

SCATOLE PER POMPE OLEODINAMICHE GEARBOX FOR HYDRAULIC GEAR PUMPS GETRIEBE FÜR ÖLKRAFTZAHNRADERPUMPEN

M10

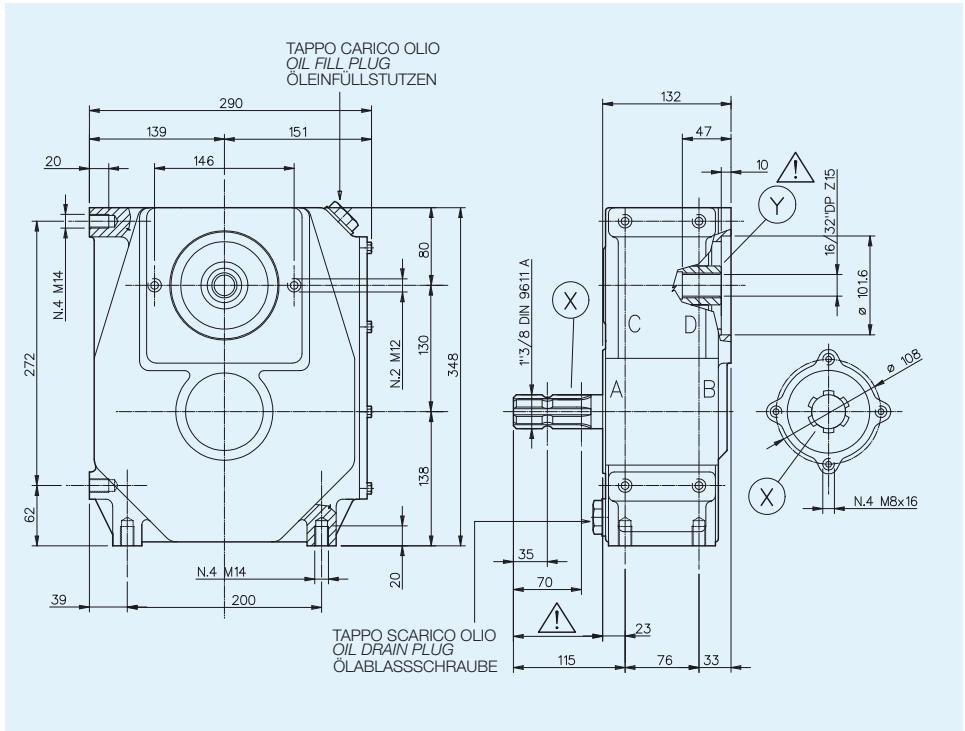

RAPPORTO RATIO VERHÄLTNIS	INGRESSO INPUT EINGANG			USCITA OUTPUT AUSGANG		MONTAGGIO ARRANGEMENT MONTAGE	ENTRATA INPUT EINGANG	CODICE CODE BESTELLNUMMER
	min ⁻¹	POTENZA POWER LEISTUNG CV	kW	COPPIA TORQUE DREHM. N-m	COPPIA TORQUE DREHM. N-m			
1:2	540	90	66	1193	589	1080	X	6016.329.020
1:2,5	540	85	62.5	1127	445	1350	X	6016.329.025
1:3,8	540	85	62.5	1127	292	2052	X	6016.329.038
1:5	540	68	50	900	180	2700	X	6016.329.050

PESO INDICATIVO APPROXIMATE WEIGHT GEWICHT CA.	OLIO CONSIGLIATO RECOMMENDED OIL EMPFOHLENES ÖL	MATERIALI MATERIALS WERKSTOFF			CUSCINETTI BEARINGS NADELLAGER				
		SCATOLA CASE GEHAUSE	ALBERI SHAFTS WELLEN	INGRANAGGI GEARS VERZÄHNUNG	A	B	C	D	E
Kg.	SAE 90 Kg.								
37	2,5	G 25	20MnCr5	20MnCr5	6308	6307	6307	6308	

SCATOLE PER POMPE OLEODINAMICHE GEARBOX FOR HYDRAULIC GEAR PUMPS GETRIEBE FÜR ÖLKRAFTZAHNRADERPUMPEN

M10

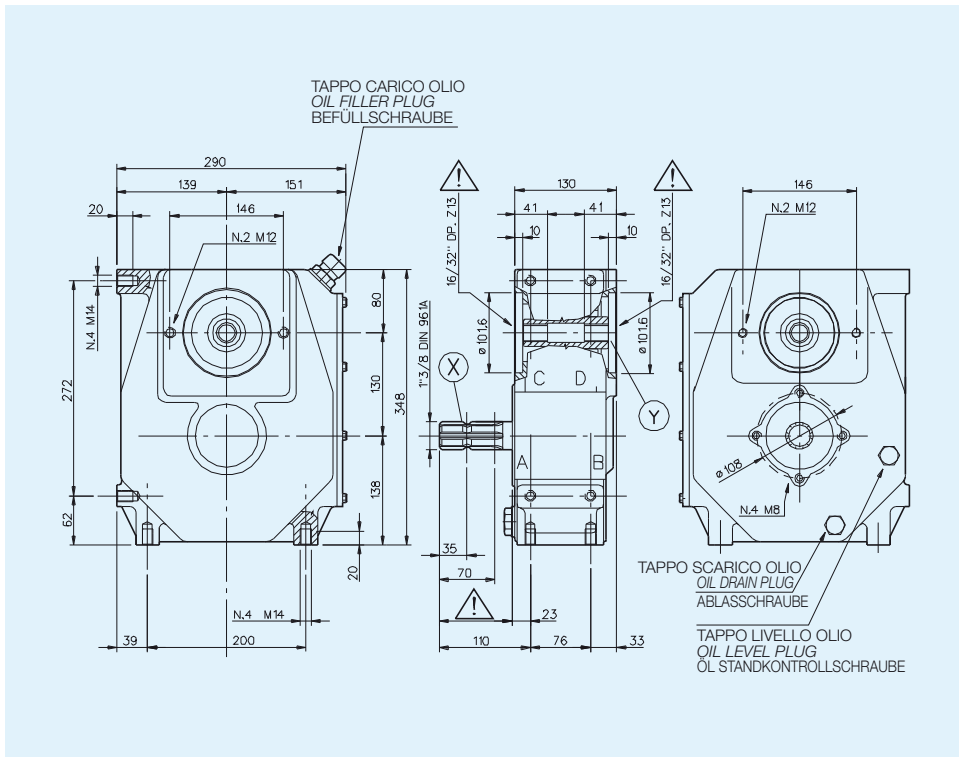

RAPPORTO RATIO VERHÄLTNIS	ENTRATA INPUT EINGANG		USCITA OUTPUT AUSGANG			MONTAGGIO ARRANGEMENT MONTAGE	ENTRATA INPUT EINGANG	CODICE CODE BESTELLNUMMER
	giri/min r.p.m. U/min. min ⁻¹	POTENZA POWER LEISTUNG CV kW	COPPIA TORQUE DREHEM N·m	COPPIA TORQUE DREHEM N·m	giri/min r.p.m. U/min. min ⁻¹			
1:1	540	85 62.5	1127	1112	540		X/Y	6016.327.010
1:2.5	1000	125 91.9	895	355	2500		X	6016.327.025
1:3.8	540	85 62.5	1127	292	2052		X	6016.327.038
1:5	540	80 58.8	1061	209	2700		X	6016.327.050

PESO INDICATIVO APPROXIMATE WEIGHT GEWICHT CA.	OLIO CONSIGLIATO RECOMMENDED OIL EMPFOHLENES ÖL	MATERIALI MATERIALS WERKSTOFF			CUSCINETTI BEARINGS NADELLAGER				
		SCATOLA CASE GEHAUSE	ALBERI SHAFTS WELLEN	INGRANAGGI GEARS VERZÄHNUNG	A	B	C	D	E
kg									
33	SAE 90 kg 2	G22	20MnCr5	20MnCr5	6308	6307	6308	6308	

SCATOLE PER POMPE OLEODINAMICHE GEARBOX FOR HYDRAULIC GEAR PUMPS GETRIEBE FÜR ÖLKRAFTZAHNRADERPUMPEN

M10

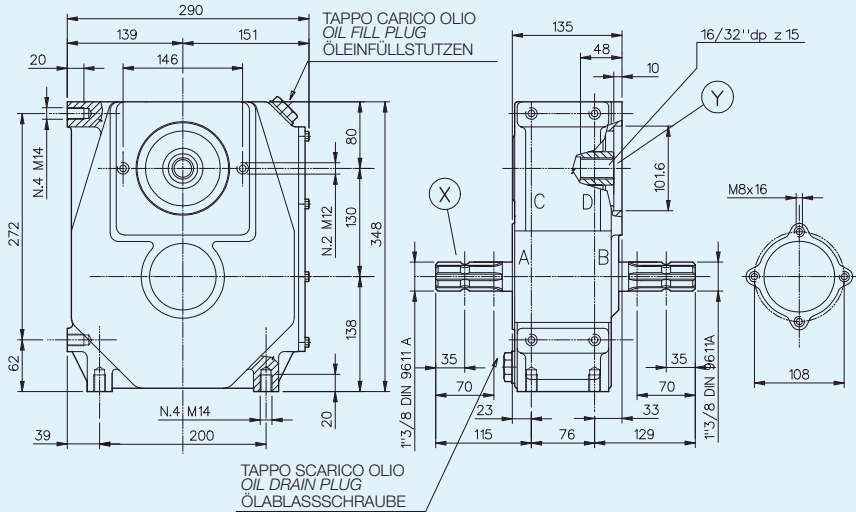

RAPPORTO RATIO VERHÄLTNIS	ENTRATA INPUT EINGANG		USCITA OUTPUT AUSGANG		MONTAGGIO ARRANGEMENT MONTAGE	ENTRATA INPUT EINGANG	CODICE CODE BESTELLNUMMER
	giri/min r.p.m. U/min. min ⁻¹	POTENZA POWER LEISTUNG CV kW	COPPIA TORQUE DREHEM N·m	COPPIA TORQUE DREHEM N·m			
1:2	540	90 66	1193	589		X	6016.334.020
1:3	540	85 62,5	1127	360		X	6016.334.030
1:2.5	540	85 62,5	1127	445		X	6016.334.025
1:2.5	1000	125 91,9	895	353		X	6016.334.025
1:3	540	85 62,5	1127	360		X	6016.334.030

PESO INDICATIVO APPROXIMATE WEIGHT GEWICHT CA.	OLIO CONSIGLIATO RECOMMENDED OIL EMPFOHLENES ÖL	MATERIALI MATERIALS WERKSTOFF			CUSCINETTI BEARINGS NADELLAGER				
		SCATOLA CASE GEHAUSE	ALBERI SHAFTS WELLEN	INGRANAGGI GEARS VERZÄHNUNG	A	B	C	D	E
kg									
32	SAE 90 kg 2.5	G22	20MnCr5	20MnCr5	6308	6307	6307	6308	

SCATOLE PER POMPE OLEODINAMICHE GEARBOX FOR HYDRAULIC GEAR PUMPS GETRIEBE FÜR ÖLKRAFTZAHNRADERPUMPEN

M10

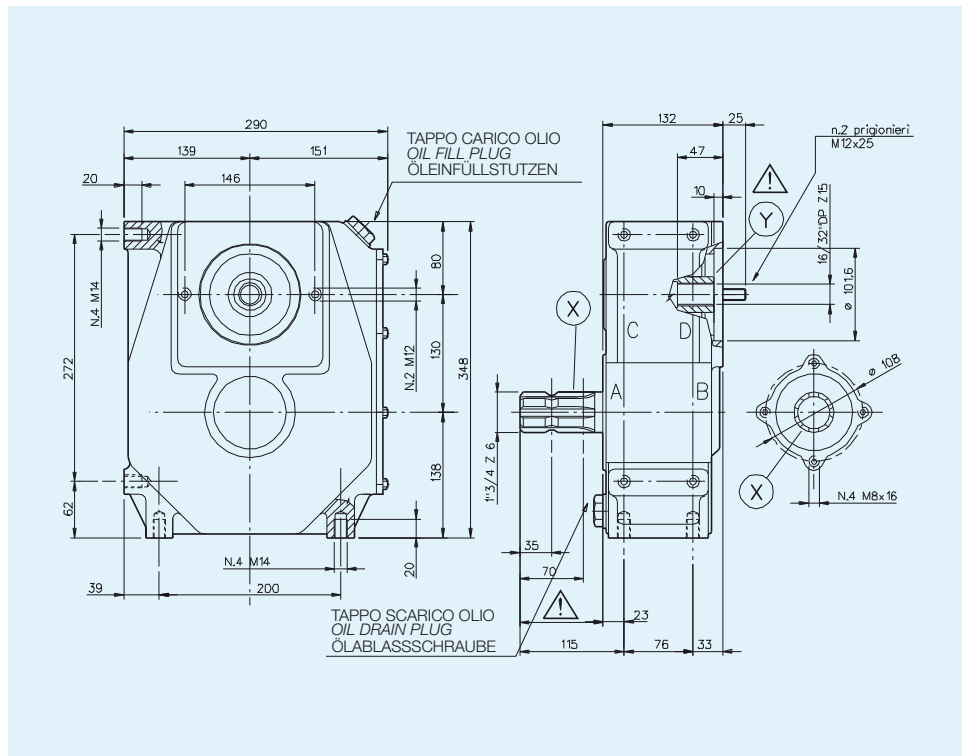

RAPPORTO RATIO VERHÄLTNIS	ENTRATA INPUT EINGANG		USCITA OUTPUT AUSGANG		MONTAGGIO ARRANGEMENT MONTAGE	ENTRATA INPUT EINGANG	CODICE CODE BESTELLNUMMER
	giri/min r.p.m. U/min. min ⁻¹	POTENZA POWER LEISTUNG CV kW	COPPIA TORQUE DREHEM N-m	COPPIA TORQUE DREHEM N-m			
1:2	540	90 66	1193	589		X	6016.356.020
1:3.8	540	85 62.5	1127	292		2052	X

PESO INDICATIVO APPROXIMATE WEIGHT GEWICHT CA.	OLIO CONSIGLIATO RECOMMENDED OIL EMPFOHLENES ÖL	MATERIALI MATERIALS WERKSTOFF			CUSCINETTI BEARINGS NADELLAGER				
		SCATOLA CASE GEHAUSE	ALBERI SHAFTS WELLEN	INGRANAGGI GEARS VERZÄHNUNG	A	B	C	D	E
kg									
32	SAE 90 kg 2.5	G22	20MnCr5	20MnCr5	6308	6307	6307	6308	

SCATOLE PER POMPE OLEODINAMICHE GEARBOX FOR HYDRAULIC GEAR PUMPS GETRIEBE FÜR ÖLKRAFTZAHNRADERPUMPEN

BR4

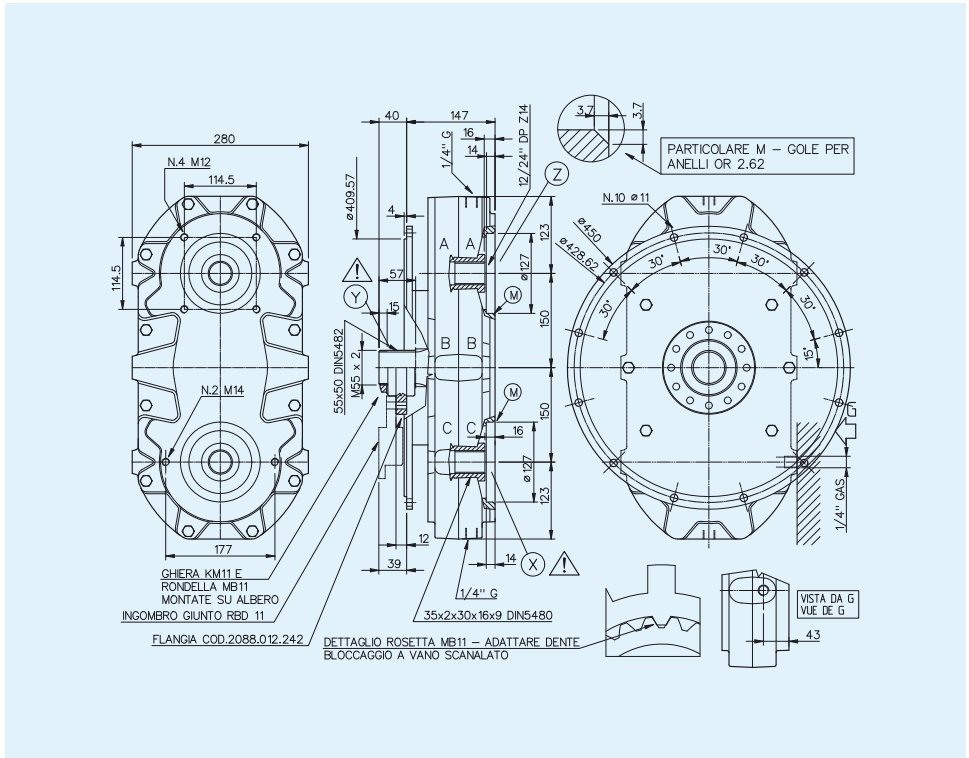

RAPPORTO RATIO VERHÄLTNIS	ENTRATA INPUT EINGANG		USCITA OUTPUT AUSGANG		MONTAGGIO ARRANGEMENT MONTAGE	ENTRATA INPUT EINGANG	CODICE CODE BESTELLNUMMER
	giri/min r.p.m. U/min. min ⁻¹	POTENZA POWER LEISTUNG CV kW	COPPIA TORQUE DREHEM N·m	COPPIA TORQUE DREHEM N·m			
1:1	2300	130 95.5	400	400		Y	6088.300.010

PESO INDICATIVO APPROXIMATE WEIGHT GEWICHT CA.	OLIO CONSIGLIATO RECOMMENDED OIL EMPFOHLENES ÖL	MATERIALI MATERIALS WERKSTOFF			CUSCINETTI BEARINGS NADELLAGER				
		SCATOLA CASE GEHAUSE	ALBERI SHAFTS WELLEN	INGRANAGGI GEARS VERZÄHNUNG	A	B	C	D	E
kg		G25	20MnCr5	20MnCr5	6212	6212	6212		
60	SAE 90 kg 3.5								

SCATOLE PER POMPE OLEODINAMICHE GEARBOX FOR HYDRAULIC GEAR PUMPS GETRIEBE FÜR ÖLKRAFTZAHNRADERPUMPEN

BR4

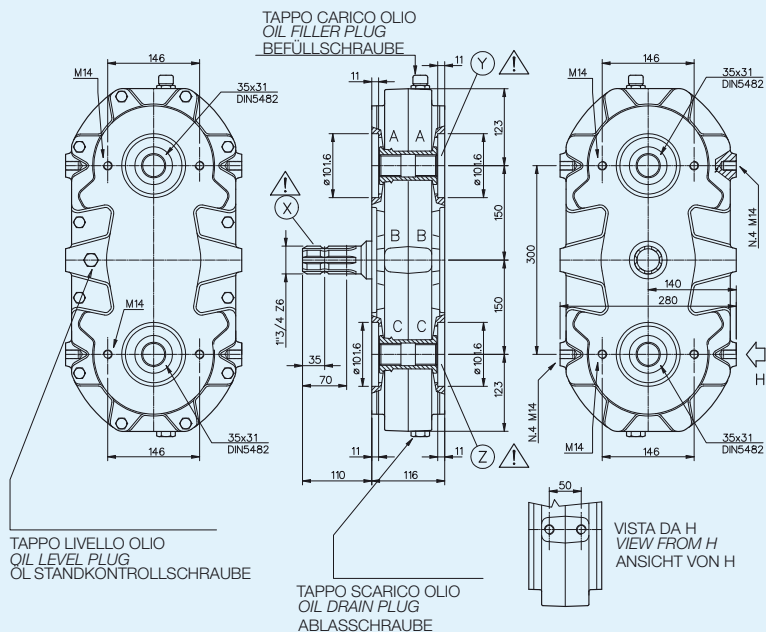

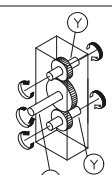
RAPPORTO RATIO VERHALTNIS	ENTRATA INPUT EINGANG		USCITA OUTPUT AUSGANG			MONTAGGIO ARRANGEMENT MONTAGE	ENTRATA INPUT EINGANG	CODICE CODE BESTELLNUMMER
	giri/min r.p.m. U/min. min ⁻¹	POTENZA POWER LEISTUNG CV kW	COPPIA TORQUE DREHEM N·m	COPPIA TORQUE DREHEM N·m	giri/min r.p.m. U/min. min ⁻¹			
1:1.5	1000	115 84.5	808	517	1500		X	6088.302.015

PESO INDICATIVO APPROXIMATE WEIGHT GEWICHT CA.	OLIO CONSIGLIATO RECOMMENDED OIL EMPFOHLENES ÖL	MATERIALI MATERIALS WERKSTOFF			CUSCINETTI BEARINGS NADELLAGER				
		SCATOLA CASE GEHAUSE	ALBERI SHAFTS WELLEN	INGRANAGGI GEARS VERZÄHNUNG	A	B	C	D	E
kg									
63	SAE 90 kg 3.5	G25	20MnCr5	20MnCr5	6212	6212	6212		

SCATOLE PER POMPE OLEODINAMICHE GEARBOX FOR HYDRAULIC GEAR PUMPS GETRIEBE FÜR ÖLKRAFTZAHNRADERPUMPEN

BR4

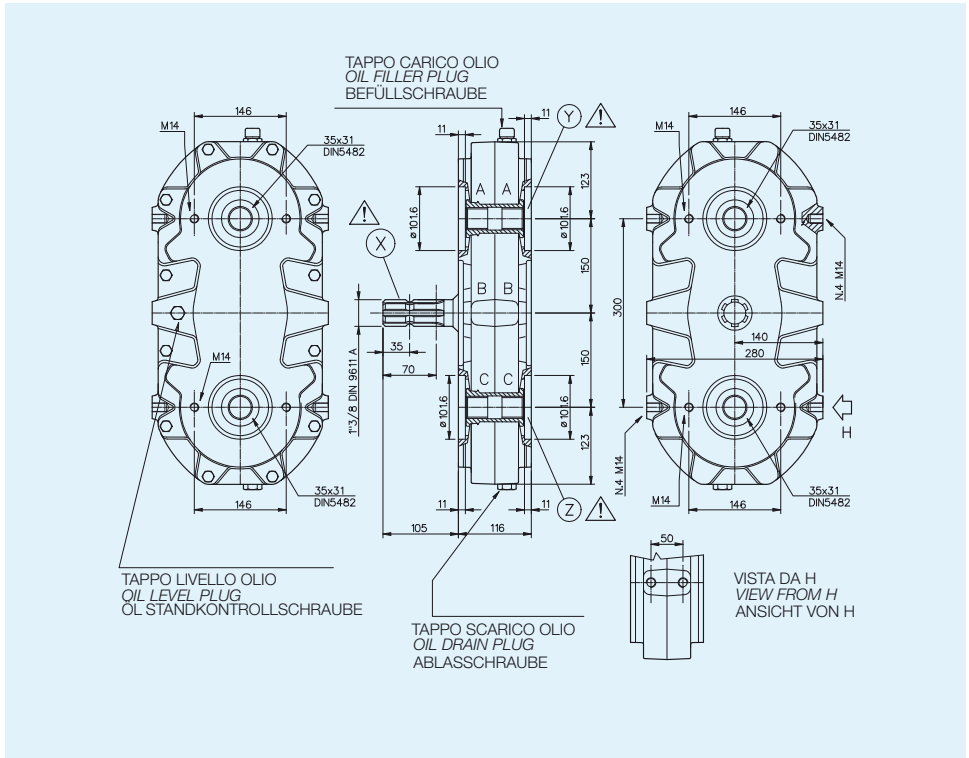

RAPPORTO RATIO VERHÄLTNIS	ENTRATA INPUT EINGANG		USCITA OUTPUT AUSGANG		MONTAGGIO ARRANGEMENT MONTAGE	ENTRATA INPUT EINGANG	CODICE CODE BESTELLNUMMER
	giri/min r.p.m. U/min. min ⁻¹	POTENZA POWER LEISTUNG CV kW	COPPIA TORQUE DREHEM N·m	COPPIA TORQUE DREHEM N·m			
1:1.5	1000	115 84.5	808	517		X	6088.309.015
1:3	1000	204 150	1433	470		3000	X

PESO INDICATIVO APPROXIMATE WEIGHT GEWICHT CA.	OLIO CONSIGLIATO RECOMMENDED OIL EMPFOHLENES ÖL	MATERIALI MATERIALS WERKSTOFF			CUSCINETTI BEARINGS NADELLAGER				
		SCATOLA CASE GEHAUSE	ALBERI SHAFTS WELLEN	INGRANAGGI GEARS VERZÄHNUNG	A	B	C	D	E
kg									
63	SAE 90 kg 3.5	G25	20MnCr5	20MnCr5	6212	6212	6212		

SCATOLE PER POMPE OLEODINAMICHE GEARBOX FOR HYDRAULIC GEAR PUMPS GETRIEBE FÜR ÖLKRAFTZAHNRADERPUMPEN

BR4

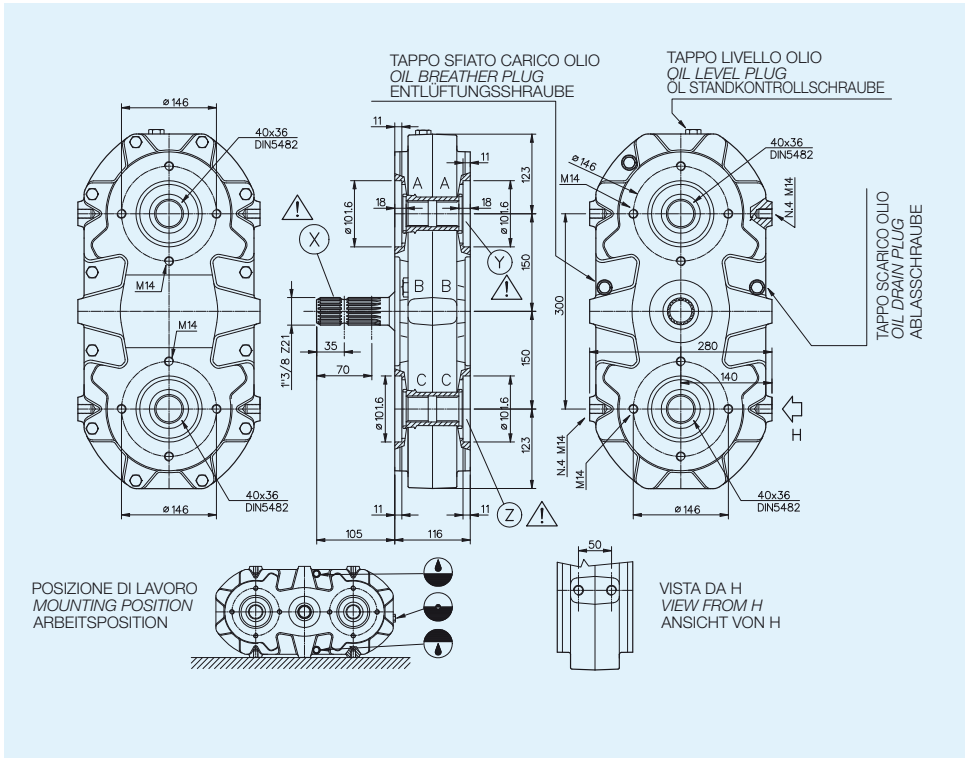

RAPPORTO RATIO VERHALTNIS	ENTRATA INPUT EINGANG		USCITA OUTPUT AUSGANG			MONTAGGIO ARRANGEMENT MONTAGE	ENTRATA INPUT EINGANG	CODICE CODE BESTELLNUMMER
	giri/min r.p.m. U/min. min ⁻¹	POTENZA POWER LEISTUNG CV kW	COPPIA TORQUE DREHEM N·m	COPPIA TORQUE DREHEM N·m	giri/min r.p.m. U/min. min ⁻¹			
1:1.5	1000	115 84.5	808	517	1500		X	6088.310.015
1:2	1000	136 100	955	459	2000		X	6088.310.020

PESO INDICATIVO APPROXIMATE WEIGHT GEWICHT CA.	OLIO CONSIGLIATO RECOMMENDED OIL EMPFOHLENES ÖL	MATERIALI MATERIALS WERKSTOFF			CUSCINETTI BEARINGS NADELLAGER					
		SCATOLA CASE GEHAUSE	ALBERI SHAFTS WELLEN	INGRANAGGI GEARS VERZÄHNUNG	A	B	C	D	E	
kg										
67	SAE 90 kg 3.5	G 25	20MnCr5	20MnCr5	6212	6212	6212			

SCATOLE PER POMPE OLEODINAMICHE GEARBOX FOR HYDRAULIC GEAR PUMPS GETRIEBE FÜR ÖLKRAFTZAHNRADERPUMPEN

BR4

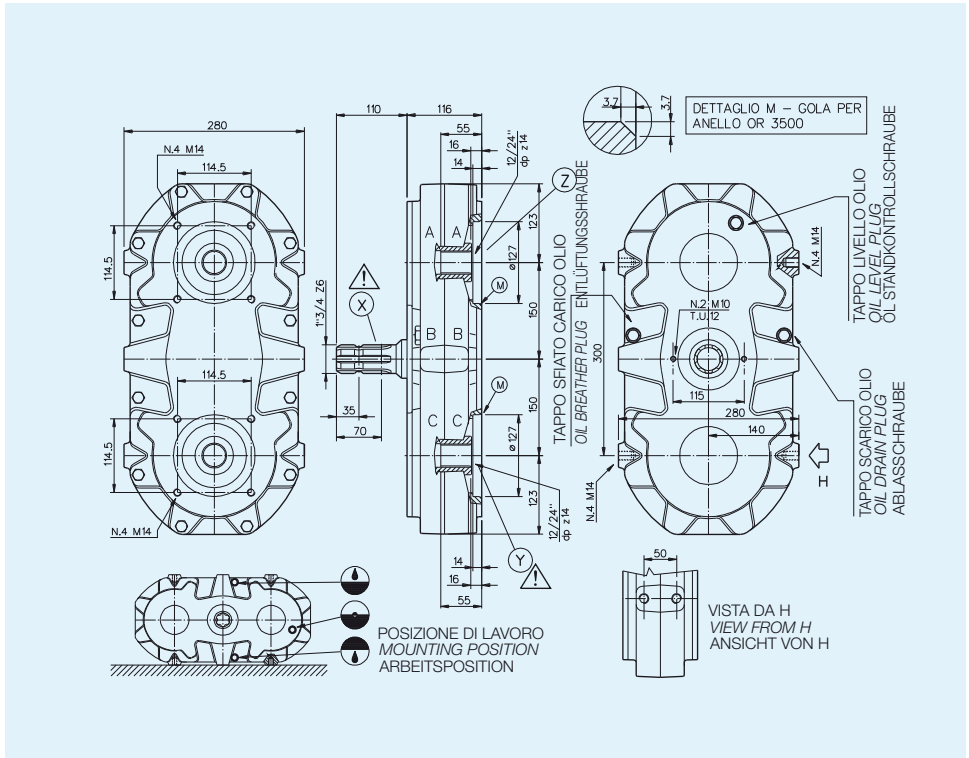

RAPPORTO RATIO VERHALTNIS	ENTRATA INPUT EINGANG		USCITA OUTPUT AUSGANG		MONTAGGIO ARRANGEMENT MONTAGE	ENTRATA INPUT EINGANG	CODICE CODE BESTELLNUMMER
	giri/min r.p.m. U/min. min ⁻¹	POTENZA POWER LEISTUNG CV kW	COPPIA TORQUE DREHEM N·m	COPPIA TORQUE DREHEM N·m			
1:3	1000	204 150	1433	302		X	6088.317.030
1:3	1000	204 150	1433	175		3000	X

PESO INDICATIVO APPROXIMATE WEIGHT GEWICHT CA.	OLIO CONSIGLIATO RECOMMENDED OIL EMPFOHLENES ÖL	MATERIALI MATERIALS WERKSTOFF			CUSCINETTI BEARINGS NADELLAGER				
		SCATOLA CASE GEHAUSE	ALBERI SHAFTS WELLEN	INGRANAGGI GEARS VERZÄHNUNG	A	B	C	D	E
kg									
66	SAE 90 kg 3.5	G25	20MnCr5	20MnCr5	6212	6212	6212		

SCATOLE PER POMPE OLEODINAMICHE GEARBOX FOR HYDRAULIC GEAR PUMPS GETRIEBE FÜR ÖLKRAFTZAHNRADERPUMPEN

BR5

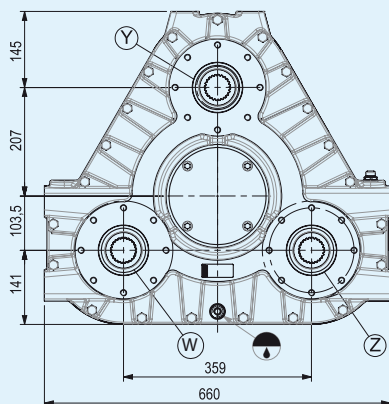

PREDISPOSIZIONI SAE A, SAE B, SAE C
PUMP ADAPTER SIZE SAE A, SAE B, SAE C
SAE A, SAE B, SAE C BAUART

CUSCINETTI DI MARCA PRIMARIA
HIGH QUALITY BRAND BEARINGS
HOCHWERTIGE LAGER

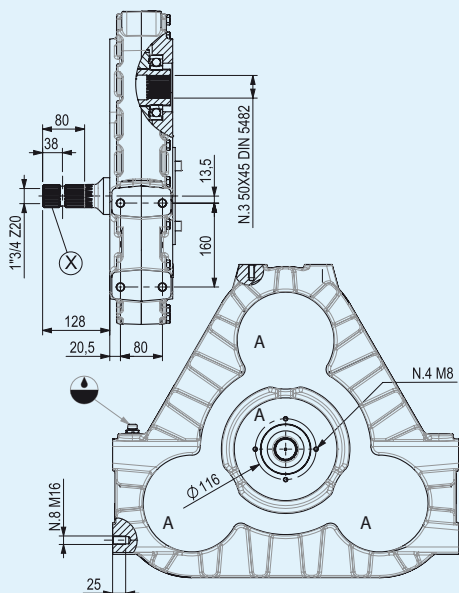

RAPPORTO RATIO VERHALTNIS	ENTRATA INPUT EINGANG		USCITA OUTPUT AUSGANG		MONTAGGIO ARRANGEMENT MONTAGE	ENTRATA INPUT EINGANG	CODICE CODE BESTELLNUMMER
	giri/min r.p.m. U/min. min ⁻¹	POTENZA POWER LEISTUNG CV kW	COPPIA TORQUE DREHEM N·m	COPPIA TORQUE DREHEM N·m			
1:2	1000	330 242	2318	Y-386 W-386 Z-386	2000	X	6141.001.020

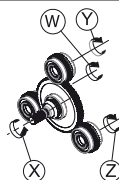

PESO INDICATIVO APPROXIMATE WEIGHT GEWICHT CA.	OLIO CONSIGLIATO RECOMMENDED OIL EMPFOHLENES ÖL	MATERIALI MATERIALS WERKSTOFF			CUSCINETTI BEARINGS NADELLAGER				
		SCATOLA CASE GEHAUSE	ALBERI SHAFTS WELLEN	INGRANAGGI GEARS VERZÄHNUNG	A	B	C	D	E
kg		G 25	20MnCr5	20MnCr5	6214				
140	ISO VG 150-320								

SCATOLE PER POMPE OLEODINAMICHE GEARBOX FOR HYDRAULIC GEAR PUMPS GETRIEBE FÜR ÖLKRAFTZAHNRADERPUMPEN

BR5

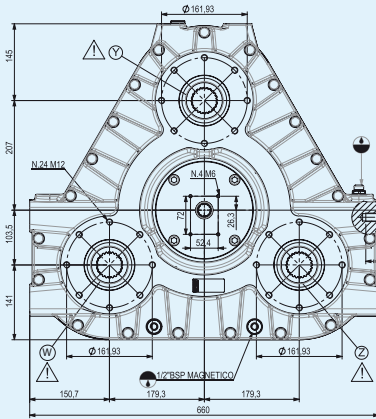

ENTRATA PER CIRCUITO DI RAFFREDDAMENTO
EXTERNAL COOLING SYSTEM INLET
EINGANG FÜR KÜHLSYSTEM



USCITA PER CIRCUITO DI RAFFREDDAMENTO
EXTERNAL COOLING SYSTEM OUTLET
AUSGANG FÜR KÜHLSYSTEM

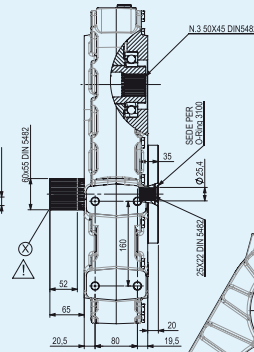

PREDISPOSIZIONI
SAE B, SAE C, SAE D
PUMP ADAPTER SIZE
SAE B, SAE C, SAE D
SAE B, SAE C, SAE D
BAUART

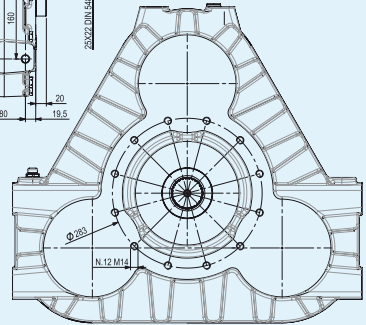

PREDISPOSIZIONI SAE 1, SAE 2, SAE 3
PUMP ADAPTER SIZE SAE 1, SAE 2, SAE 3
SAE 1, SAE 2, SAE 3 BAUART

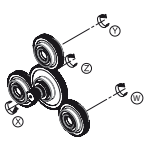
RAPPORTO RATIO VERHÄLTNIS	ENTRATA INPUT EINGANG		COPPIA MAX. OGNI USCITA MAX TORQUE EACH OUTPUT MAX DREHMOMENT FÜR JEDEN AUSGANG		MONTAGGIO ARRANGEMENT MONTAGE	ENTRATA INPUT EINGANG	CODICE CODE BESTELLNUMMER
	giri/min r.p.m. U/min. min ⁻¹	POTENZA POWER LEISTUNG CV kW	COPPIA TORQUE DREHEM N·m	N·m			
1:1.3	2000	330 242	1160	910		X	6141.014.013

PESO INDICATIVO APPROXIMATE WEIGHT GEWICHT CA.	OLIO CONSIGLIATO RECOMMENDED OIL EMPFOHLENES ÖL	MATERIALI MATERIALS WERKSTOFF			CUSCINETTI BEARINGS NADELLAGER					
		SCATOLA CASE GEHAUSE	ALBERI SHAFTS WELLEN	INGRANAGGI GEARS VERZÄHNUNG	A	B	C	D	E	
kg 145	ISO VG 150-320 4 LT.	G 25	20MnCr5	20MnCr5	6214					

SCATOLE PER POMPE OLEODINAMICHE GEARBOX FOR HYDRAULIC GEAR PUMPS GETRIEBE FÜR ÖLKRAFTZAHNRADERPUMPEN

BR6

PREDISPOSIZIONI
SAE B, SAE C, SAE D
profil scanalati 50x45
DIN 5482

PUMP ADAPTER SIZE
SAE B, SAE C, SAE D
splined profiles 50x45
DIN 5482

SAE B, SAE C, SAE D
BAUART
keilwellen 50x45
DIN 5482

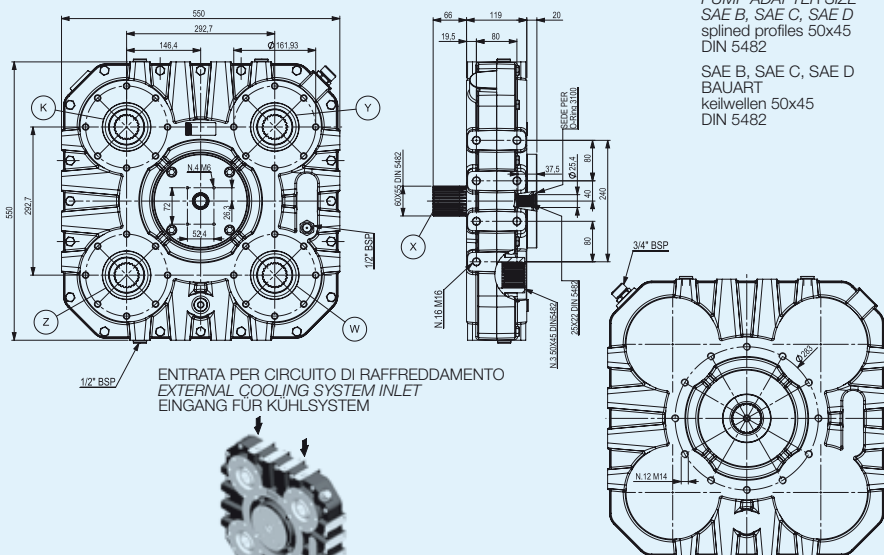

ENTRATA PER CIRCUITO DI RAFFREDDAMENTO
EXTERNAL COOLING SYSTEM INLET
EINGANG FÜR KÜHLSYSTEM

USCITA PER CIRCUITO
DI RAFFREDDAMENTO
EXTERNAL COOLING SYSTEM OUTLET
AUSGANG FÜR KÜHLSYSTEM

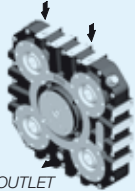

PREDISPOSIZIONI SAE 1, SAE 2, SAE 3
PUMP ADAPTER SIZE SAE 1, SAE 2, SAE 3
SAE 1, SAE 2, SAE 3 BAUART

RAPPORTO RATIO VERHALTNIS	ENTRATA INPUT EINGANG		USCITA OUTPUT AUSGANG		MONTAGGIO ARRANGEMENT MONTAGE	ENTRATA INPUT EINGANG	CODICE CODE BESTELLNUMMER
	giri/min r.p.m. U/min. min ⁻¹	POTENZA POWER LEISTUNG CV kW	COPPIA TORQUE DREHEM N·m	COPPIA TORQUE DREHEM N·m			
1:2	1000	330 242	2318	Y-386 W-386 Z-386	2000	X	6141.001.020

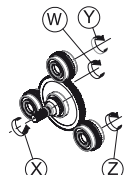

PESO INDICATIVO APPROXIMATE WEIGHT GEWICHT CA.	OLIO CONSIGLIATO RECOMMENDED OIL EMPFOHLENES ÖL	MATERIALI MATERIALS WERKSTOFF			CUSCINETTI BEARINGS NADELLAGER				
		SCATOLA CASE GEHAUSE	ALBERI SHAFTS WELLEN	INGRANAGGI GEARS VERZÄHNUNG	A	B	C	D	E
kg 140	ISO VG 150-320	G 25	20MnCr5	20MnCr5	6214				