

Open circuit axial piston pumps and motors

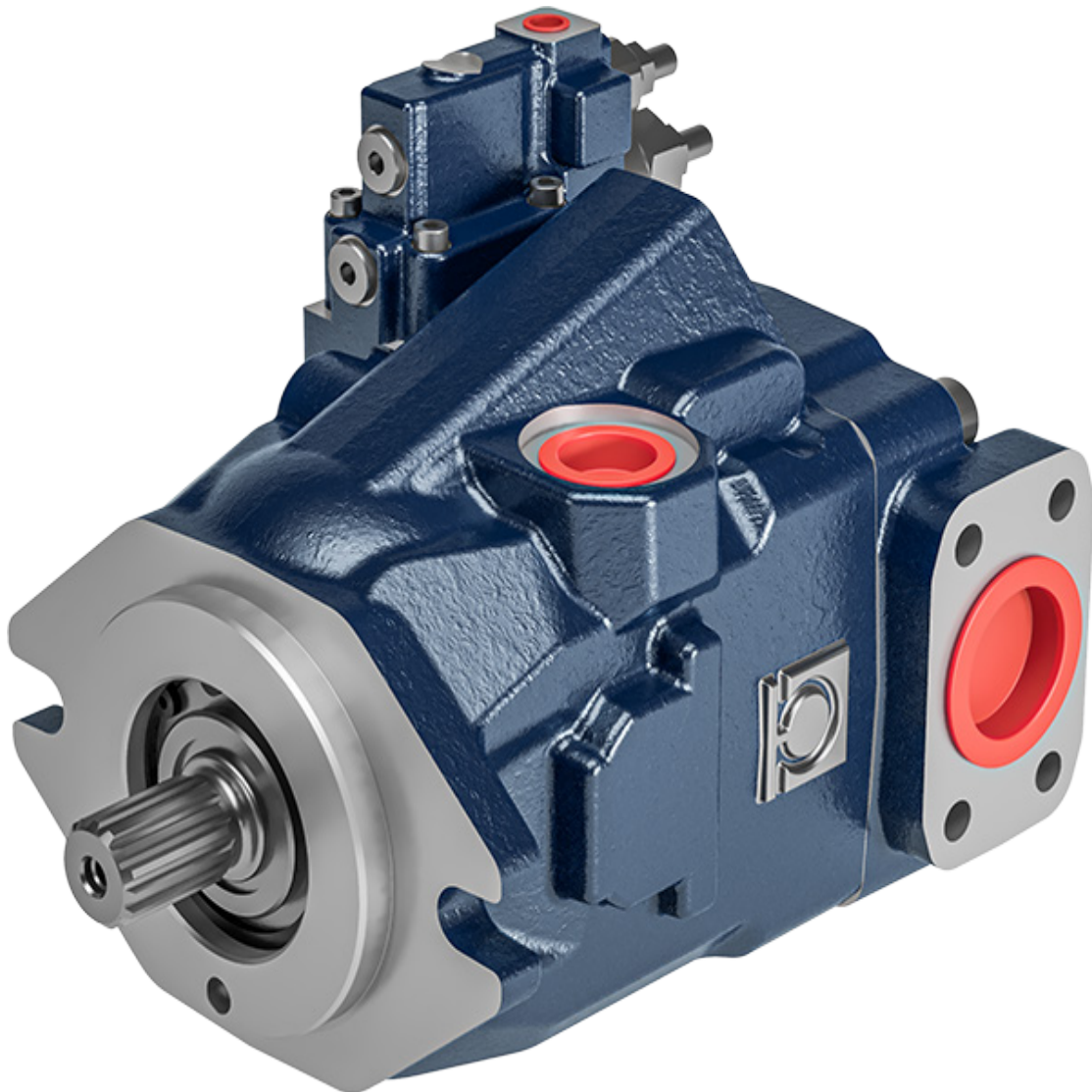

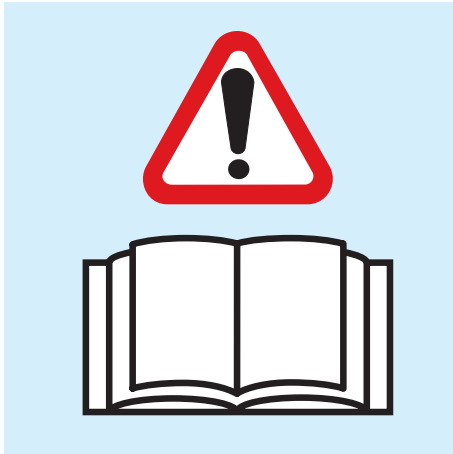

This manual contains instructions for installing and operating open circuit axial piston pumps. The following instructions apply to standard products.

Due to the constant technological research that aims to improve the technical specifications of our products, Bondioli & Pavesi reserves the right to modify its products and internal calibration and testing procedures without prior notice and/or official changes being made. For this reason, this material shall not constitute a basis for legal proceedings.

Bondioli & Pavesi may not be held liable for faults, incidents or modifications caused by a failure to comply with the instructions in this manual and a failure to comply with the safety standards in force, even if not included in this manual.

Bondioli & Pavesi may not be held liable for any errors in this manual; if in doubt, please contact our head office for more information.

Failure to observe these instructions shall render the manufacturer's warranty automatically null and void.

This catalogue may not be reproduced, even partially, without specific authorisation in writing from Bondioli & Pavesi. This catalogue replaces all previous versions.

| | | |
|-------------------------------|---|----|
| Installation | General instructions | 4 |
| | Transport and storage | 4 |
| | Installation position | 6 |
| | Pipes and fittings | 6 |
| | Definition of pressures | 7 |
| | Temperature | 8 |
| | Cleaning | 8 |
| | Type of oil | 8 |
| | Couplings | 8 |
| Start-up | Precautions to be taken before start-up | 9 |
| | Filling | 9 |
| | System start-up | 9 |
| Troubleshooting | Introduction | 10 |
| | Tables | 10 |
| Maintenance and checks | Routine maintenance | 12 |
| | Special maintenance | 12 |
| | Efficiency checks | 12 |
| | Checking distributor plate | 13 |
| | Checking cylinder block | 13 |
| | Checking pistons and shoes | 13 |
| | Checking shoe retainer plate | 13 |
| | Checking half ball | 13 |
| | Checking swash plate | 13 |
| | Checking distributor bushing | 14 |
| | Checking shaft and bearing | 14 |
| | Checking servo-control | 14 |
| | Labelling | 14 |
| | Protection of oil ports | 14 |
| | Protection of components | 14 |
| | Painting | 15 |

General instructions To ensure that Bondioli & Pavesi components operate correctly, the following recommendations must be observed during design and installation.

Transport and storage Depending on the weight and duration of transport (dimensions and weights can be found in the product specifications sheet or technical drawing), the following transport options are available:

Manual transport Bondioli & Pavesi pumps weighing up to 15 kg can be transported manually for a short period of time if necessary.

Warning!



Manual transport may be harmful to health.

Use personal protective equipment (e.g., safety glasses, gloves, suitable work clothing, safety footwear).

Avoid moving pumps with sensitive accessories (e.g., sensors or valves) manually.

Transportation with lifting device

Axial piston units can be transported by connecting them to a lifting device, i.e. eye bolts or lifting straps.

The axial piston unit may be transported suspended from an eye bolt screwed into the drive shaft, provided it is moved from the outside; this transport option results in axial forces being applied.

Use eye bolts of the correct thread and size (the thread size is indicated in the technical drawing).

Make sure that the eye bolt is capable of supporting the total weight of the axial piston unit plus 20%.

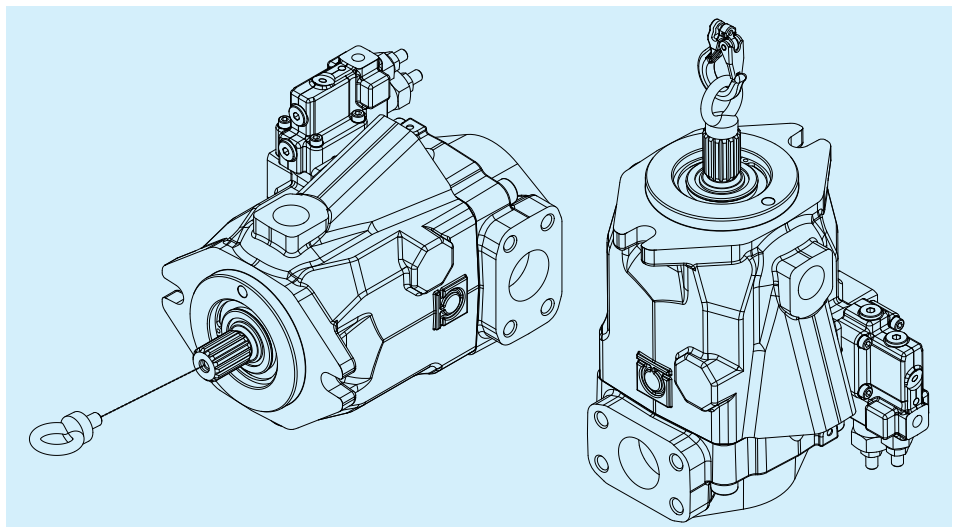

Transportation with lifting belt
Warning!

Suspended loads. When being transported with a lifting device, the axial piston unit may slip out of the lifting strap and cause injury.

Use the widest possible lifting strap.

Make sure that the lifting strap is securely attached to the axial piston unit.

Only guide the axial piston unit by hand when it is necessary to make fine adjustments to its position or to prevent rocking.

Do not stand or place your hands under suspended loads.

Place the lifting strap around the piston unit without passing over the fastening elements (e.g., valves) or other accessories.

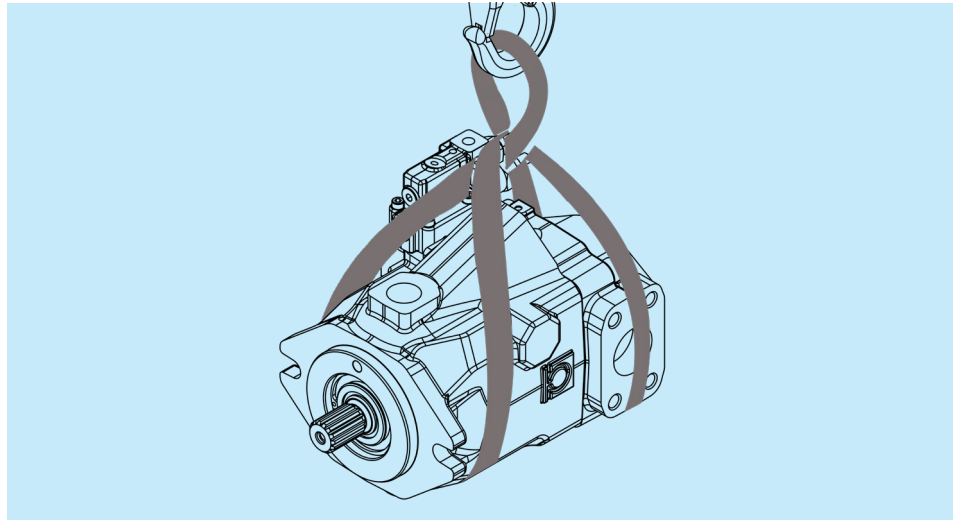

Storage

The storage areas must be free of corrosive materials and gases. To avoid damaging the seals, do not use equipment that may release ozone gases (e.g., mercury vapour lamps, high voltage equipment, electric motors, sources of electrical sparks or discharges) in the storage areas. The storage areas must be completely from humidity.

The ideal storage temperature is between +5 °C and +20 °C (minimum storage temperature -50 °C, except for units that have electronic components; maximum storage temperature +60 °C).

Avoid exposing the piston units to high levels of light irradiation (e.g. bright windows or direct fluorescent lighting).

Do not stack the axial piston units, and protect them from knocks.

Do not store the axial piston units on the drive shaft or accessories (e.g. sensors).

Check the axial piston units once a month to ensure they are stored correctly. The axial piston units are supplied by the manufacturer with anti-corrosion packaging.

An axial piston unit can be stored for a maximum of 12 months with standard protection or a maximum of 24 months with corrosion protection.

The warranty will no longer be valid if the storage requirements and conditions are not complied with or the maximum period of storage has expired.

Procedure to be followed after the maximum period of storage has expired

- Check the entire axial piston unit for damage and corroded areas before installation.
- Perform a test run to check that the axial piston unit operates correctly.
- If stored for over 24 months, the shaft seal must be replaced.

When the maximum storage period expires, or if you have questions regarding repair work or spare parts, contact the Bondioli & Pavesi customer service. The instructions below refer to axial piston units that use mineral oil-based hydraulic fluid. Other hydraulic fluids require specific methods of storage.

Bondioli & Pavesi recommends the following procedure:

- Empty and clean the axial piston unit.
- For storage periods of up to 12 months, coat the inside of the axial piston unit with mineral oil and fill with approximately 100 ml of mineral oil.
- For storage periods of up to 24 months, fill the axial piston unit with a VCI 329 corrosion inhibitor (20 ml). The unit is filled via the reservoir port.
- Seal all the oil ports.
- Moisten the painted surfaces of the axial piston unit with mineral oil or an easily removable corrosion protection agent, e.g., acid-free grease.
- Wrap all the oil ports on the axial piston unit in protective anti-corrosion film and store the unit where it is protected from knocks.

Installation position

When assembling the component and the drain pipes, make sure they are in a position in which the internal parts remain lubricated by the oil during long periods of machine shutdown.

The oil level of the reservoir should be higher than that of the pump to prevent cavitation and facilitate pump suction.

The horizontal position is preferable for the piston unit.

If this is not possible, the difference between the reservoir oil level and the pump MUST NOT exceed 0.5 m.

When placing the component on the machine, make sure that its parts do not obstruct the movement of the adjustment screws and parts on the pump when in operation.

Pipes/Hoses and fittings

The pipes/hoses that connect the pump to the hydraulic circuit must be able to withstand the required operating pressure. Sharp bends in the pipes/hoses should be avoided.

Banjo fittings should not be used.

The pipe/hose cross section must also be sufficiently large enough to maintain the fluid velocity within acceptable limits:

DELIVERY PIPES/HOSES:

5 m/sec MAX

RETURN, DRAIN PIPES/HOSES:

3 m/sec MAX

SUCTION PIPES/HOSES:

1.5 m/sec MAX

The following simplified formula can be used to calculate the fluid velocity:

$$v = \frac{Q \times 21.2}{d^2}$$

where:

v = fluid velocity (m/sec)

Q = fluid flow rate (l/min)

d = inner diameter of pipe /hose (mm)

Suction Pump suction must use a pipe/hoses that can withstand vacuums; sharp bends, blockages and excessive lengths should be avoided. Check that there is a suction pressure of at least 0.8 bar (absolute value) in the axial piston unit.

Checking Check that, at maximum pump speed, the vacuum during suction does not exceed 0.5 bar with cold oil and 0.2 bar with oil at working temperature (50-70 °C).

Drain line The drain line must be installed in a position that guarantees that the pump is filled, even if the system is shut down for a long period of time. The drain line must be left as free as possible to discharge into the reservoir.

Do not connect the drain line of other hydraulic components to the drain line of the Bondioli & Pavesi components.

Warning!



The pressure on the drain line must not exceed 2 bar, for higher pressures contact the technical sales department.

Definition of pressures

The service life of a pump depends on a number of parameters: the speed, the pressure it is subjected to as well as the operating temperature, the degree of contamination, the viscosity of the oil and the work cycle.

In any case, it should be stressed that high pressures resulting from high loads decrease the service life of the pump.

For this reason, special attention should be paid to the pressure levels specified in the catalogue.

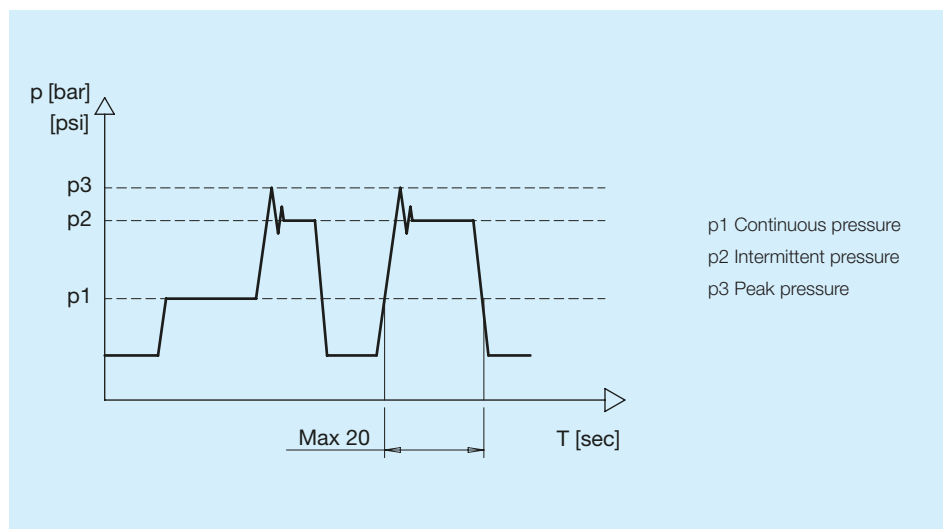

A satisfactory service life of a pump should coincide with the recognized warranty period (1500 hours of use).

The pressures P1 (continuous pressure), P2 (intermittent pressure) and P3 (peak pressure) indicated in the catalogue can be defined as follows:

- P1 (continuous pressure) is the maximum operating pressure that guarantees the 1500 hour duration of the pump. The product should operate below or at the continuous pressure value.
- P2 (intermittent pressure) is the maximum intermittent pressure, pressure that can be maintained for short periods (max 20 continuous seconds). The sum of the periods in which P2 is reached can be in total 10% of the total service life of the pump, i.e. 150 hours. Between two periods of use under intermittent pressure, a pressure value must be passed that coincides with or is less than the continuous pressure value. The interval between 2 periods of use under intermittent pressure should be greater than or equal to 90 seconds. The P2 value generally coincides with the calibration value of the pressure relief valves on the pump.
- P3 (peak pressure) is the maximum peak pressure that can be maintained for short periods (max 0.1 seconds). The sum of the periods in which P3 is reached can be in total 0.1% of the total service life of the pump, i.e. 1.5 hours. Between two periods of use under peak pressure, a pressure value must be passed that coincides with or is less than

the P1 continuous pressure value. The interval between periods of use under peak pressure should be greater than or equal to 90 seconds. The P3 value generally coincides with the spike generated by the opening of the pressure relief valves on the pump. For particularly demanding applications with specific work cycles, we recommend requesting a calculation of the pump service life.

The data indicated in the catalogue refer to the standard product.

Temperature The temperature of the fluid in the reservoir must not exceed 80°C **for any reason whatsoever**; higher values may damage the components and lead to a rapid deterioration in performance.
To keep the temperature low:

- do not install the components near heat emitters (hot engines, mufflers, radiators, etc.).
 - use oil reservoirs having a minimum capacity of over 50 litres.
 - use adequately sized pipes/hoses
 - size the system heat exchanger adequately.
- Keep the radiating surfaces clean.



Suitable detectors should be installed that warn the operator when high temperatures are reached or interrupt machine operations to prevent overheating.

Cleaning Correct cleaning of all the system parts is essential and should be done before start-up.
The main connection operations should be performed in a clean, dust-free environment and debris of all types must be removed immediately before it enters the circuit.
Bondioli & Pavesi pumps are delivered with the ports closed by protective plugs, which **should only be removed** when the pump is connected.
When the component has been installed, it is good practice to add a small amount of hydraulic oil to protect the internal parts until the hydraulic system is filled.
Pickle the pipes and wash the hoses with suitable solvents.
Dry thoroughly with compressed air to remove all traces of solvent.

Type of oil Use pre-filtered, mineral oil-based hydraulic fluid containing antiwear and antifoam additives. Check that the fluid viscosity required for correct operating corresponds to the following specifications: minimum 10 mm²/s (for short periods), maximum 1000 mm²/s (for short periods at start-up), recommended viscosity 15-90 mm²/s.

The required contamination class is ISO 4406 20/18/15 (NAS 1638-9).

Couplings Bear in mind that no axial or radial load should be directly applied to the Bondioli & Pavesi pump or hydraulic motor shaft.
Always use suitable coupling joints that do not transmit loads to the shaft.

Precautions to be taken before start-up

Clean all the parts of the system that will come into contact with the circuit hydraulic fluid thoroughly (reservoir, pipes/hoses, heat exchangers, filters, etc.)

Make sure that nothing prevents normal suction of the pump (valves closed on the suction line, loose connections that could cause water to enter the pipes/hoses, etc.).

Pressure gauges must also be installed to check operating pressures.

Filling

When filling, use hydraulic fluid filtered at 10 micron to prevent foreign bodies entering the system. Even new hydraulic fluids may contain impurities.

It is essential to check that the reservoir has been cleaned carefully.

Fill the reservoir and the other large capacity components with fluid (filters, heat exchanger).

Fill the pump and hydraulic motor with oil using one of the drain ports and make sure that the case is at least 50% full.

System start-up

When the system starts up, all the air in the hydraulic circuit must be eliminated before the circuit is subjected to high stresses.

To do this, the machine transmission components must be able to rotate freely without load.

Warning!

Do not rotate the pump and the hydraulic motor unless the pump has been filled, as stated in the previous paragraph. The components may suffer serious damage.

Turn on the drive motor at the lowest possible speed, letting the axial piston unit turn with no loads applied; pay attention to any noises and leaks.

During this phase, check that the hydraulic fluid coming out of the pump reservoir does not contain bubbles.

Increase the speed, checking that the nominal pressure reaches the prescribed values; once the maximum pressure has been reached, check that the seals in the system are holding correctly.

Check the suction pressure and the maximum pressure of the hydraulic fluid on the drain port at the nominal speed, and at the prescribed swash plate tilt angle.

Introduction The components listed in this troubleshooting procedure may be inspected, adjusted, repaired or replaced according to the procedures outlined in this manual.

The information found in this section serves as a guide for identifying the causes of faults or malfunctions in the hydraulic components.

It is, therefore, a useful tool for eliminating problems that are easy to solve.

Experience has shown that we can divide the types of problem into a number of general cases.

These cases are listed in the tables below, which show, step by step, the checks that must be carried out and the adjustments that should be made, or parts that should be replaced.

| Fault | Possible cause | Solution |
|------------------------|---|-------------------------------------|
| The pump does not work | oil level in reservoir too low | top up oil level |
| | clogged or faulty filters | replace filter cartridges |
| | LS adjustment device faulty | repair or replace adjustment device |
| | solenoid valves faulty/ damaged | replace solenoid valves |
| | pressure relief valves faulty/ damaged | replace pressure relief valves |
| | damaged servo-control | repair or replace servo-control |
| | if the problem persists | contact Bondioli & Pavesi |

| Fault | Possible cause | Solution |
|------------------------|---|---|
| Poor system efficiency | clogged or faulty filters | replace filter cartridges |
| | pressure relief valves faulty/ damaged | replace pressure relief valves |
| | Inlet sized incorrectly | review inlet size |
| | system sized incorrectly | review system sizing |
| | oil temperature in circuit too high | see temperature section |
| | the oil is not within the optimal viscosity range | use a suitable type of oil |
| | presence of foreign bodies in the suction line | remove foreign bodies from the suction line |
| | malfunction of adjustment device (HPA) | contact Bondioli & Pavesi |
| | if the problem persists | contact Bondioli & Pavesi |
| Temperature too high | oil level in reservoir too low | top off oil level |
| | heat exchanger clogged or faulty | clean or repair heat exchanger |
| | clogged or faulty filters (HPV) | replace filter cartridges |
| | high operating pressure | reduce load |
| | no heat exchanger | fit a heat exchanger in the circuit |
| | transmission sized incorrectly | review transmission sizing |
| | if the problem persists | contact Bondioli & Pavesi |

Warning! Routine maintenance work on a hydraulic system is usually carried out at regular intervals and involves:

- checking the fluid level and topping up if necessary.
- cleaning and maintenance of the radiating surfaces.
- replacing the filters.
- replacing the oil.

Special maintenance involves:

- setting and regulating the pump during the first machine start-up.
- removing and reassembling the pump and motor, or parts of them.
- checking parts of the pump.

We recommend:

- perform all the operations in a clean, dust-free environment so that foreign particles are not introduced into the components.
- plug all the pressure ports with plastic caps as soon as the hydraulic pipes/hoses have been disconnected.
- replace the seals each time the components are opened.

We recommend procuring seal kits before working on the components.

Routine maintenance The recommended maintenance intervals are:

Before every machine start-up:

- check the oil level in the reservoir
- clean the heat exchanger.
- check that the reservoir breather is clean.

If used correctly, the axial piston unit requires very little maintenance. The quality of the hydraulic fluid used is a decisive factor in the life of the axial piston unit, and as such, this should be replaced at least once a year, or after 2000 hours of operation. Alternatively, it is possible to have the fluid analysed by the manufacturer thereof, to ensure that it is still suitable for use. The lifespan of the bearings is another critical factor affecting the service life of the axial piston unit. Depending on the load cycle, information regarding the lifespan of the bearings may be requested from the Bondioli & Pavesi technical assistance service.

Special maintenance There are no recommended maintenance intervals since this maintenance operation is usually necessary as the result component malfunctions.

The operations for checking the components are described in the following paragraphs, from page 12 onwards.

Efficiency checks In the event of poor hydrostatic transmission efficiency, it may be necessary to check the efficiency of the hydraulic components to establish whether it is the pump or the hydraulic motor that needs to be repaired or overhauled. In this way, you can concentrate on the component that requires maintenance without, eliminating superfluous checks that could jeopardise the correct operation of the entire hydraulic system.

To check the efficiency of the pump, a pressure gauge must be installed on the output (with full scale value of 600 bar).

Warning!



In any case, pay maximum attention to the moving parts and comply with all the safety regulations and standards in force.

Perform this test as quickly as possible to avoid overheating the pump and the system.

Fit a pressure relief valve on the pump output line to protect the axial piston unit.

- block off the output port.
- wrap up the LS pressure/flow rate regulator.
- run the pump at 1500 rpm; with the oil at around 50 degrees, adjust the pressure compensator to the prescribed calibration setting. In these conditions, the pump drain port should drain a maximum of 4/5 litres per minute.
- if the outcome of this check is positive, adjust the standby pressure to the prescribed value.

Checking distributor plate

The distributor plate is made entirely from bronze; if it contains impurities, if unsuitable fluids are used, or if the operating temperatures are too high, this component can wear easily.

Scoring on the surface in the area between the two distribution slots leads to reduced pump performance.

Components with heavily scored work surfaces that can be felt with a fingernail do not guarantee the necessary seal.

Therefore, the surfaces should be lapped (a maximum of 2 times) or the part replaced if the wear is too severe.

Checking cylinder block

The same considerations made in the previous paragraph apply to the surface of the cylinder block that rotates in contact with the bronze plate.

The sliding piston housings and the piston play must also be checked.

If there is a considerable amount of play and heavy scoring, the cylinder block must be replaced, complete with the pistons.

Checking pistons and shoes

Every piston ends in a ball joint that houses the sliding shoe on the swash plate.

Solid, abrasive impurities cause scoring on the shoe and piston; if this is very severe, we recommend replacing the parts. If it is very light, try to repair the surface by polishing with lens tissue or by lapping.

A faulty hydrostatic bearing will cause the shoe and the piston to seize; a very high rotational speed, on the other hand, will cause rounding at the edges on these parts.

In both cases, and if there is too much free play between the pistons and the shoes, they will have to be replaced.

Checking shoe retainer plate

A change in the original colour of the shoe retainer plate indicates that the unit has been operated at extremely high temperatures, which may deform the disc and increase the wear on the entire rotating unit and the swash plate.

The disc must be replaced when annular scoring, caused by impurities or wear, and which can be felt with a fingernail, appears in the area where it comes into contact with the shoes and the area that rests on the air chamber.

Checking half ball

It must be replaced if the scoring, which is usually caused by impurities in the oil, can be felt with a fingernail and if there is considerable wear, a visible sign of faulty lubrication.

- Checking swash plate** It must be replaced if there are signs of wear, such as scoring that can be felt with a fingernail, seizure caused by impurities in the oil, overheating or a faulty hydrostatic bearing on the pistons.
Also, check that the sliding area on the roller bearings or plain bearings is not damaged; if scoring can be seen, the component must be replaced.
- Checking distributor bushing** Check the bushing in the distributor where the pump shaft rotates for signs of wear in the anti-friction material, seizure or excessive play with the shaft. If necessary, replace the part.
- Checking shaft and bearing** Check the part of the shaft that rotates inside the distributor bushing for signs of wear or seizure.
check that the part of the round or grooved shaft that drives the pump does not show signs of abnormal wear.
check the bearing rollers and races: there must not be any play or signs of wear or seizure.
If there is, replace the shaft and the bearing.
- Checking servo-control** Check that the piston does not have scoring which can be felt with a fingernail and check that the sealed areas of the servo-control body in the pump are not damaged.
Check that play between the piston and its seat is kept to a minimum, while still allowing the piston to move freely without sticking.
- Labelling** An identification plate is attached to all the Bondioli & Pavesi components that leave the factory, both new and overhauled, which lists in full the product type and code, the job number and a progressive number.
If a request for spare parts is made, it is very important that all the information on this identification plate is provided.
If a product is overhauled, the plate is replaced with updated information; every modification to the pump that involves the issue of a new code must be indelibly marked on the plate.
- Protection of oil ports** All Bondioli & Pavesi components are shipped with the oil ports protected with plugs.
Metal plugs are used for unused ports and plastic ones for all the others.
The plugs should be left in position until the components are installed in the system to prevent the entry of humidity and pollutants that may damage them.
If a component has to be dismantled for repair and/or overhauling, **we recommend closing the oil ports with plugs to protect them from pollution and dirt.**
- Protection of components** Bondioli & Pavesi components are usually shipped in plastic bags to protect them from humidity and oxidation.
This packaging protects the component for a normal shipping and storage period not exceeding 20 days.
For longer periods of storage, we recommend unpacking the component and applying protective oil to the external surfaces to prevent oxidation.
Store the component in an enclosed area with low humidity.

Painting If Bondioli & Pavesi components require painting, it is very important to protect the mating surfaces, i.e.:

- flanges
- fittings
- connection ports
- identification plate

* Protect from paint

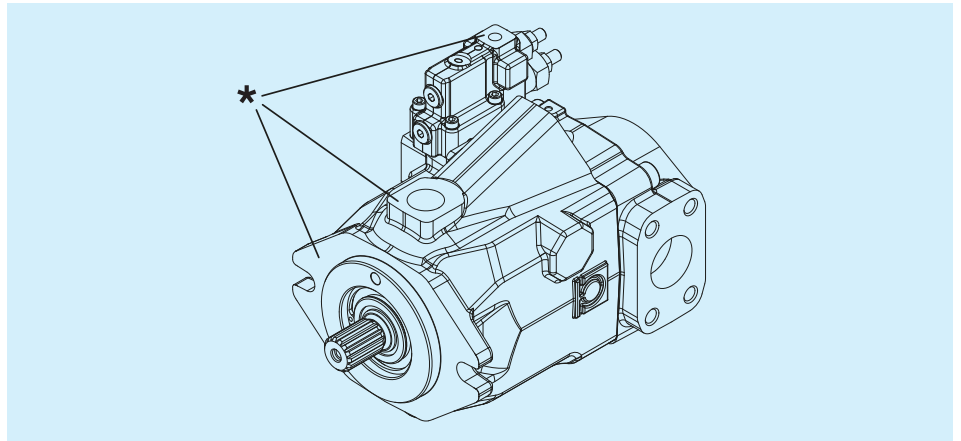

* Protect from paint

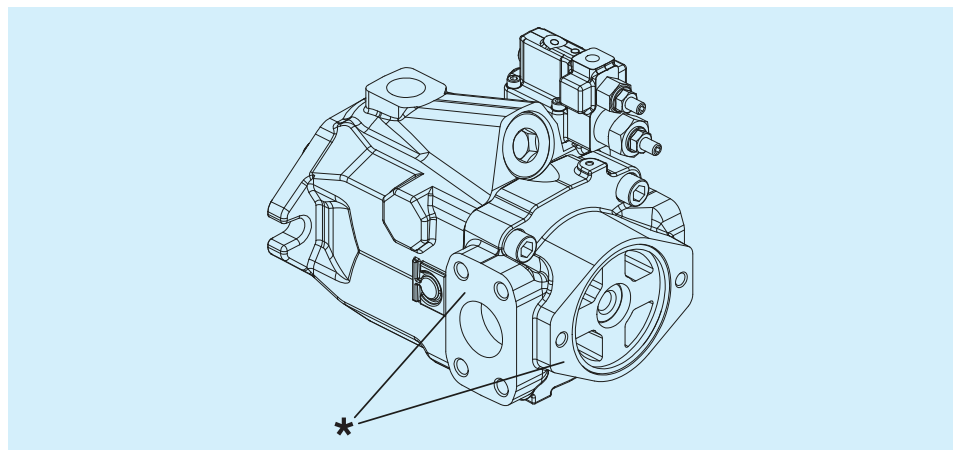

The following components, if present, should also be protected:

- solenoid valves
- operating levers
- filter cartridges
- electronic connections
- ECUs
- pressure, speed, angle sensors

Warning!:

If electrostatically painted, the electrical/electronic components on the Bondioli & Pavesi pumps and motors, for example pressure, speed and angle sensors, must be protected as follows:

- Each sensor must be connected to the product case by a dedicated cable. Use the thread on top of the shaft or the servo-control for the earth connection, inserting flat washers to protect the cable lug.

* Protect from paint

