



Introduction	3
SMAT55	5
SMAT69	8
SMAT70	11
SMAT77	14
SMAT-FAN	17
SMAT POWER FAN	20
IO EXPANDER	23
SSPRO	26
Connectors and Wiring	29

Introduction The electronic control units (ECU) allow to monitor and manage different types of applications in the hydraulic field.

Thanks to specific algorithms, Bondioli & Pavesi ECUs acquire information on the state of the system and carry out corrective measures and actions necessary to guarantee certain functions. These can be related to safety requirements, generic control strategies or specific customer requirements.

The management of inputs and outputs can be implemented in various systems of pre-existing interconnected components.

Diagnostic functions are available on all models such as the detection of electrical disconnections, short circuits, open circuits, but also the monitoring of outputs and the signalling of alarms.

The outputs, with double activation consent, return current feedback and are available in version on/off or PWM.

The ECUTuner application software is also available for configuring the parameters during calibration and checking the diagnoses on the system. The interface is intuitive and can be set at different access levels.

HPEE55 Series

Standard applications



Prior to use, carefully read the GENERAL INSTRUCTIONS FOR USE OF ELECTRONIC CONTROL UNITS

Dimensions

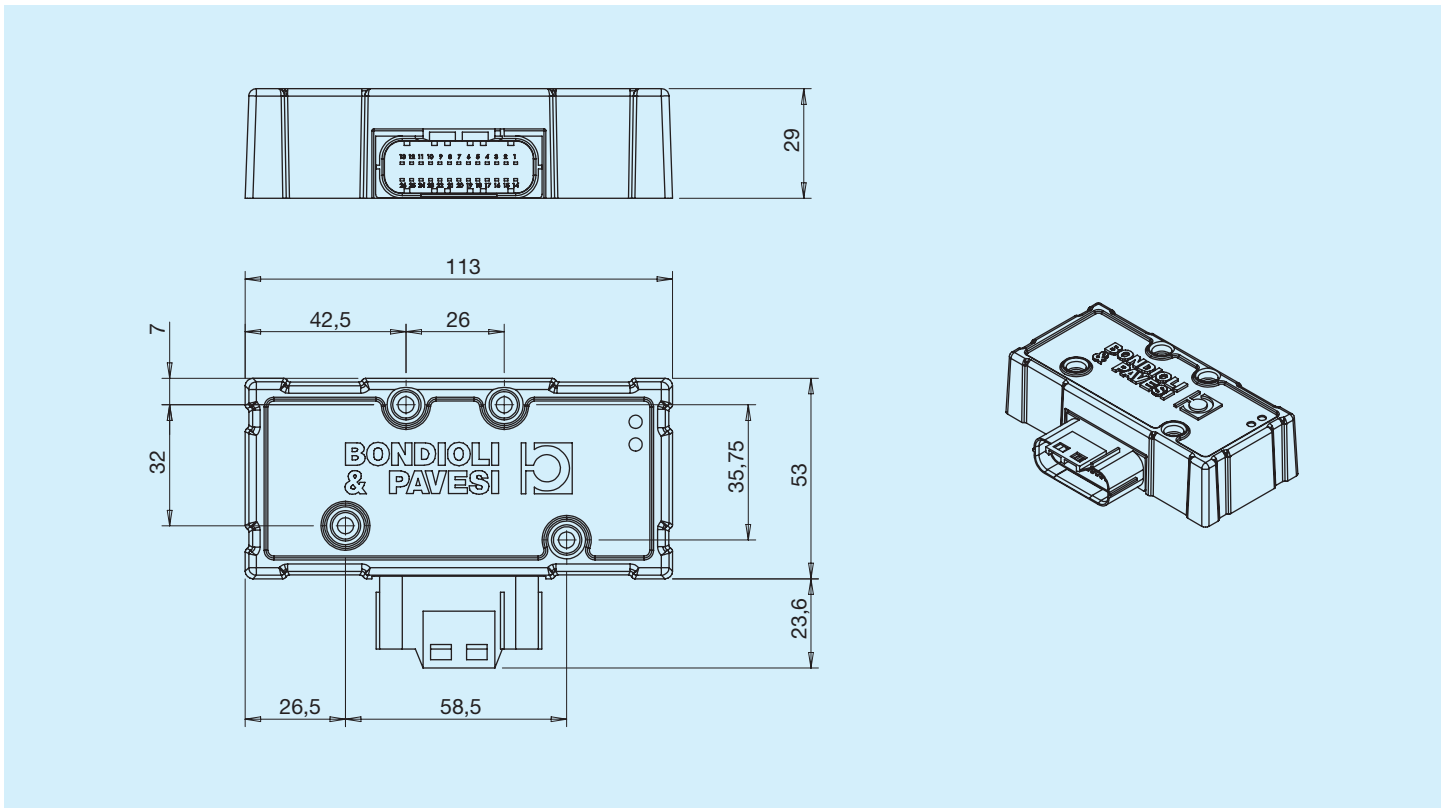

Electrical and electronic characteristics

Power supply		9 - 32 Vdc
Current consumption	Standby	80 mA
	Maximum current on one channel	3 A @ 12 Vdc 2 A @ 24 Vdc
	Maximum total current	4 A @ 12 Vdc 3 A @ 24 Vdc
Sensor power supply +5V		2; (5 ± 0.25) V; 100 mA
Main microcontroller		8 bit – 32 MHz
Electromagnetic Compatibility (EMC)	According to the standards:	
		ISO 13766
		ISO 7637
		ISO 11452 ISO 14982
CAN BUS connection		1 CAN 2.0B, ISO11898
RS232 connection		1
Connector		JAE 26-way - counterpart HPECNS00700

Input

Type	N°	Activation	Frequency	Type	N°	Range
Digital	4	VBatt+	-	Analogue	2	0-5Vdc 0-10Vdc 0-20mA
Frequency	2	GND	10kHz max			

Output

Type	N°
Digital / PWM	4 (2 combinable current feedbacks)
PWM output frequency	100 - 400 Hz

Mechanical and environmental characteristics

Operating temperature	(-25 ... 85) °C (-13 / 185 °F)
Storage temperature	(-40 ... 85) °C (-40 / 185 °F)
Protection index*	IP67
Resistance to vibration	UNI EN 60068-2-6
Shock resistance	ISO 15003, section 5.5.2 level 3

* With correctly fixed connector
The unused pins must be suitably plugged.

HPEE69 Series
Standard applications



 Prior to use, carefully read the GENERAL INSTRUCTIONS FOR USE OF ELECTRONIC CONTROL UNITS

Dimensions

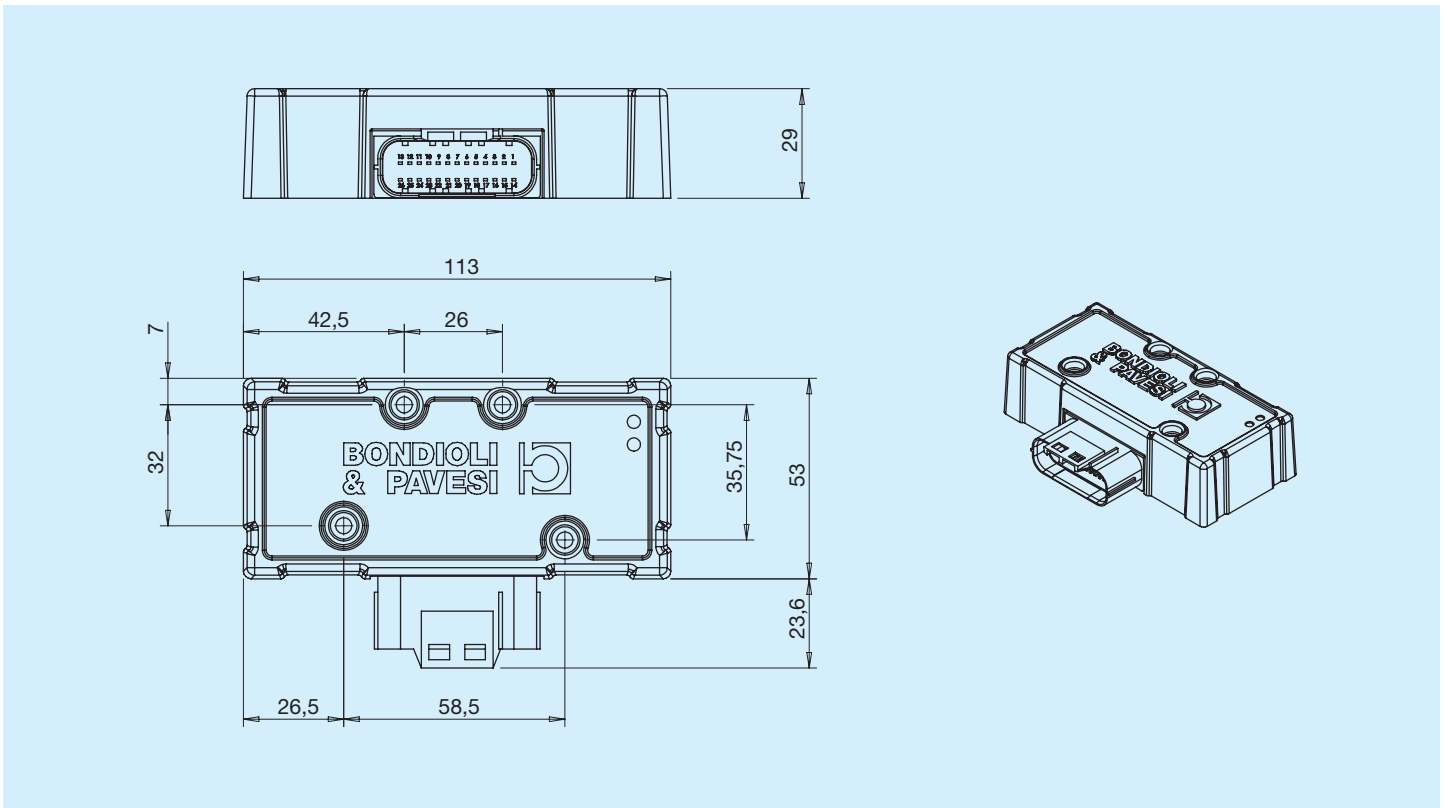

Electrical and electronic characteristics

Rated voltage	9 - 32 Vdc	
Current consumption	Standby	80mA
	Maximum current on one channel	3A @ 12Vdc 2A @ 24Vdc
	Maximum total current	4A @ 12Vdc 3A @ 24Vdc
Sensor power supply +5 V	2; (5 +/- 0.25) V; 100mA	
Main microcontroller	8bit - 32MHz	
CAN BUS connection	1 CAN 2.0 B, ISO11898	
RS232 connection	1	
Electromagnetic compatibility	According to the standards:	
	ISO13766	
	ISO7637	
	ISO11452 ISO14982	
Connector	JAE 26-way - counterpart HPECNS00700	

Input

Type	N°	Activation	Frequency	Type	N°	Range
Digital	4	VBatt+	-	Analogue	2	0-5Vdc 0-10Vdc 0-20mA
Frequency	2	GND	10kHz			

Output

Type	N°
PWM digital outputs	4 (2 combinable current feedbacks)
PWM output frequency	100 - 400 Hz

Mechanical and environmental characteristics

Operating temperature	(-25 ... 85) °C (-13 / 185 °F)
Storage temperature	(-40 ... 85) °C (-40 / 185 °F)
Protection index*	IP67
Conforms to vibrations UNI EN 60068-2-6	Yes
Conforms to mechanical shocks ISO 15003, par. 5.5.2 level 3	Yes

* With correctly fixed connector
The unused pins must be suitably plugged.

HPEESF Series

For brushless electric fans



Prior to use, carefully read the GENERAL INSTRUCTIONS FOR USE OF ELECTRONIC CONTROL UNITS

Dimensions

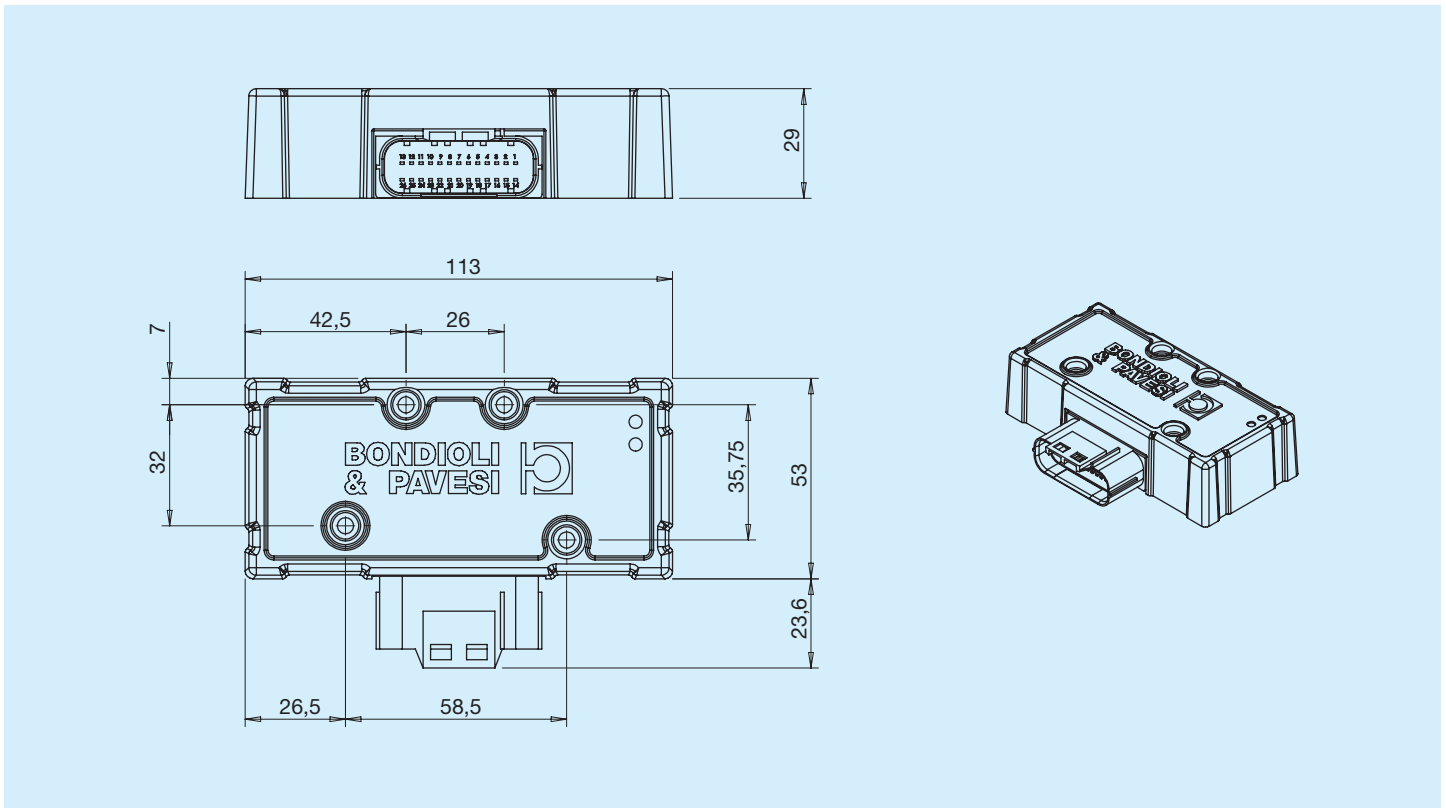

Electrical and electronic characteristics

Rated voltage	9 - 32 Vdc	
Current consumption	Standby	40mA
	Maximum current PWM low side driver	100mA @ 12 Vdc 100mA @ 24Vdc
	Maximum total current	450mA @ 12Vdc 450mA @ 24Vdc
Sensor power supply +5 V	no	
Main microcontroller	8bit - 32MHz	
CAN BUS connection	1 CAN 2.0 B, ISO11898	
RS232 connection	1	
Electromagnetic compatibility	According to the standards:	
	ISO13766	
	ISO7637	
	ISO11452 ISO14982	
Connectors	JAE 26-way - counterpart HPECNS00700	

Input

Type	N°	Activation	Frequency	Type	N°	Range
Digital	3	VBatt+	-	Analogue	4	0-5Vdc 0-20mA RHEO
Frequency	2	GND	10kHz			

Output

Type	N°
Low side driver PWM digital outputs	4
PWM output frequency	100 - 400Hz

Mechanical and environmental characteristics

Operating temperature	(-25 ... 85) °C (-13 / 185 °F)
Storage temperature	(-40 ... 85) °C (-40 / 185 °F)
Protection index*	IP67
Conforms to vibrations UNI EN 60068-2-6	Yes
Conforms to mechanical shocks ISO 15003, par. 5.5.2 level 3	Yes

* With correctly fixed connector
The unused pins must be suitably plugged.

HPEESH Series

For hydraulic systems with on-off and proportional valves



 Prior to use, carefully read the GENERAL INSTRUCTIONS FOR USE OF ELECTRONIC CONTROL UNITS

Dimensions

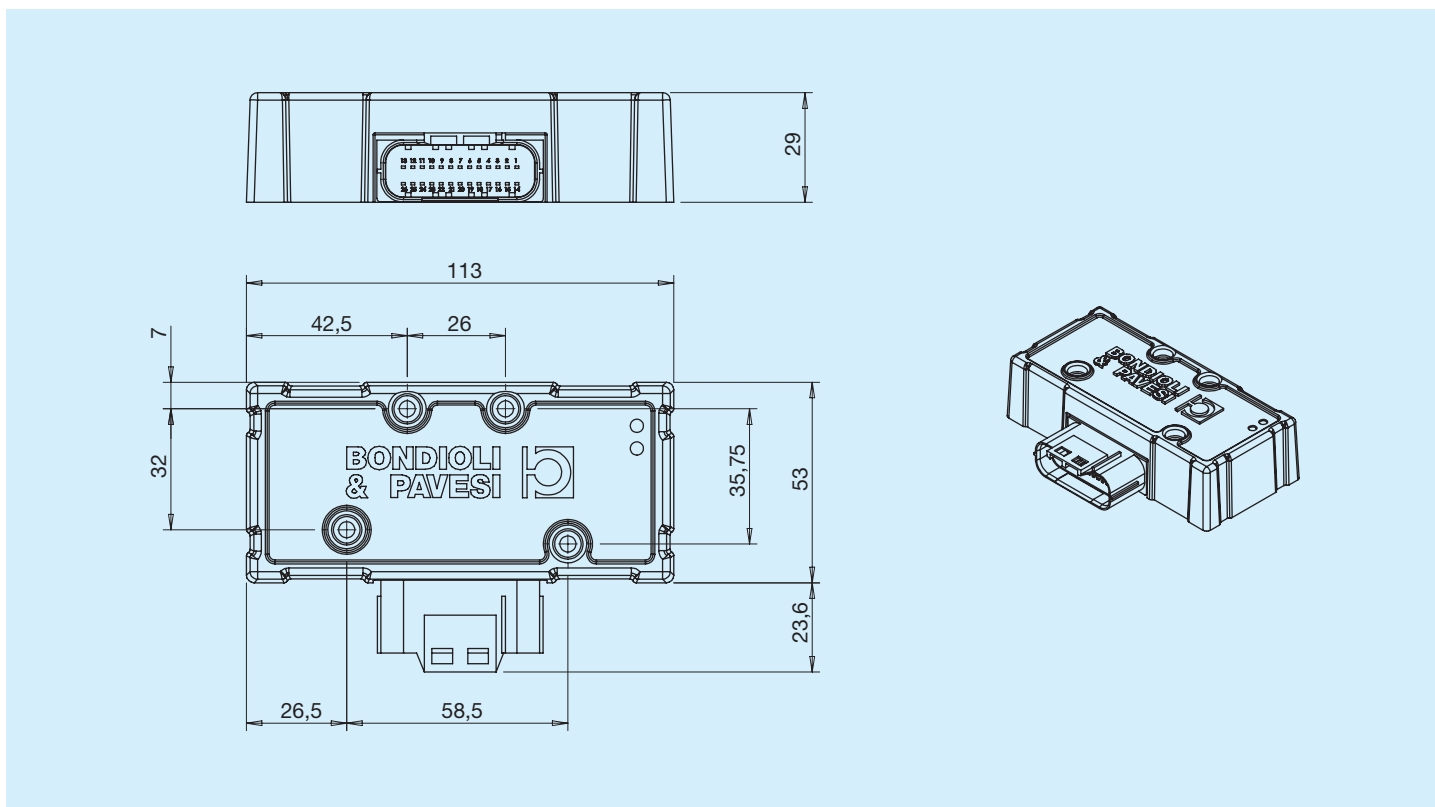

Electrical and electronic characteristics

Rated voltage		9 - 32 Vdc
Current consumption	Standby	40mA
	Maximum current PWM low side driver	100mA @ 12Vdc 100mA @ 24Vdc
	Maximum current PWM high side driver	3A @ 12Vdc 2A @ 24Vdc
	Maximum total current	4A @ 12Vdc 3A @ 24Vdc
Sensor power supply +5 V		no
Main microcontroller		8bit – 32MHz
CAN BUS connection		1 CAN 2.0 B, ISO11898
RS232 connection		1
Electromagnetic compatibility	According to the standards:	
		ISO 13766
		ISO7637
		ISO11452 ISO14982
Connectors		JAE 26-way - counterpart HPECNS00700

Input

Type	N°	Activation	Frequency	Type	N°	Range
Digital	1	VBatt+	-	Analogue	4	0-5Vdc RHEO
Frequential	2	GND	10kHz			
Analogue	4	0-5Vdc	RHEO			

Output

Type	N°
PWM digital outputs high side driver high power	2 (current feedback)
PWM digital outputs low side driver low power	2
PWM output frequency	100 - 400Hz

Mechanical and environmental characteristics

Operating temperature	(-25 ... 85) °C (-13 / 185 °F)
Storage temperature	(-40 ... 85) °C (-40 / 185 °F)
Protection index*	IP67
Conforms to vibrations UNI EN 60068-2-6	Yes
Conforms to mechanical shocks ISO 15003, par. 5.5.2 level 3	Yes

* With correctly fixed connector
The unused pins must be suitably plugged.

HPEEO6D00000001001

Discrete logic output expansion



Prior to use, carefully read the GENERAL INSTRUCTIONS FOR USE OF ELECTRONIC CONTROL UNITS

Dimensions

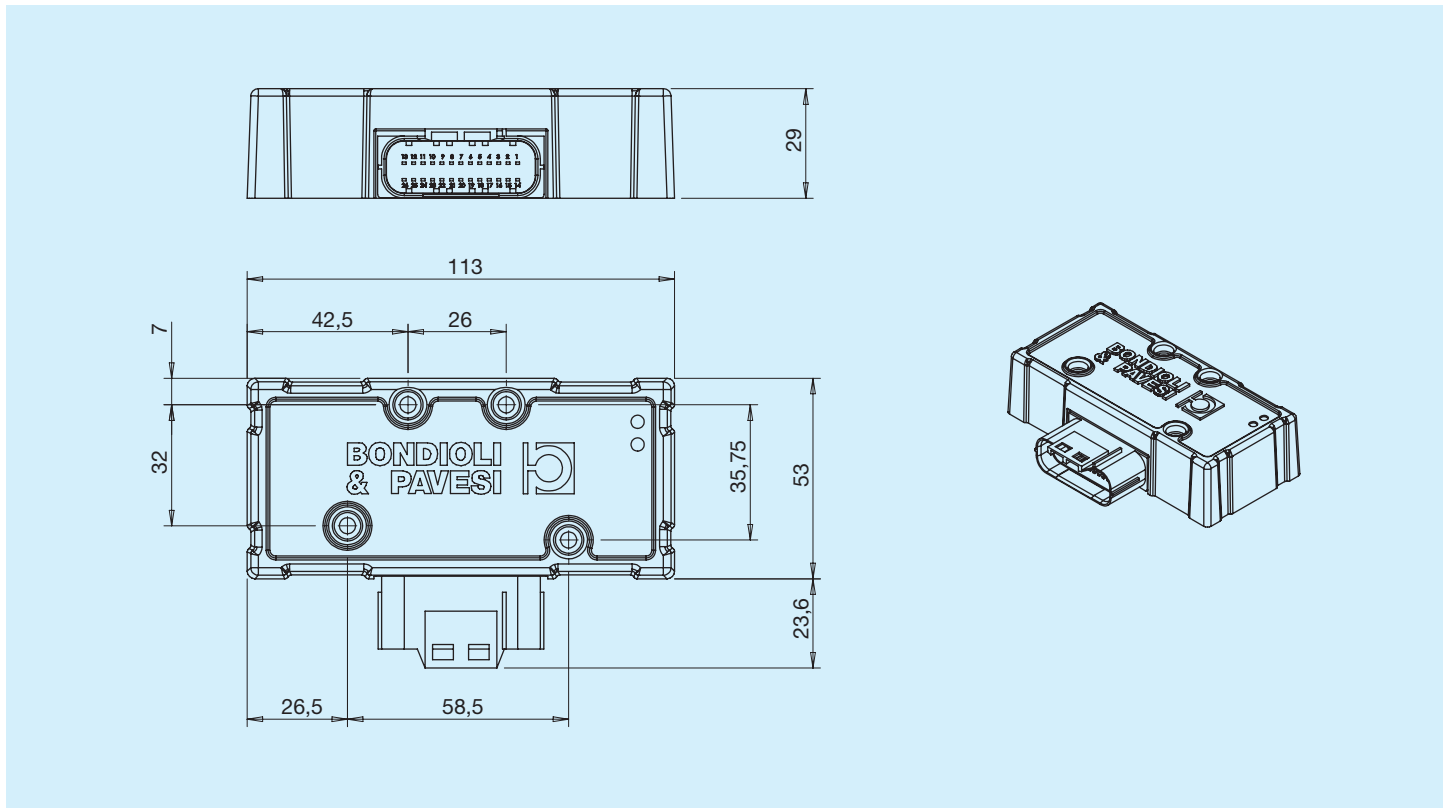

Electrical and electronic characteristics

Rated voltage	9 - 32 Vdc	
Current consumption	Standby	80mA
	Maximum current on one channel	3A @ 12Vdc 2A @ 24Vdc
	Maximum total current	9A @ 12Vdc 6A @ 24Vdc
	Minimum load current	0.02 A
Sensor power supply +5 V	no	
Main microcontroller	none	
CAN BUS connection	no	
RS232 connection	no	
Electromagnetic compatibility	According to the standards:	
	ISO13766	
	ISO7637	
	ISO11452 ISO14982	
Connector	JAE 26-way - counterpart HPECNS00700	

Input

Type	N°	Activation	Frequency
Digital	6	VBatt+	-

Output

Type	N°
Digital outputs	6

Mechanical and environmental characteristics

Operating temperature	(-25 ... 85) °C (-13 / 185 °F)
Storage temperature	(-40 ... 85) °C (-40 / 185 °F)
Protection index*	IP67
Conforms to vibrations UNI EN 60068-2-6	Yes
Conforms to mechanical shocks ISO 15003, par. 5.5.2 level 3	Yes

* With correctly fixed connector
The unused pins must be suitably plugged.

General purpose for safety relevant applications



 Prior to use, carefully read the GENERAL INSTRUCTIONS FOR USE OF ELECTRONIC CONTROL UNITS

Dimensions

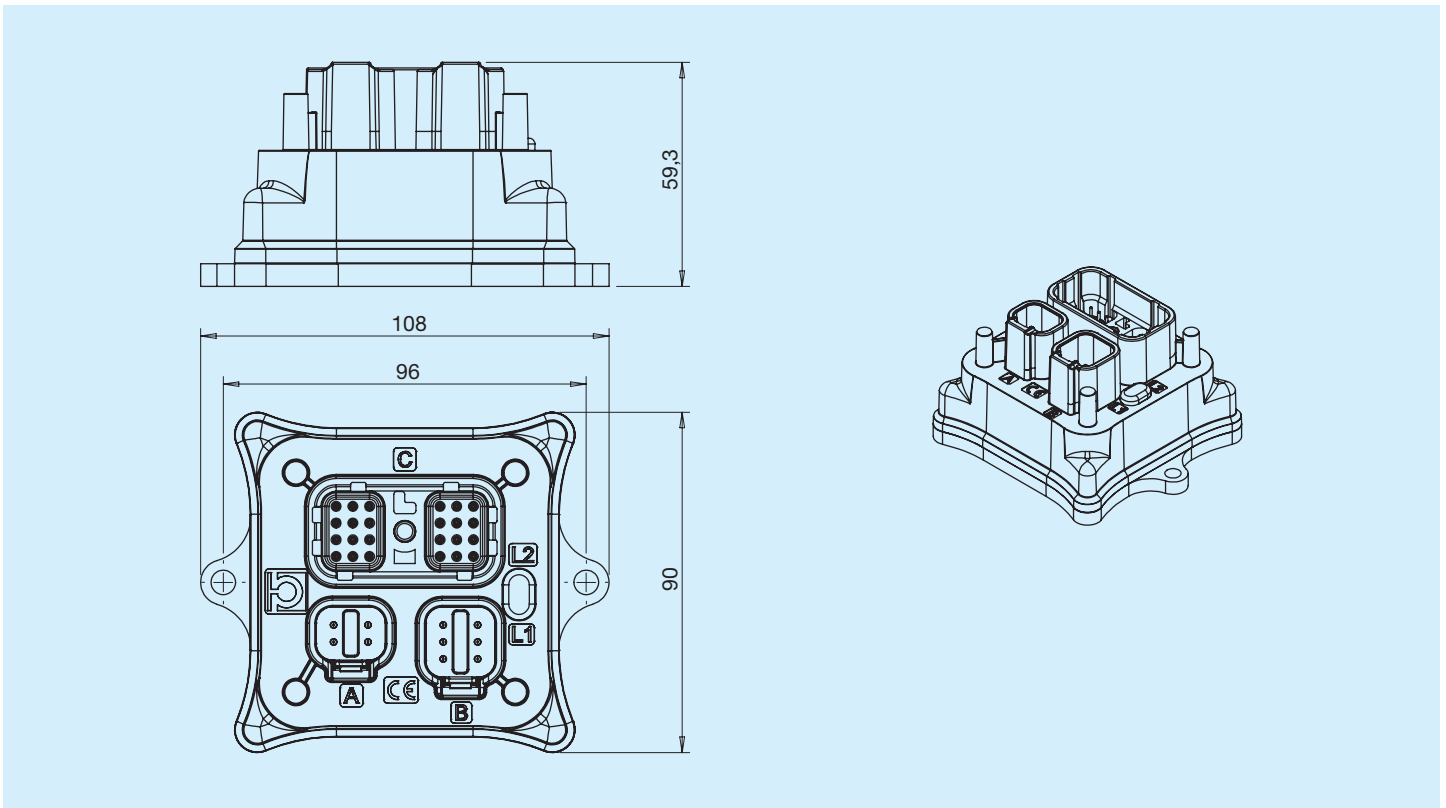

Electrical and electronic characteristics

Rated voltage		8-32Vdc
Current consumption	Standby	40mA @ 12Vdc 25mA @ 24Vdc
	Maximum current on one channel	3A @ 12Vdc 3A @ 24Vdc
	Maximum total current	9A @ 12Vdc 9A @ 24Vdc
Sensor power supply +5 V		1; (5 +/- 0.125) V; 300mA
Main microcontroller		ARM Cortex; 32bit - 72MHz
CAN BUS connection		2 CAN 2.0 B, ISO11898
RS232 connection		No
Electromagnetic compatibility	According to the standards:	
		ISO13766
		ISO7637
		ISO11452 ISO14982
Connectors		DT6-4S, DT06-6S, DRC26-24SA - counterpart HPEAKITCONNSSPSP

Input

Type	N°	Voltage	Frequency	Type	N°	Range
Digital / Frequential	6	VBatt+	0-10kHz	Analogue	6	0-5Vdc 0-10Vdc 4-20mA RHEO
Analogue	6	0-5Vdc 0-10Vdc 4-20mA	RHEO			

Output

Type	N°
PWM digital outputs	8
PWM output frequency	100Hz - 1kHz

Mechanical and environmental characteristics

Operating temperature	(-25 ... 85) °C (-13 / 185 °F)
Storage temperature	(-40 ... 85) °C (-40 / 185 °F)
Protection index*	IP67
Conforms to vibrations UNI EN 60068-2-6	Yes
Conforms to mechanical shocks ISO 15003, par. 5.5.2 level 3	Yes

* With correctly fixed connector
The unused pins must be suitably plugged.

HPEE70 Series

Standard applications with multiple frequency inputs



Prior to use, carefully read the GENERAL INSTRUCTIONS FOR USE OF ELECTRONIC CONTROL UNITS

Dimensions

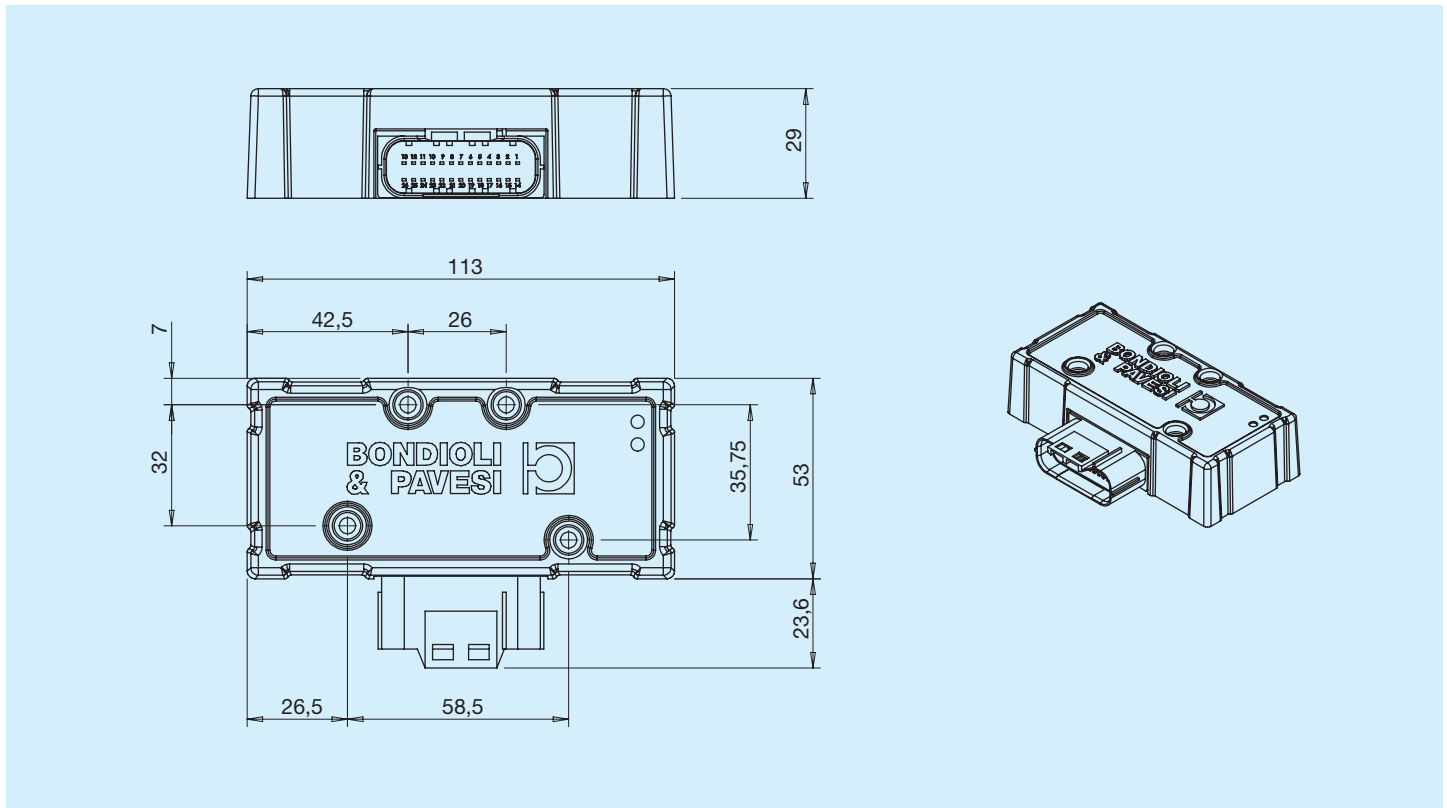

Electrical and electronic characteristics

Rated voltage	9 - 32 Vdc	
Current consumption	Standby	80mA
	Maximum current on one channel	3A @ 12Vdc 2A @ 24Vdc
	Maximum total current	4A @ 12Vdc 3A @ 24Vdc
Sensor power supply +5 V	2; (5 +/- 0.25) V; 100mA	
Main microcontroller	8bit - 32MHz	
CAN BUS connection	1 CAN 2.0 B, ISO11898	
RS232 connection	1	
Electromagnetic compatibility	According to the standards:	
	ISO13766	
	ISO7637	
	ISO11452 ISO14982	
Connector	JAE 26-way - counterpart HPECNS00700	

Input

Type	N°	Activation	Frequency	Type	N°	Range
Digital	3	VBatt+	-	Analogue	2	0-5Vdc 0-10Vdc 0-20mA
Frequential	2	GND	10kHz			
	1	GND	500Hz			

Output

Type	N°
PWM digital outputs	4
PWM output frequency	100 - 400 Hz

Mechanical and environmental characteristics

Operating temperature	(-25 ... 85) °C (-13 / 185 °F)
Storage temperature	(-40 ... 85) °C (-40 / 185 °F)
Protection index*	IP67
Conforms to vibrations UNI EN 60068-2-6	Yes
Conforms to mechanical shocks ISO 15003, par. 5.5.2 level 3	Yes

* With correctly fixed connector
The unused pins must be suitably plugged.

HPEE77 Series
Standard applications - high power outputs



 Prior to use, carefully read the GENERAL INSTRUCTIONS FOR USE OF ELECTRONIC CONTROL UNITS

Dimensions

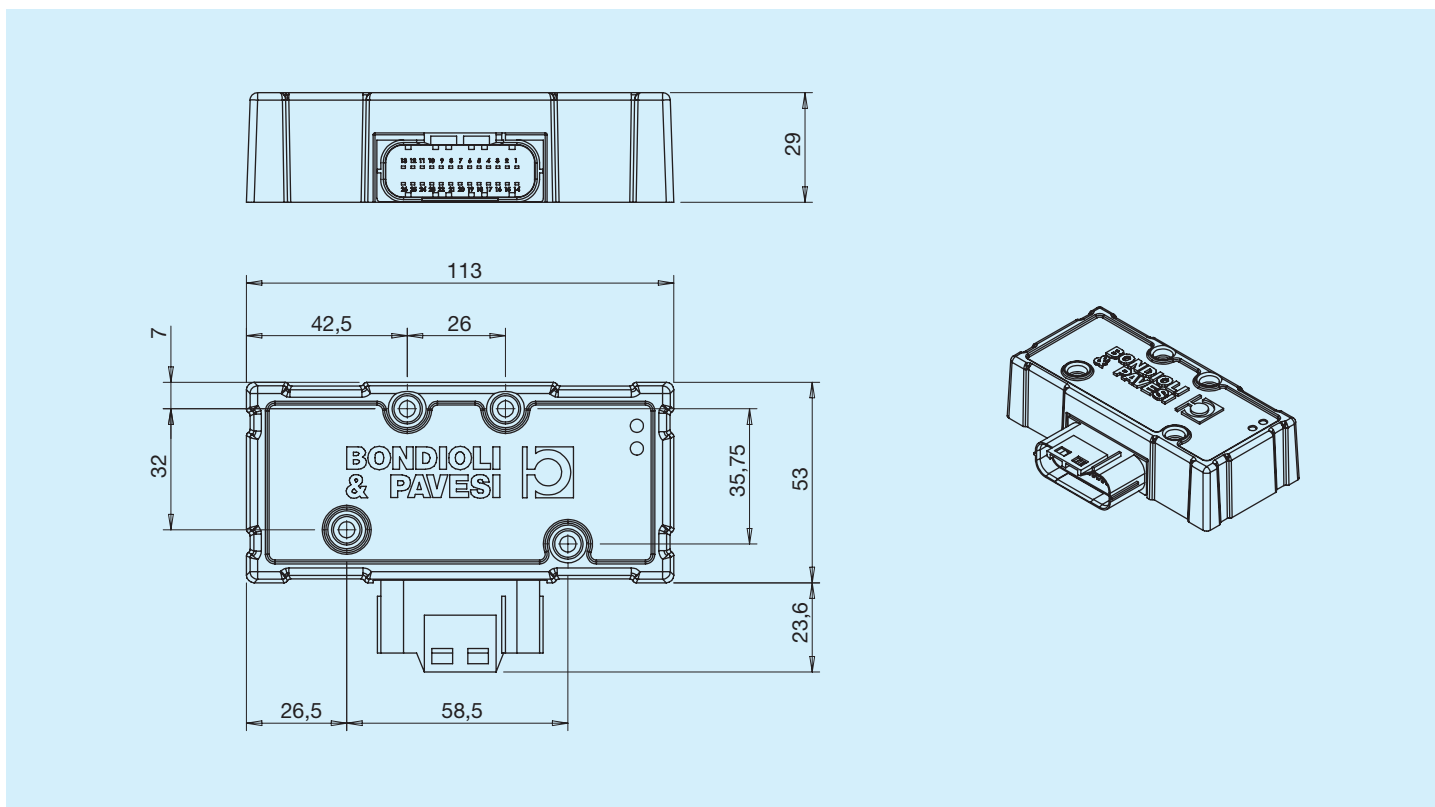

Electrical and electronic characteristics

Rated voltage	9 - 32 Vdc	
Current consumption	Standby	80mA
	Maximum current on one channel	6A @ 12Vdc 4A @ 24Vdc
	Maximum total current	6A @ 12Vdc 4A @ 24Vdc
Sensor power supply +5 V	2; (5 +/- 0.25) V; 100mA	
Main microcontroller	8bit - 32MHz	
CAN BUS connection	1 CAN 2.0 B, ISO11898	
RS232 connection	1	
Electromagnetic compatibility	According to the standards:	
	ISO13766	
	ISO7637	
	ISO11452 ISO14982	
Connector	JAE 26-way - counterpart HPECNS00700	

Input

Type	N°	Activation	Frequency	Type	N°	Range
Digital	4	VBatt+	-	Analogue	2	0-5Vdc 0-10Vdc 0-20mA
Frequential	2	GND	10kHz			

Output

Type	N°
PWM digital outputs	4
PWM output frequency	100 - 400 Hz

Mechanical and environmental characteristics

Operating temperature	(-25 ... 85) °C (-13 / 185 °F)
Storage temperature	(-40 ... 85) °C (-40 / 185 °F)
Protection index*	IP67
Conforms to vibrations UNI EN 60068-2-6	Yes
Conforms to mechanical shocks ISO 15003, par. 5.5.2 level 3	Yes

* With correctly fixed connector
The unused pins must be suitably plugged.

Connectors and Wiring



Prior to use, carefully read the GENERAL INSTRUCTIONS FOR USE OF ELECTRONIC CONTROL UNITS

JAE 26-way connector kit HPECNS00700 - For SMAT series

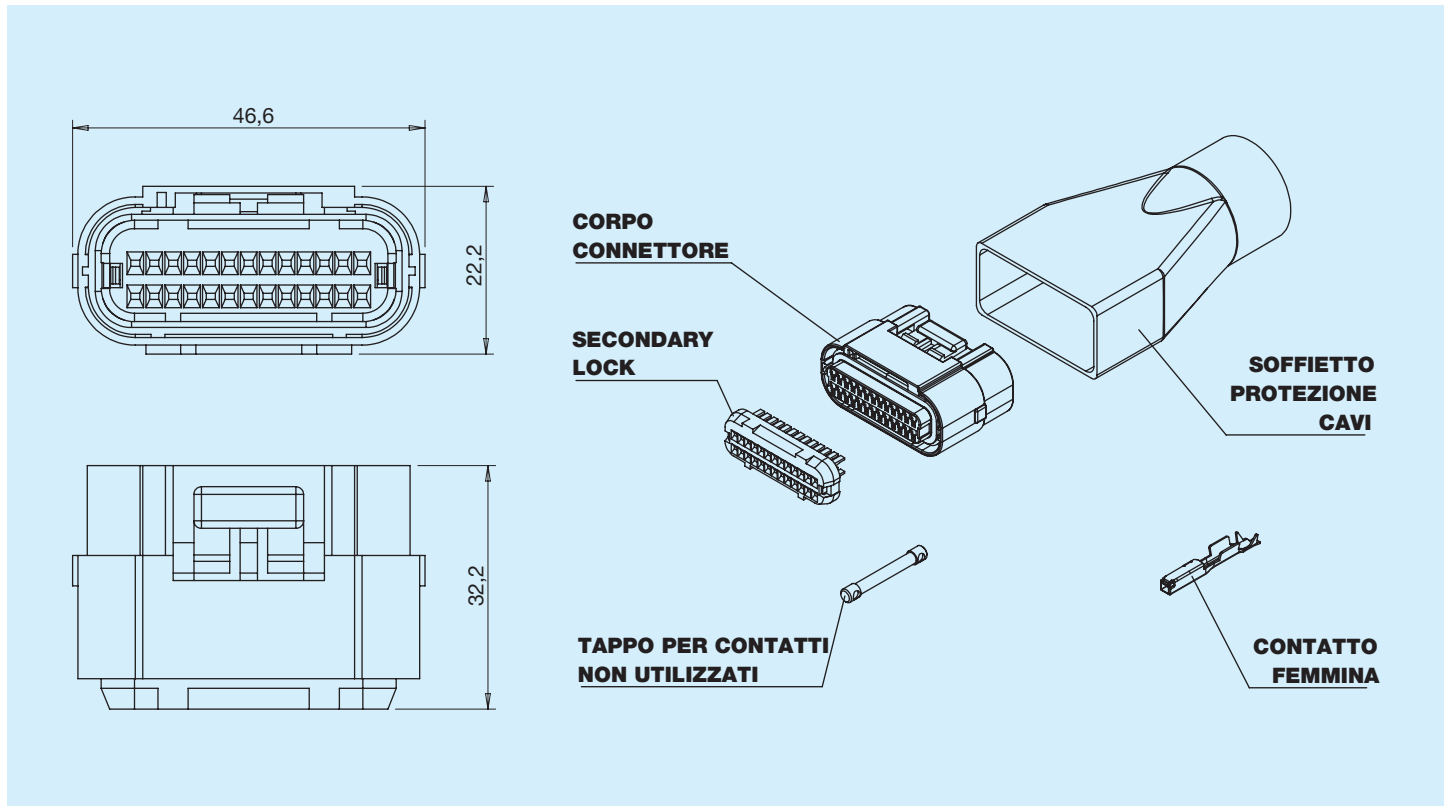

Connector kit composition

Quantity	Description
1	Connector body
1	Secondary lock
30	Female contacts
15	Plugs for unused contacts
1	Cable protection bellows

Connectors DT06-4S, DT06-6S, DRC26-

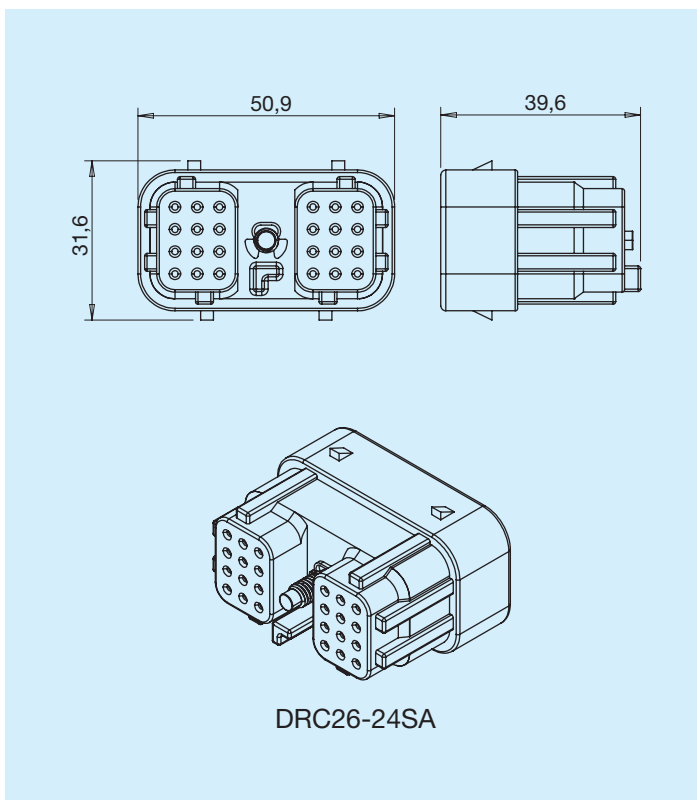
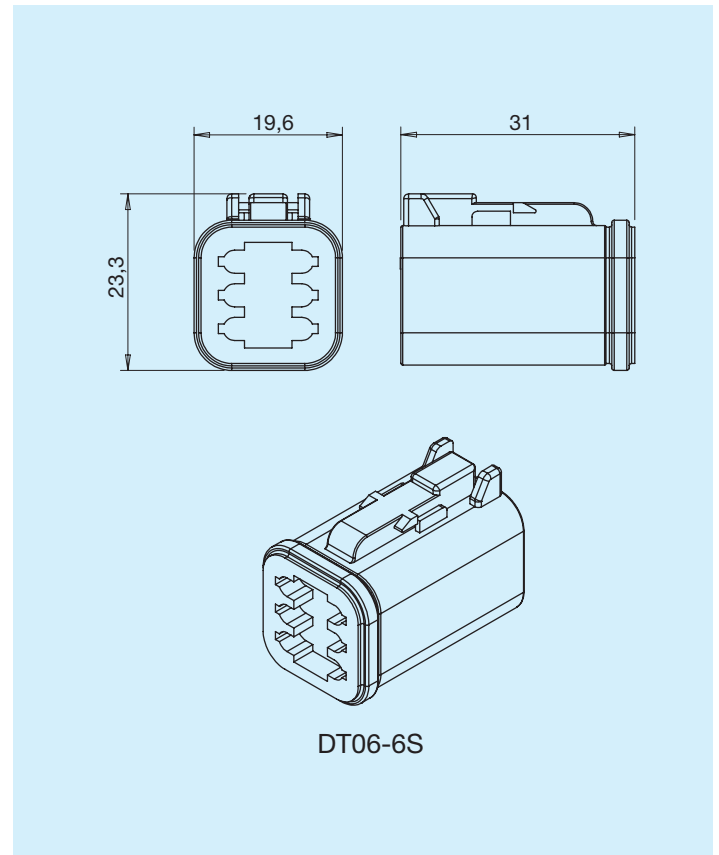
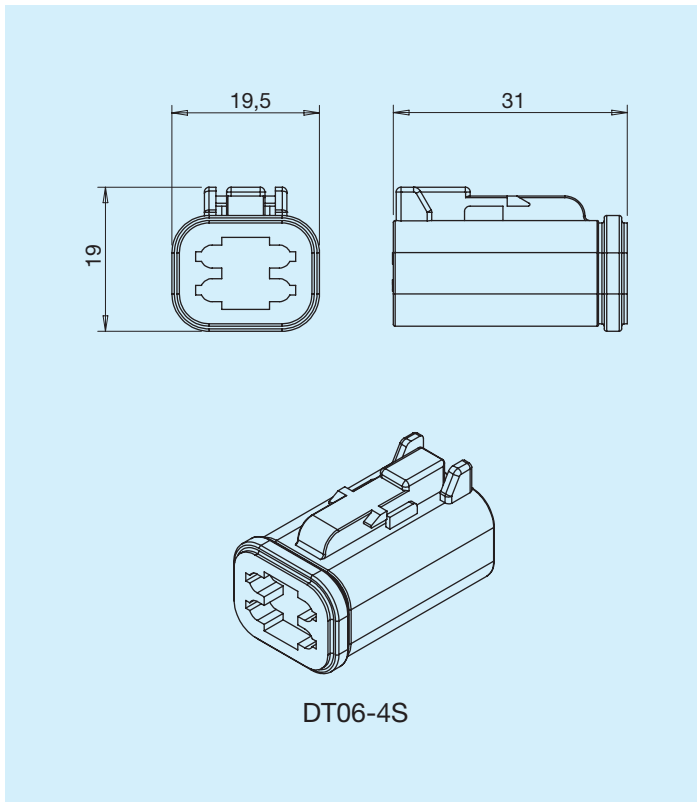

Connector kit composition

Quantity	Description
5	Deutsch type 1 blanking plugs
10	Deutsch type 2 blanking plugs
12	Deutsch type 1 female contacts
25	Deutsch type 2 female contacts
1	24-way Deutsch DRC series male connector
1	6-way Deutsch DT series male connector
1	4-way Deutsch DT series male connector
1	Deutsch cover for 24-way male connector
1	Deutsch cover for 6-way male connector
1	Deutsch cover for 4-way male connector
1	Contact block for 6-way male connector
1	Contact block for 4-way male connector
1	Extraction tool

Electrical wiring HPE5WHSMA025R - Typical use: SMAT55 - SMAT69

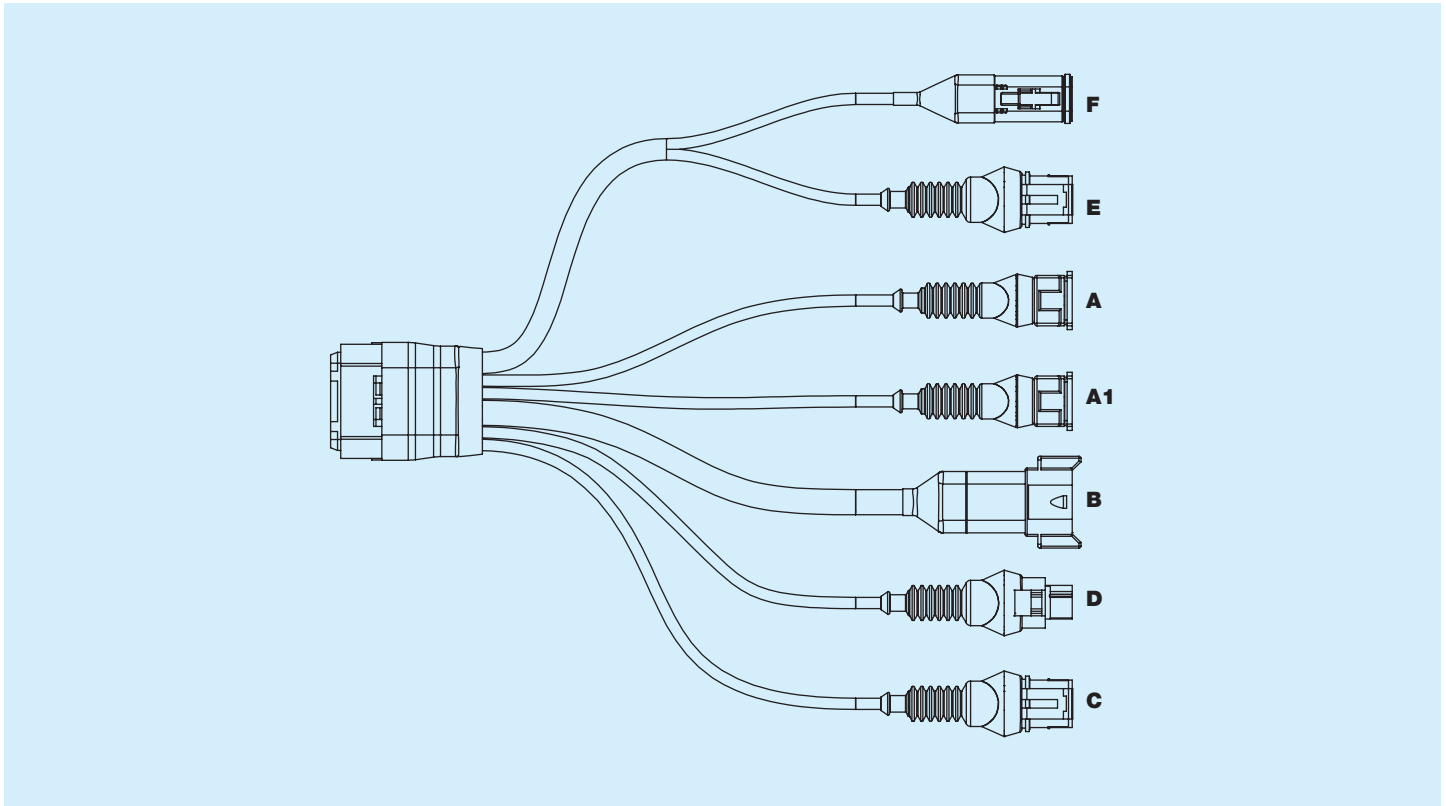

Connector	Function	Type	Length*
OUT F	Motor pressure sensor	Deutsch 4-way (DT06-4S)	1100 ± 20 cm
OUT E	Motor RPM sensor	AMP Sseal 3-way (socket)	900 ± 20 cm
OUT A	Proportional valve A	AMP JT 2-way (pin) seal version	400 ± 10 cm
OUT A1	Proportional valve B	AMP JT 2-way (pin) seal version	400 ± 10 cm
OUT B	External connection	Deutsch 8-way (DT04-08PA)	300 ± 10 cm
OUT D	Pump angle sensor	MCON 3-way (socket)	550 ± 10 cm
OUT C	Pump RPM sensor	AMP Sseal 3-way (socket)	300 ± 10 cm

* from the two ends of the connector

Electrical wiring HPE5WHSMA061R - Typical use: SMAT70

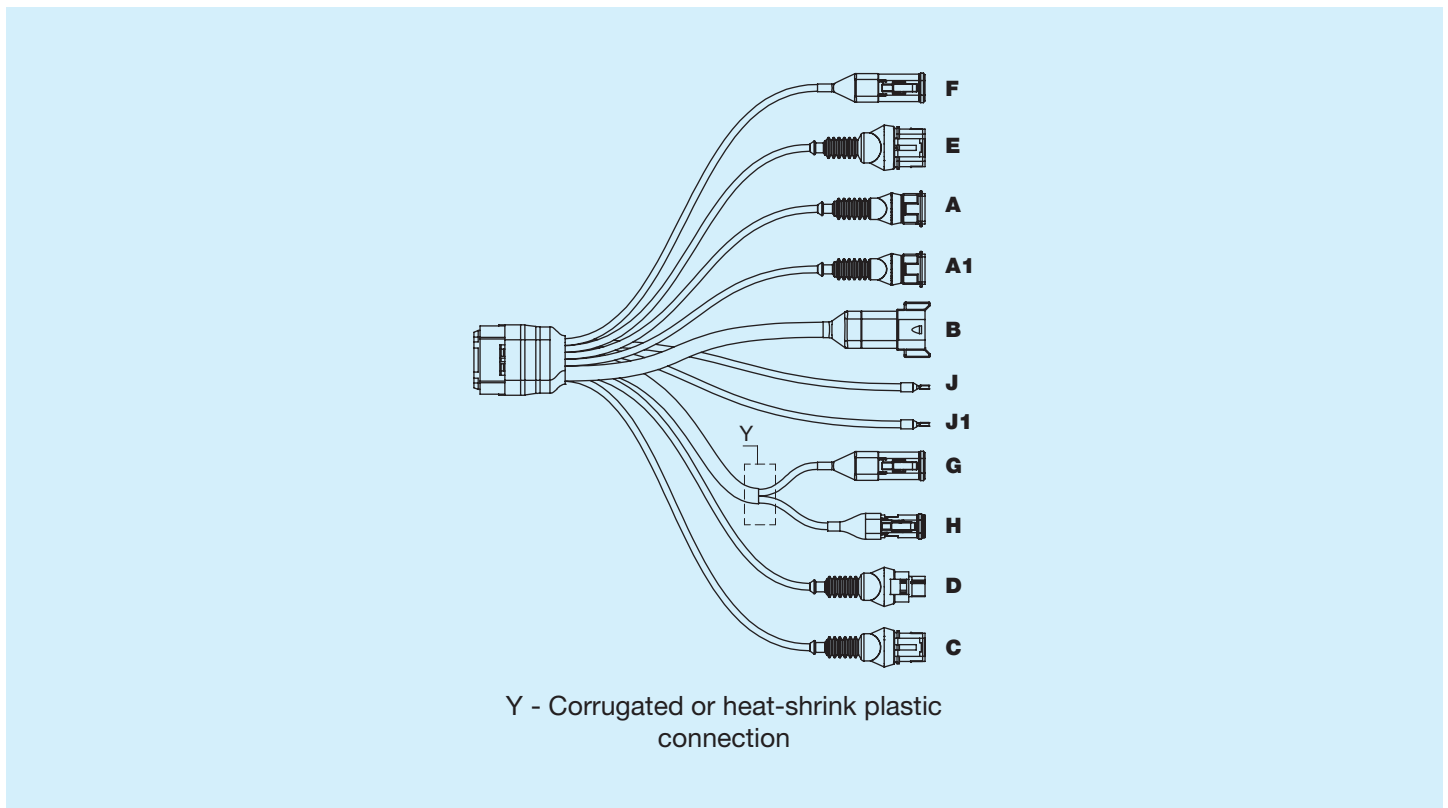

Connector	Function	Type	Length*
OUT F	Motor pressure sensor	Deutsch 4-way (DT06-4S)	1400 ± 20 cm
OUT E	Motor RPM sensor	AMP Sseal 4-way (socket)	600 ± 20 cm
OUT A	Proportional valve A	AMP JT 2-way (pin) seal version	400 ± 10 cm
OUT A1	Proportional valve B	AMP JT 2-way (pin) seal version	400 ± 10 cm
OUT B	External connection	Deutsch 8-way (DT04-08PA)	300 ± 10 cm
OUT J	GND	Atum heat-shrink	300 ± 10 cm
OUT J1	VBatt+	Atum heat-shrink	300 ± 10 cm
OUT G	Supply pressure	Deutsch 4-way (DT06-4S)	1200 ± 20 cm
OUT H	Brake valve	Deutsch 2-way (DT06-2S)	1200 ± 20 cm
OUT D	Pump angle sensor	MCON 3-way (socket)	650 ± 10 cm
OUT C	Pump RPM sensor	AMP Sseal 3-way (socket)	300 ± 10 cm

* from the two ends of the connector

Electrical wiring HPE5WHSMA045R - GENERAL PURPOSE

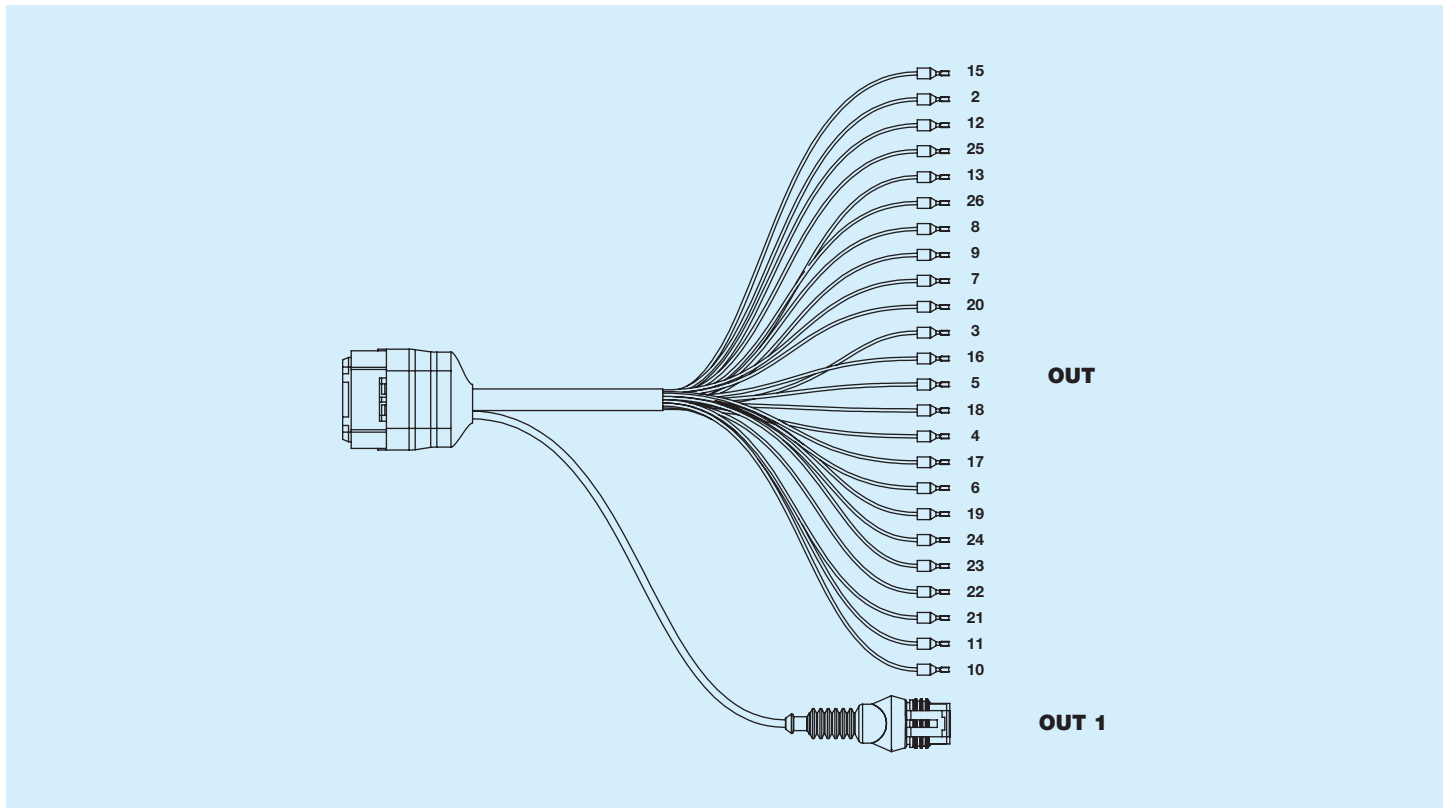

Connector	Function	Type	Length*
OUT			
Common part			100 ± 3 cm
15	CAN communication H	Free terminal	30 ± 2 cm
2	CAN communication L	Free terminal	30 ± 2 cm
12	Power supply +	Free terminal	30 ± 2 cm
25	Power supply +	Free terminal	30 ± 2 cm
13	Power supply -	Free terminal	30 ± 2 cm
26	Power supply -	Free terminal	30 ± 2 cm
8	Sensor power supply +	Free terminal	30 ± 2 cm
9	Sensor power supply +	Free terminal	30 ± 2 cm
7	Sensor power supply -	Free terminal	30 ± 2 cm
20	Sensor power supply -	Free terminal	30 ± 2 cm
3	Analogue input 0	Free terminal	30 ± 2 cm
16	Analogue input 1	Free terminal	30 ± 2 cm
5	Digital input 0	Free terminal	30 ± 2 cm
18	Digital input 1	Free terminal	30 ± 2 cm
4	Digital input 2	Free terminal	30 ± 2 cm
17	Digital input 3	Free terminal	30 ± 2 cm
6	Frequency input 0	Free terminal	30 ± 2 cm
19	Frequency input 1	Free terminal	30 ± 2 cm
24	Digital output 0	Free terminal	30 ± 2 cm
23	Digital output 1	Free terminal	30 ± 2 cm
22	Digital output 2	Free terminal	30 ± 2 cm
21	Digital output 3	Free terminal	30 ± 2 cm
11	Current feedback 0	Free terminal	30 ± 2 cm
10	Current feedback 1	Free terminal	30 ± 2 cm
OUT 1	RS 232 communication	AMP Sseal 3-way (socket)	30 ± 2 cm

* from the two ends of the connector

Electrical wiring HPE5WHSMF002R - Typical use: SMAT-FAN

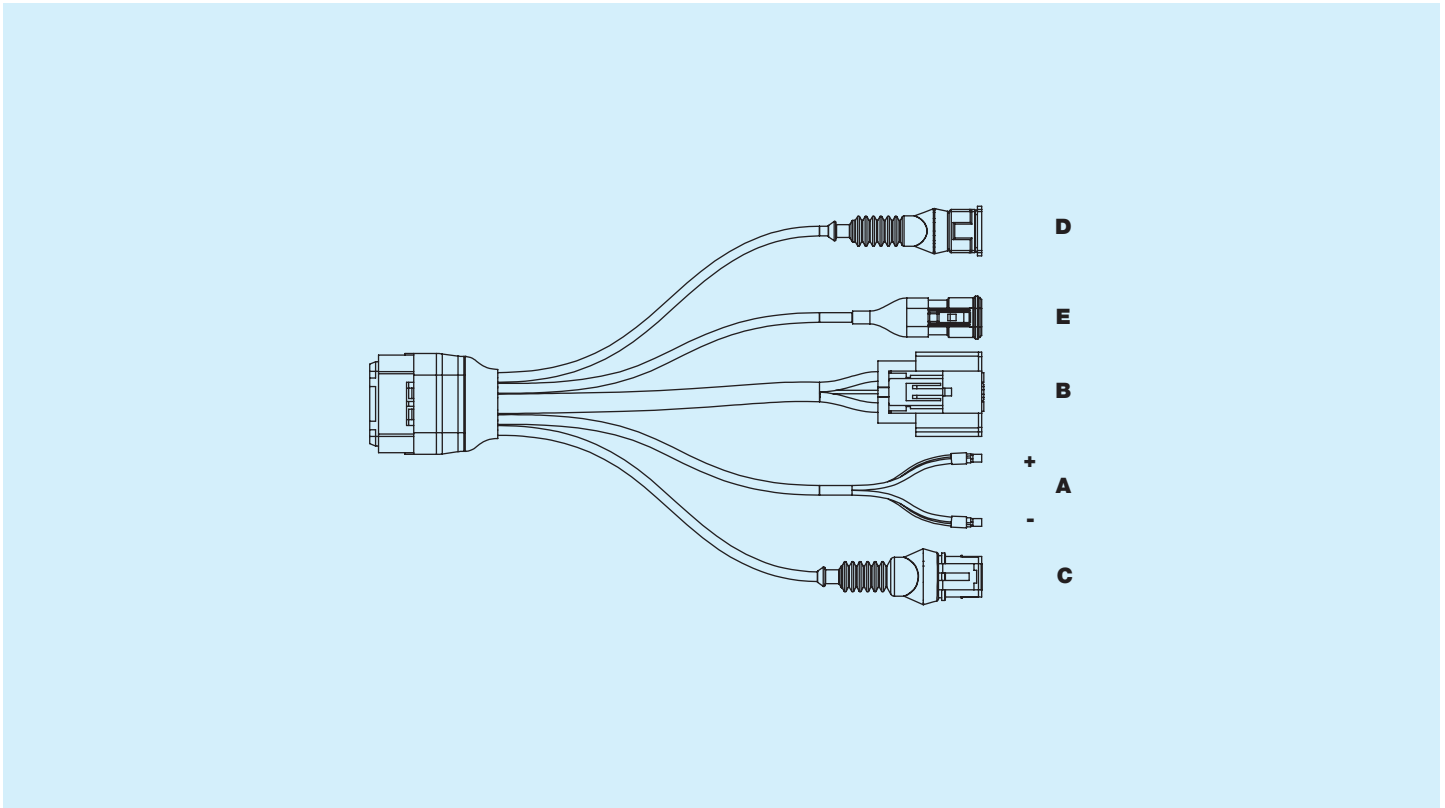

Connector	Function	Type	Length*
OUT A	Power supply	2 separate contacts for pos./neg.	100 ± 15 cm
OUT B	Brushless fan	Yazaki hybrid 4-way (pin)	100 ± 15 cm
OUT C	RS 232 communication	AMP Sseal 3-way (pin)	30 ± 15 cm
OUT D	Temperature sensor	AMP JT 2-way (pin) seal version	100 ± 15 cm
OUT E	CAN Bus communication	Deutsch 3-way (DT06-3S)	30 ± 15 cm

* from the two ends of the connector

Electrical wiring HPE5WHSPF003R - Typical use: SMAT POWER FAN

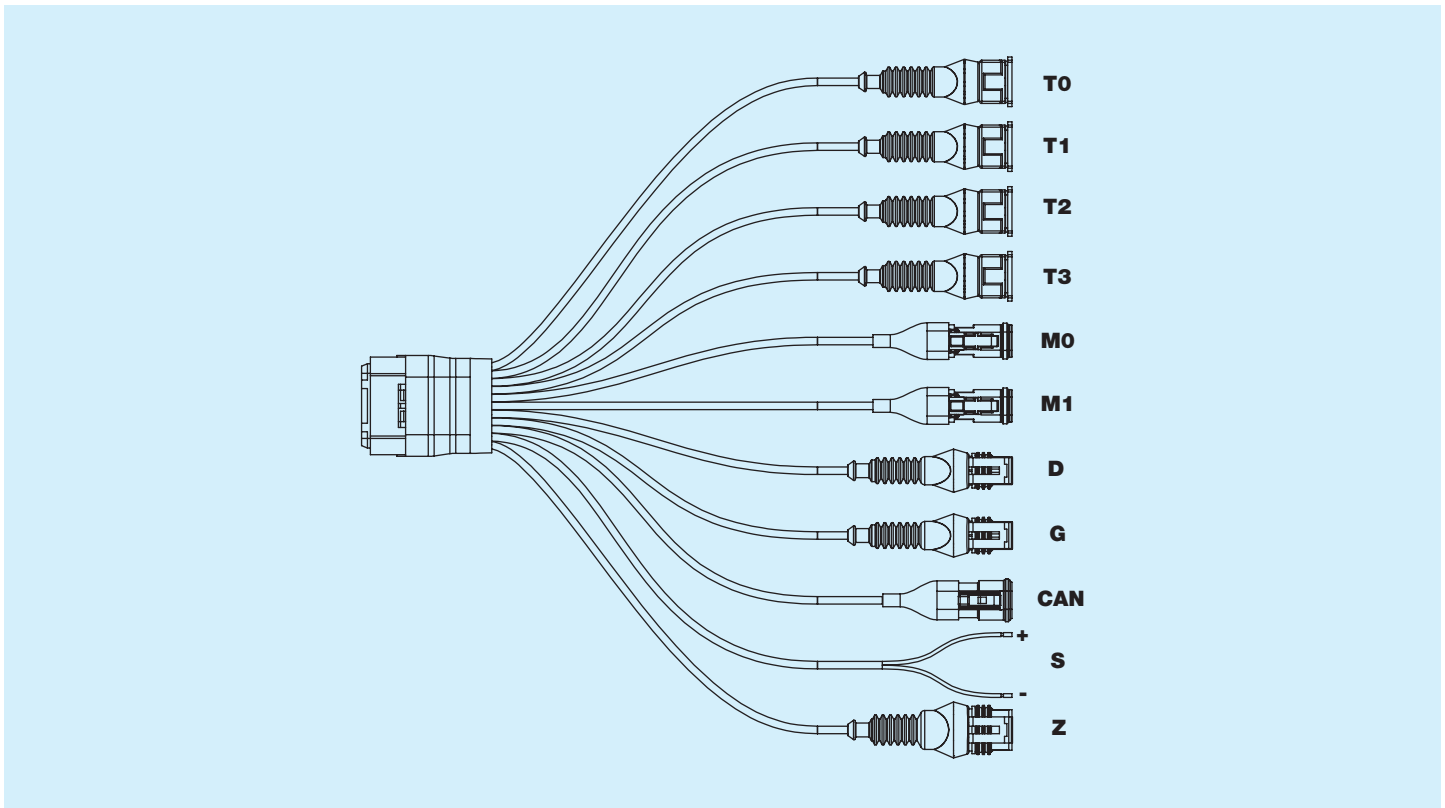

Connector	Function	Type	Lunghezza*
OUT T0	Temperature sensor	AMP JT 2-way (pin) seal version	200 ± 2 cm
OUT T1	Temperature sensor	AMP JT 2-way (pin) seal version	200 ± 2 cm
OUT T2	Temperature sensor	AMP JT 2-way (pin) seal version	200 ± 2 cm
OUT T3	Temperature sensor	AMP JT 2-way (pin) seal version	200 ± 2 cm
OUT M0	Forward valve	Deutsch 2-way (DT06-2S)	200 ± 2 cm
OUT M1	Reverse valve	Deutsch 2-way (DT06-2S)	200 ± 2 cm
OUT D	Input (e.g.: reverse request)	AMP Sseal 2-way (pin)	200 ± 2 cm
OUT G	Output (e.g.: lamp output)	AMP Sseal 2-way (pin)	200 ± 2 cm
OUT CAN	CAN Bus communication	Deutsch 3-way (DT06-3S)	200 ± 2 cm
OUT S	Power supply	2 separate contacts for pos./neg.	200 ± 2 cm
OUT Z	RS 232 communication	AMP Sseal 3-way (pin)	200 ± 2 cm

* from the two ends of the connector