

# MSM Series

## Electric motorwheels

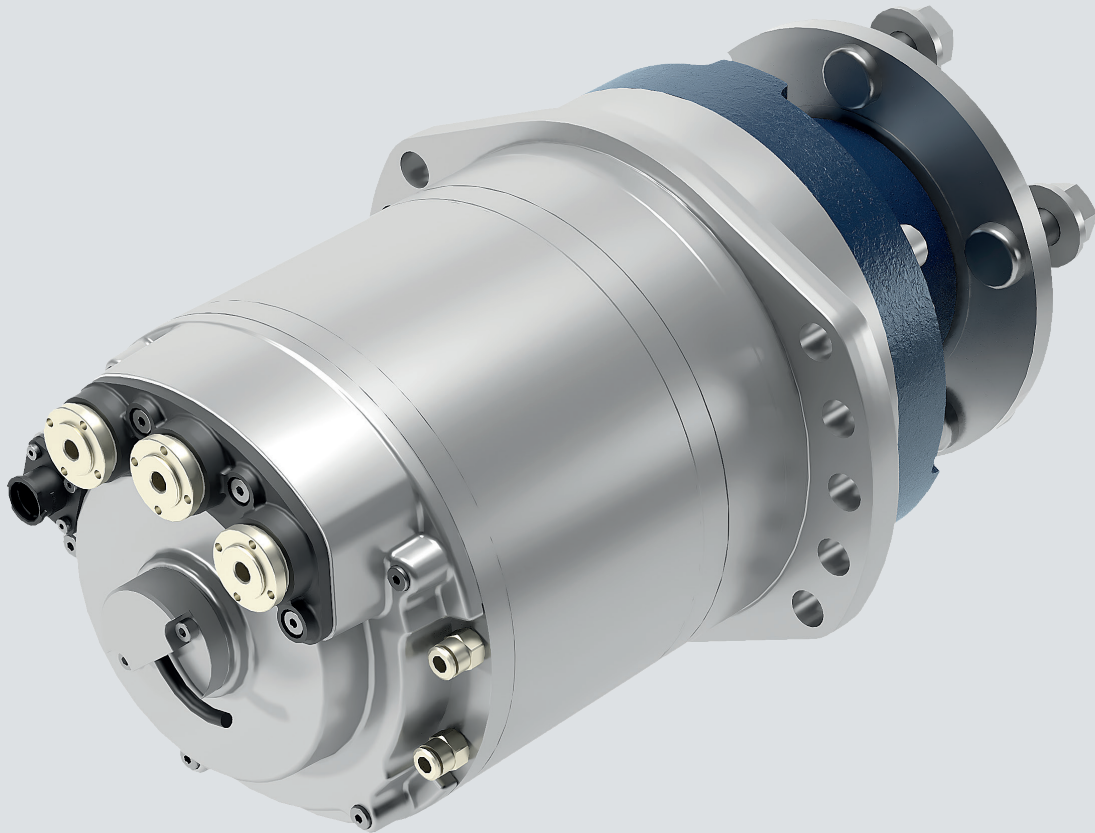

**SIBONI**  
A BONDIOLI & PAVESI COMPANY

398SEM004EN01 - 19-01-2026



---

MSM Series	5
MSM 050	6
MSM 075	8
MSM 100	10
Dimensions	12
Technical data	13
Output shafts	14
Brake - Connection - Thermal Sensor, Signal Pinout - Disengagement	16
Instructions for ordering	18

---

© SIBONI srl

No part of this manual may be reproduced without specific permission from Siboni.

This publication has been prepared with the utmost attention to precision and accuracy, but Siboni denies responsibility for any typographical errors or omission.

All data and codes contained in this catalog replace and supersede any information given by previous publications.

Consequently data provided in previous publications may no longer be valid. Siboni reserves the right to change specifications without prior notice or obligation.



## Electric Wheel Hub Motor for Off-Highway Applications

Our **wheel hub motor** combines a high-performance brushless electric motor with an integrated gearbox, specifically designed to accelerate the electrification of the **off-highway sector**. This innovative solution addresses the growing demand for sustainable mobility across agriculture, municipal vehicles, and construction machinery.

The motor has been **engineered to fit seamlessly inside the wheel**, ensuring maximum space efficiency while delivering **optimal power density**.

Its compact architecture minimizes overall dimensions, offering manufacturers greater freedom in vehicle design without compromising on performance.

To enhance safety and reliability, the unit comes with a **built-in parking brake**, complete with a **mechanical release system** for emergency operation in the event of vehicle failure.

This feature ensures uninterrupted functionality even in the toughest working conditions.

Designed for durability, the motor offers **robust construction and a high protection rating**, making it suitable for challenging environments where resistance to dust, water, and extreme conditions is essential.

Operating within a **48V power supply range**, the wheel hub motor is perfectly aligned with the needs of battery-powered equipment, combining efficiency, safety, and versatility.

This product sets a new standard in **electric traction solutions**, helping industries move toward a cleaner, smarter, and more efficient future.

### Torque/Speed Characteristics

#### Liquid Cooling

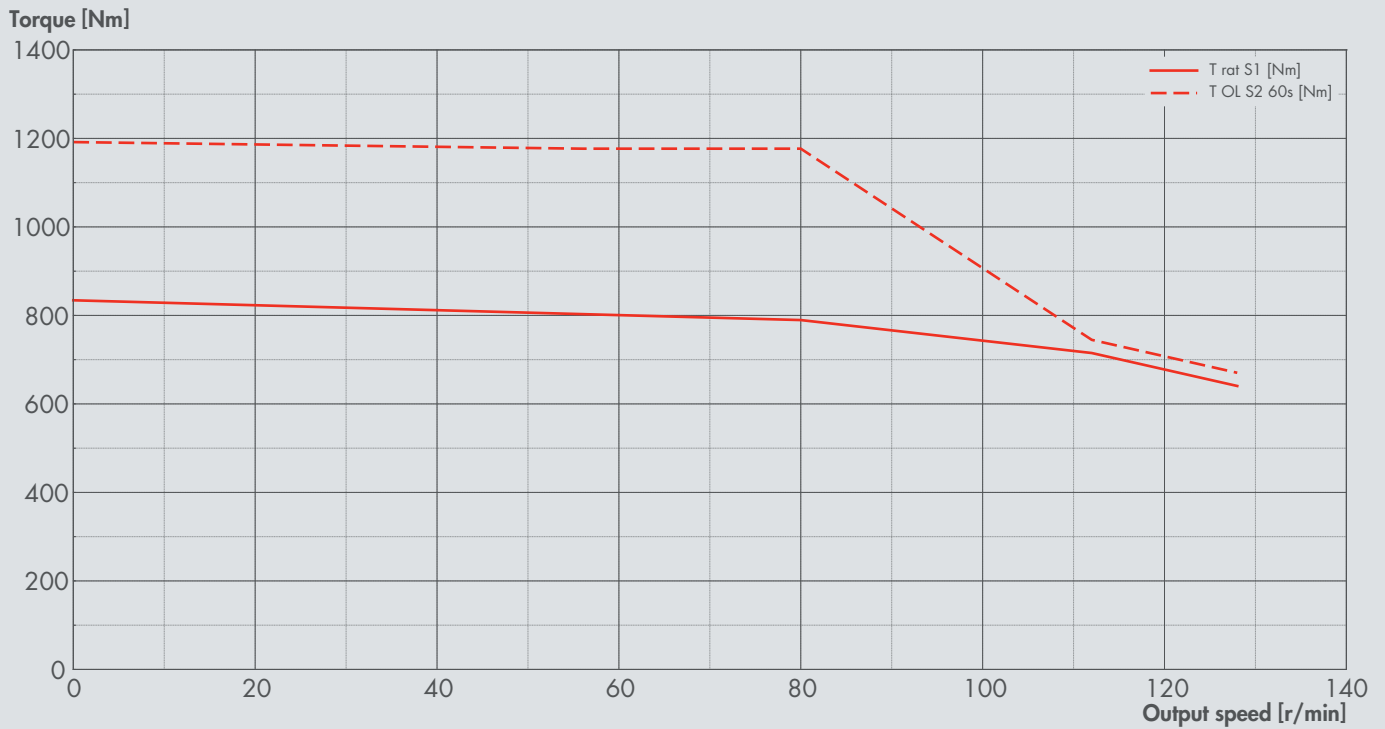

#### Air Cooling

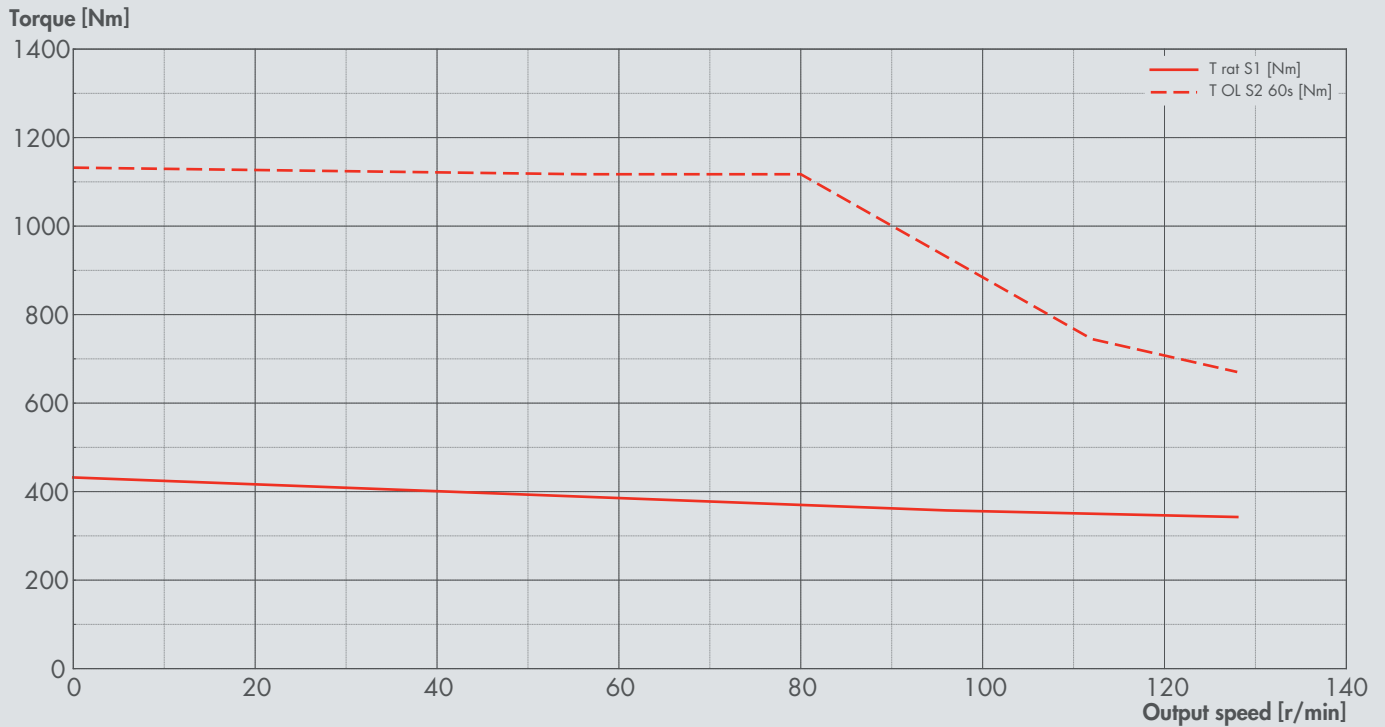

## Performance and specifications

MOTOR MODEL		MSM 050	
Reduction ratio		31.36	
Winding code		MSM187A	MSM182A
GENERAL DATA			
Cooling		Liquid	Air
Voltage Supply	$V_{dc}$	48	
Stall torque	$Nm$	835	430
Stall current	$A_{rms}$	209	116
Rated power	$kW$	8	3,5
Rated speed	$r/min$	95	
Rated torque	$Nm$	750	350
Rated current	$A_{rms}$	204	102
Peak torque	$Nm$	1170	1115
Peak current	$A_{rms}$	316	296
Torque constant $\pm 5\%$ (at 25°C)	$Nm/A_{rms}$	3,7	
Voltage constant $\pm 5\%$	$V_{rms}/[k(r/min)]$	8	
Winding Resistance Phase Phase $\pm 5\%$ (at 25°C)	$ohm$	8,6	
Winding Inductance Phase Phase $\pm 5\%$	$mH$	0,1	
Pole number		10	
$\Delta T_{MAX}$ Winding	$^{\circ}C$	105	
MECHANICAL DATA			
Mineral gearbox oil type		ISO VG 150/220 EP	
Mineral gearbox oil quantity	$ml$	400	
Weight	$kg$	35,5	
PARKING BRAKE (option)			
Rated voltage +6 / -10%	$V_{dc}$	24	
Rated current at 20°C	$A$	1,1	
Weight	$Kg$	1,6	
Holding torque	$Nm$	1100	
ROTOR POSITION SENSOR SIN-COS (single ended)			
Supply	$V$	5V +/- 5%	
Max current consumption	$mA$	30	
Internal serial impedance	$Ohm$	100	
Amplitude	$V$	2.2 +/- 0.2 Vpp	
Signal offset	$V$	2.5 +/- 1%	
THERMAL SENSOR PT1000			
Type		PT1000-R8/2-2F	
Resistance at 20° / Resistance at 100°	$Ohm$	1078 / 1385	
Precision	$^{\circ}C$	+/- (0.3-0.005t)	

## Torque/Speed Characteristics

### Liquid Cooling

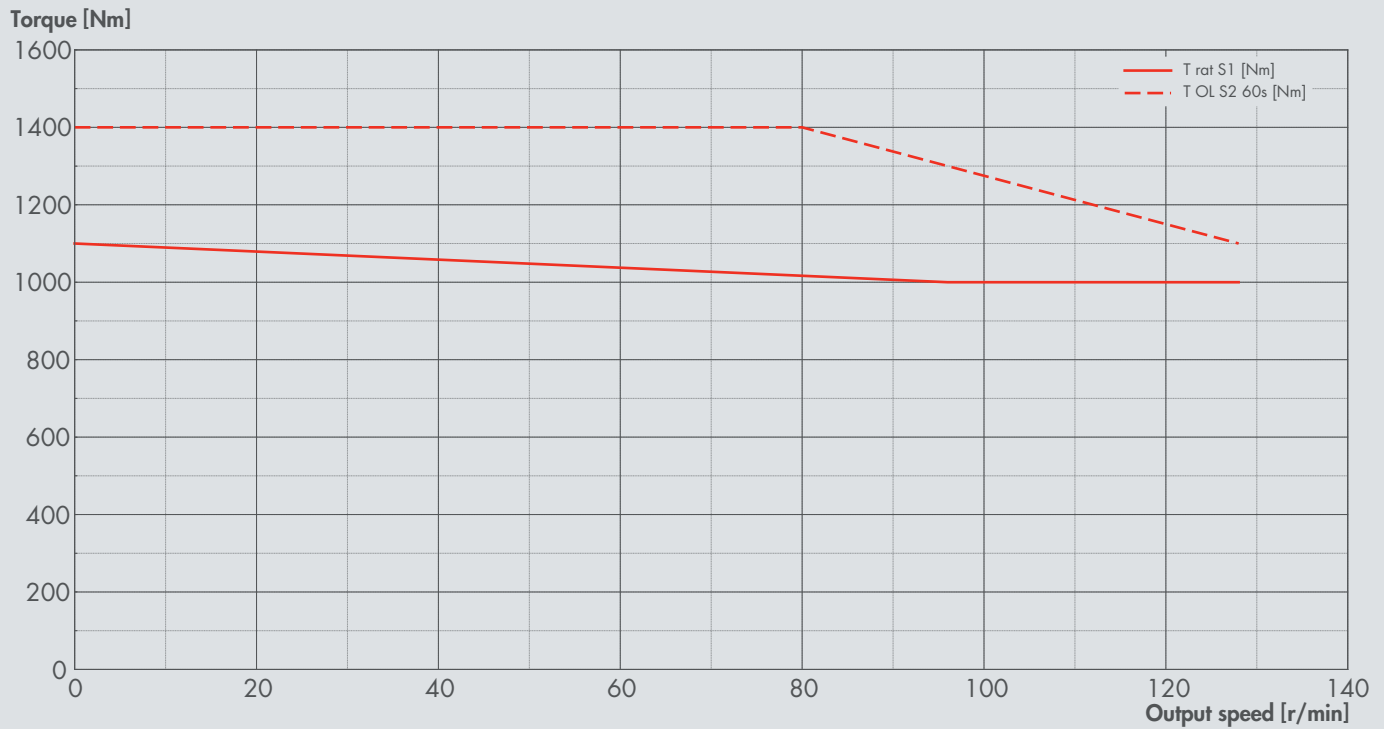

### Air Cooling

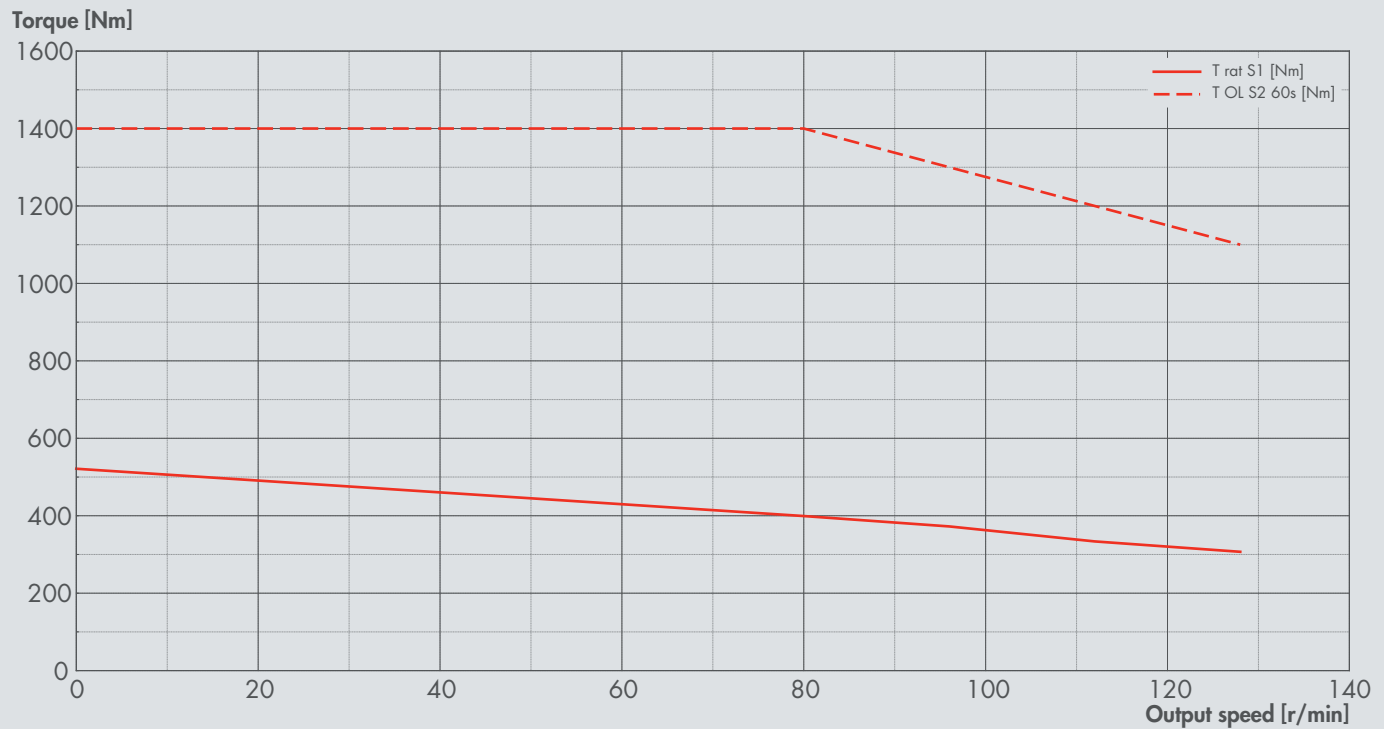

## Performance and specifications

MOTOR MODEL		MSM 075	
Reduction ratio		31.36	
Winding code		MSM188A	MSM183A
GENERAL DATA			
Cooling		Liquid	Air
Voltage Supply	$V_{dc}$	48	
Stall torque	$Nm$	1100	520
Stall current	$A_{rms}$	295	150
Rated power	$kW$	11	4
Rated speed	$r/min$	96	
Rated torque	$Nm$	1000	370
Rated current	$A_{rms}$	314	111
Peak torque	$Nm$	1400	
Peak current	$A_{rms}$	390	
Torque constant $\pm 5\%$ (at 25°C)	$Nm/A_{rms}$	3,7	
Voltage constant $\pm 5\%$	$V_{rms}/[k(r/min)]$	7,75	
Winding Resistance Phase Phase $\pm 5\%$ (at 25°C)	$ohm$	4,9	
Winding Inductance Phase Phase $\pm 5\%$	$mH$	0,06	
Pole number		10	
$\Delta T_{MAX}$ Winding	$^{\circ}C$	105	
MECHANICAL DATA			
Mineral gearbox oil type		ISO VG 150/220 EP	
Mineral gearbox oil quantity	$ml$	400	
Weight	$kg$	38,5	
PARKING BRAKE (option)			
Rated voltage +6 / -10%	$V_{dc}$	24	
Rated current at 20°C	$A$	1,1	
Weight	$Kg$	1,6	
Holding torque	$Nm$	1100	
ROTOR POSITION SENSOR SIN-COS (single ended)			
Supply	$V$	5V +/- 5%	
Max current consumption	$mA$	30	
Internal serial impedance	$Ohm$	100	
Amplitude	$V$	2.2 +/- 0.2 Vpp	
Signal offset	$V$	2.5 +/- 1%	
THERMAL SENSOR PT1000			
Type		PT1000-R8/2-2F	
Resistance at 20° / Resistance at 100°	$Ohm$	1078 / 1385	
Precision	$^{\circ}C$	+/- (0.3-0.005t)	

## Torque/Speed Characteristics

### Liquid Cooling

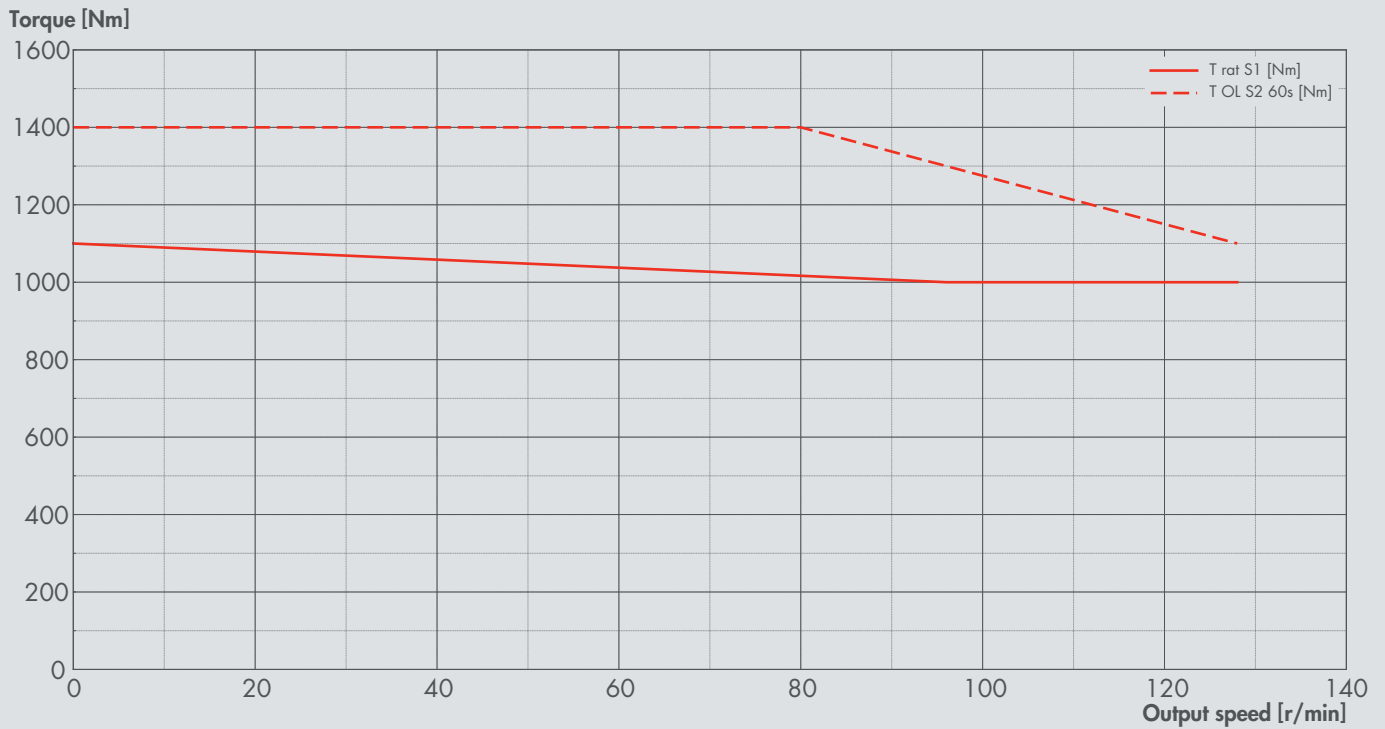

### Air Cooling

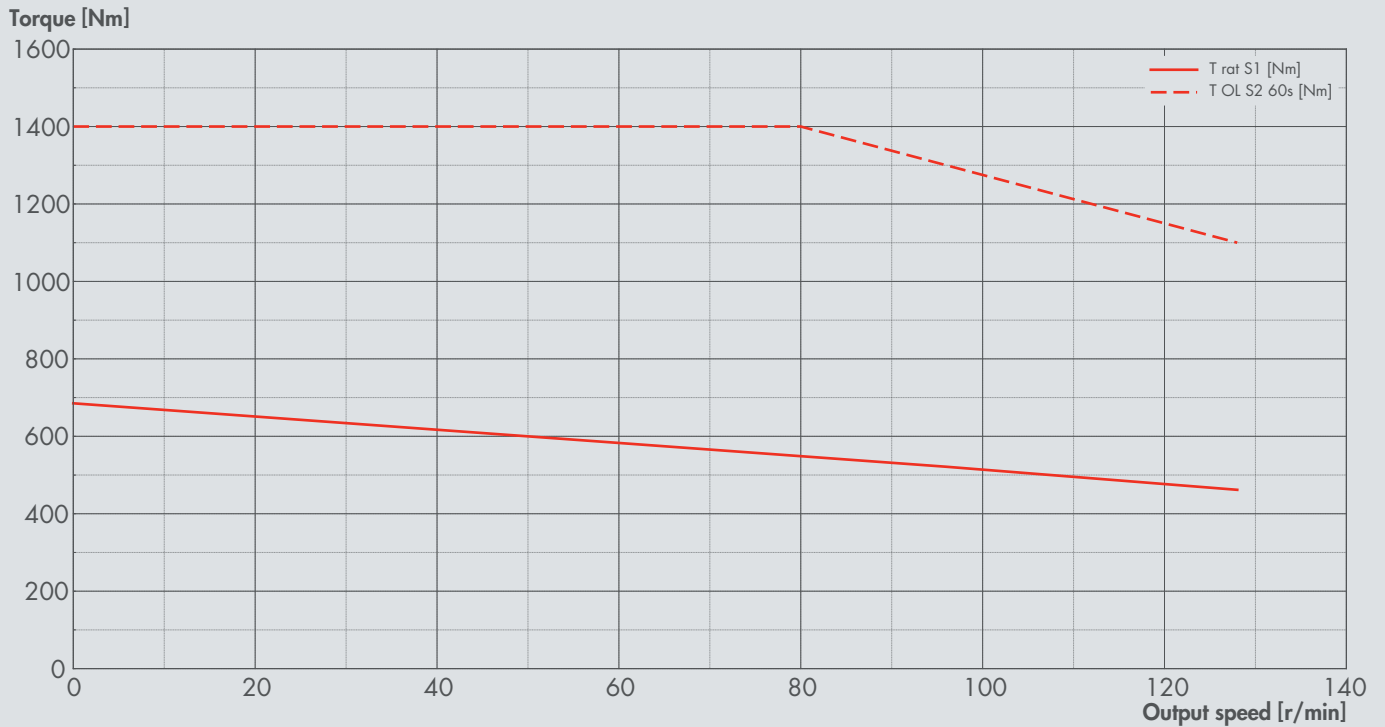

## Performance and specifications

MOTOR MODEL		MSM 100	
Reduction ratio		31.36	
Winding code		MSM189A	MSM184A
GENERAL DATA			
Cooling		Liquid	Air
Voltage Supply	$V_{dc}$	48	
Stall torque	$Nm$	1100	680
Stall current	$A_{rms}$	275	183
Rated power	$kW$	16	5,5
Rated speed	$r/min$	96	
Rated torque	$Nm$	1000	520
Rated current	$A_{rms}$	305	147
Peak torque	$Nm$	1400	
Peak current	$A_{rms}$	360	
Torque constant $\pm 5\%$ (at 25°C)	$Nm/A_{rms}$	3,7	
Voltage constant $\pm 5\%$	$V_{rms}/[k(r/min)]$	8,25	
Winding Resistance Phase Phase $\pm 5\%$ (at 25°C)	$ohm$	3,8	
Winding Inductance Phase Phase $\pm 5\%$	$mH$	0,05	
Pole number		10	
$\Delta T_{MAX}$ Winding	$^{\circ}C$	105	
MECHANICAL DATA			
Mineral gearbox oil type		ISO VG 150/220 EP	
Mineral gearbox oil quantity	$ml$	400	
Weight	$kg$	42,5	
PARKING BRAKE (option)			
Rated voltage +6 / -10%	$V_{dc}$	24	
Rated current at 20°C	$A$	1,1	
Weight	$Kg$	1,6	
Holding torque	$Nm$	1100	
ROTOR POSITION SENSOR SIN-COS (single ended)			
Supply	$V$	5V +/- 5%	
Max current consumption	$mA$	30	
Internal serial impedance	$Ohm$	100	
Amplitude	$V$	2.2 +/- 0.2 Vpp	
Signal offset	$V$	2.5 +/- 1%	
THERMAL SENSOR PT1000			
Type		PT1000-R8/2-2F	
Resistance at 20° / Resistance at 100°	$Ohm$	1078 / 1385	
Precision	$^{\circ}C$	+/- (0.3-0.005t)	

### AIR COOLING

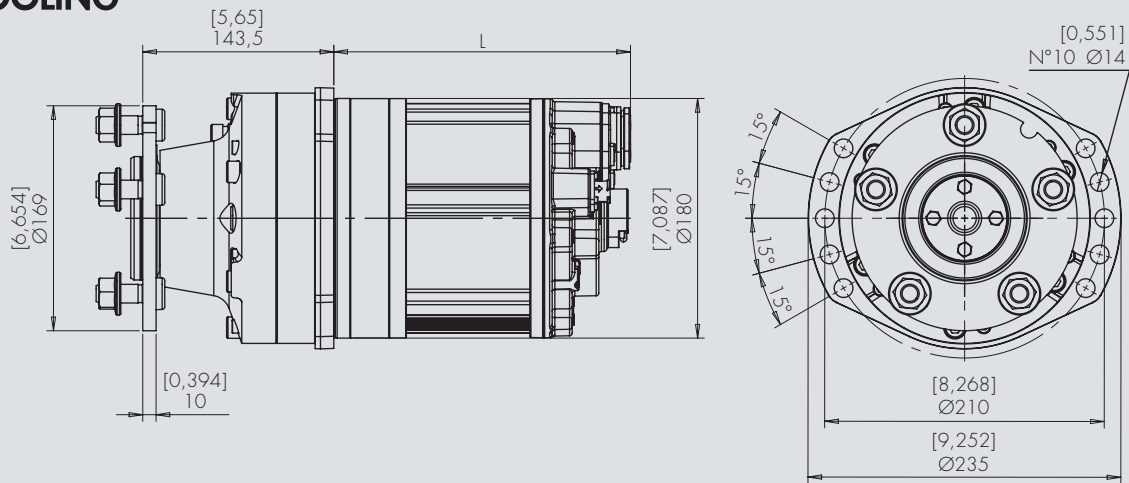

### LIQUID COOLING

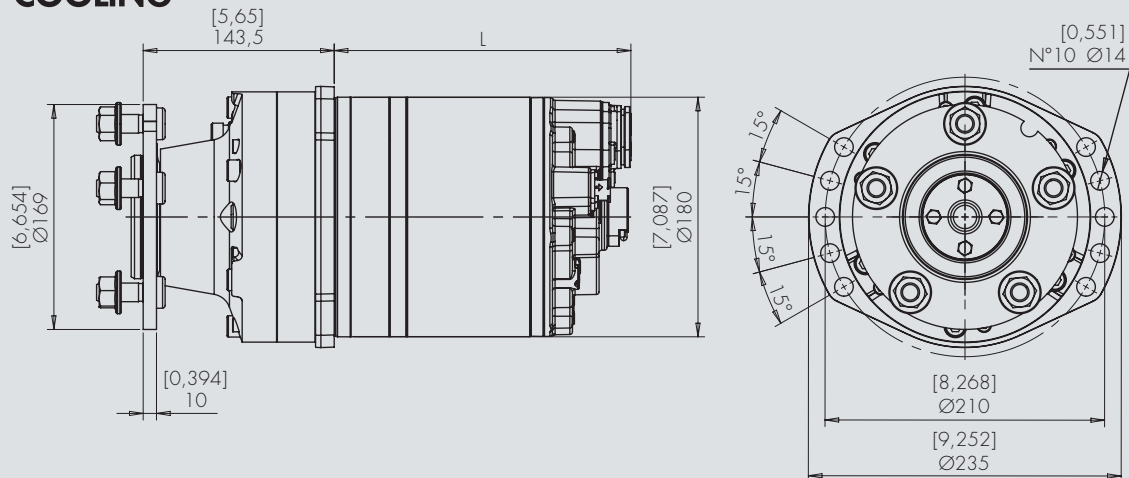

SIZE	L	
	mm	inch
EMX 050	223	8,8
EMX 075	248	9,8
EMX 100	273	10,7

Radial load and service life of bearings

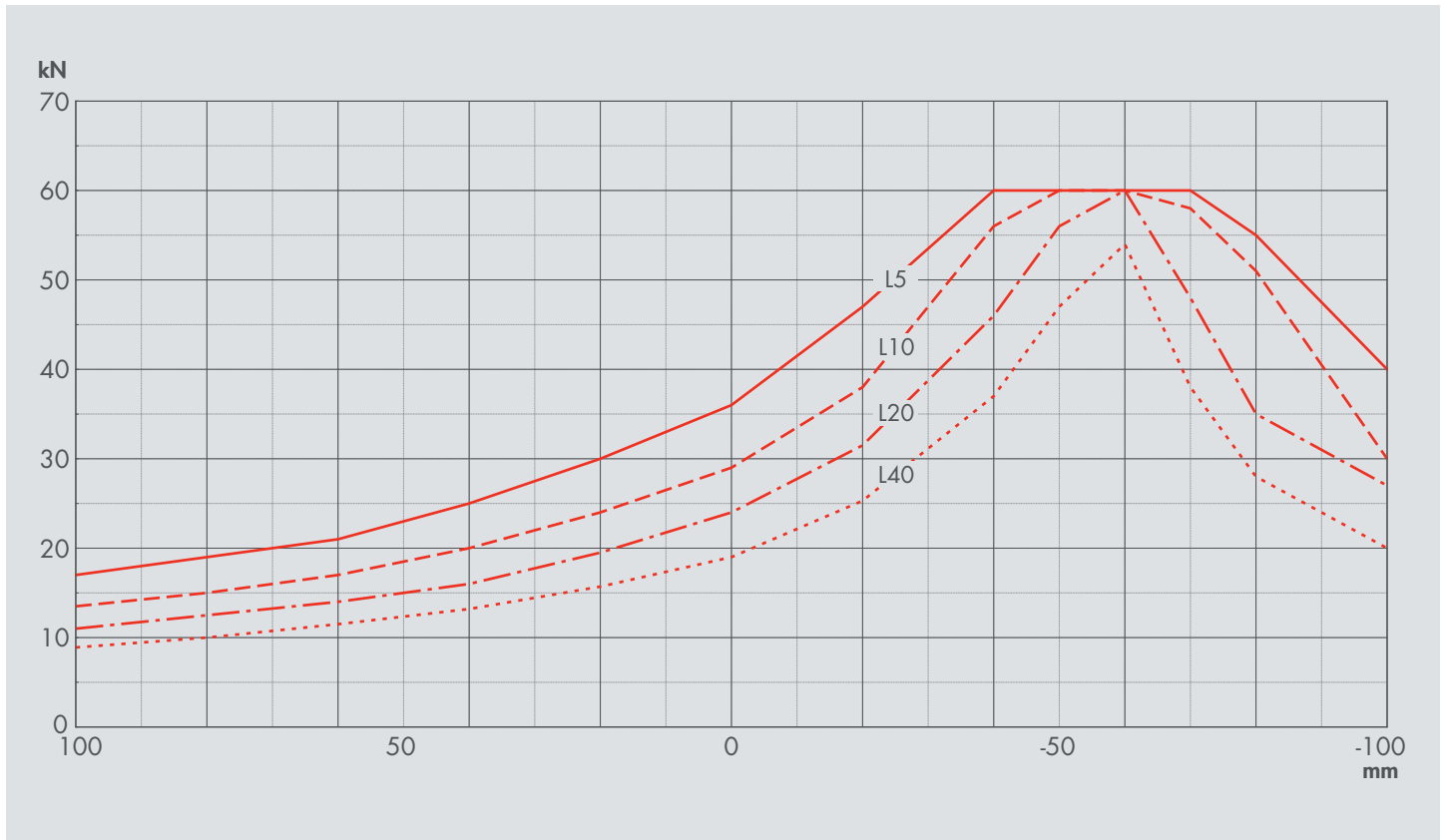

The curves of the permissible radial loads  $F_r$ , as a function of the abscissa  $x$  (distance from the wheel mounting surface), show the value corresponding to the service life  $L$  in millions of cycles of the bearings, calculated on the basis of ISO281.

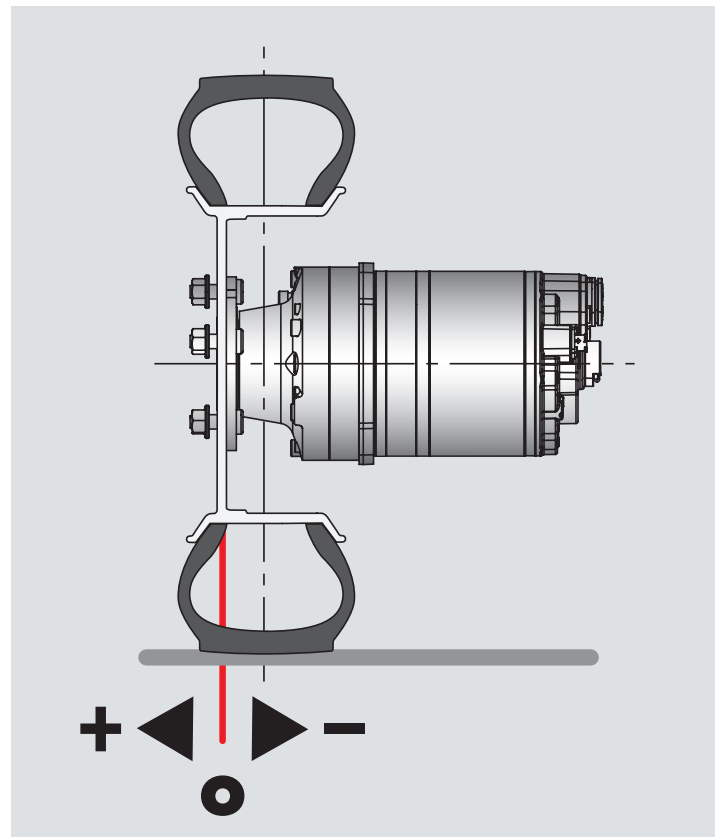

**R** Back (wheel)

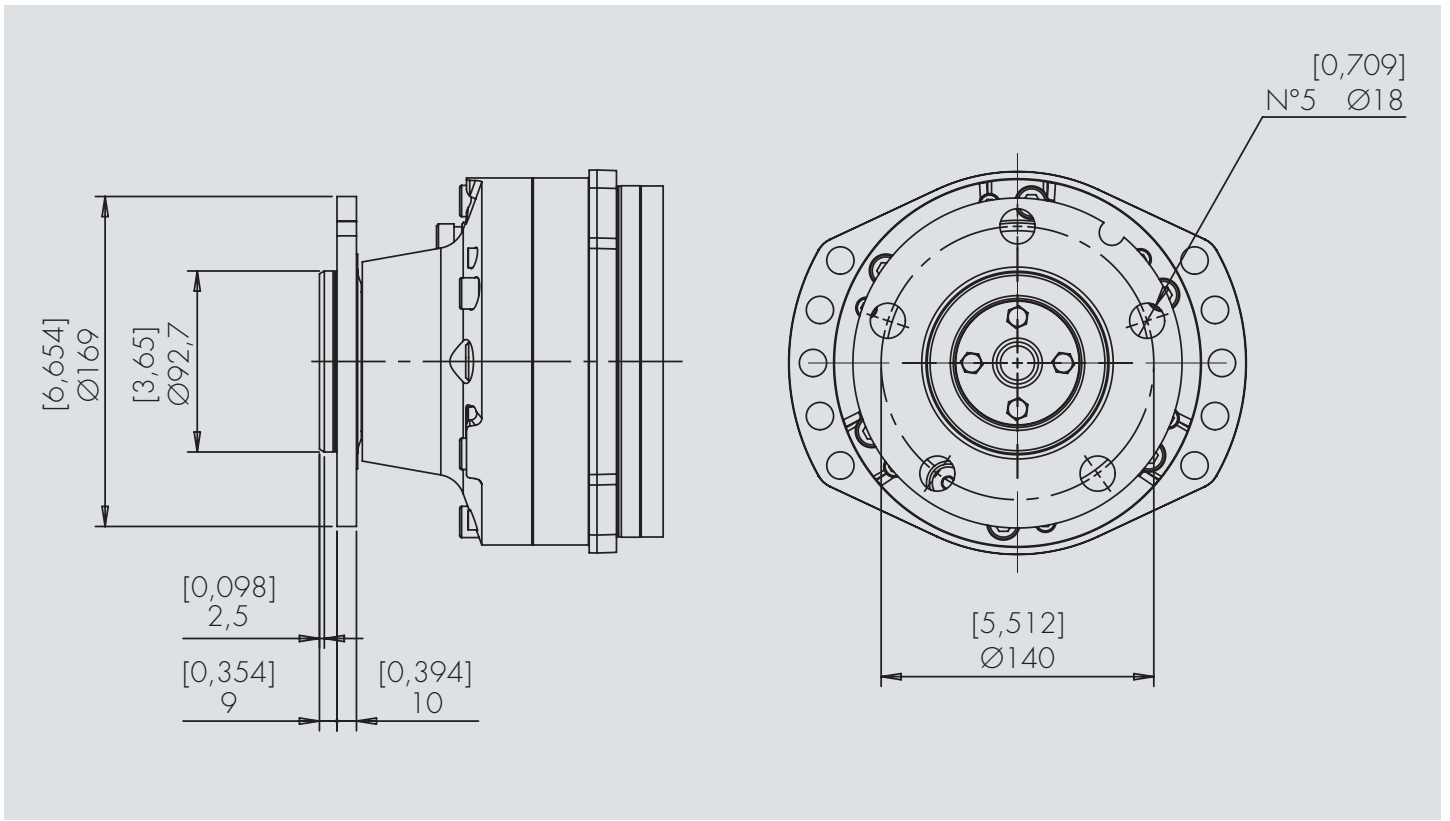

**1** Back (wheel with studs)

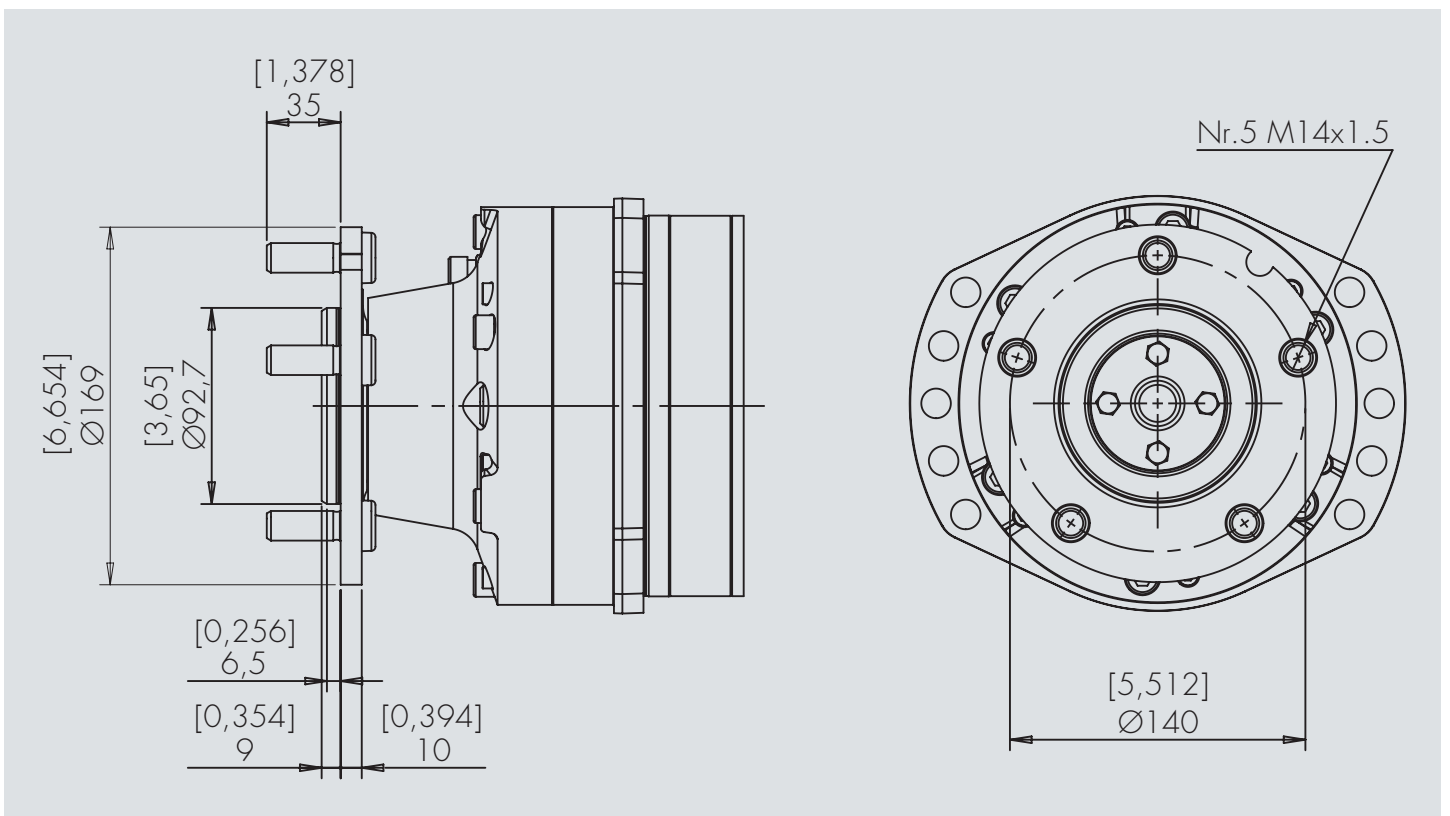

**2** Back (wheel with studs+bolts)

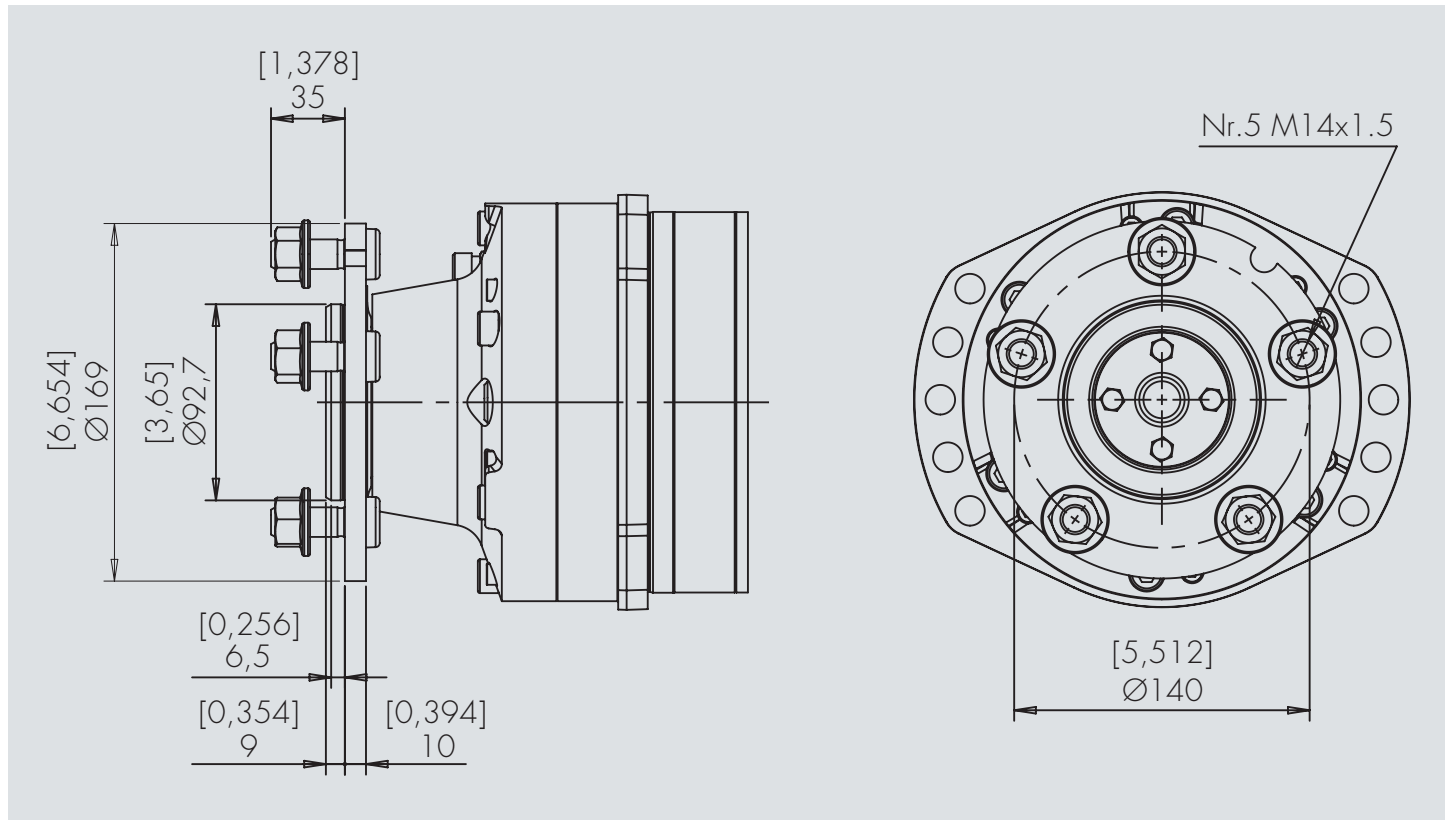

**E** Shaft DIN 5480 W50x2x30x24

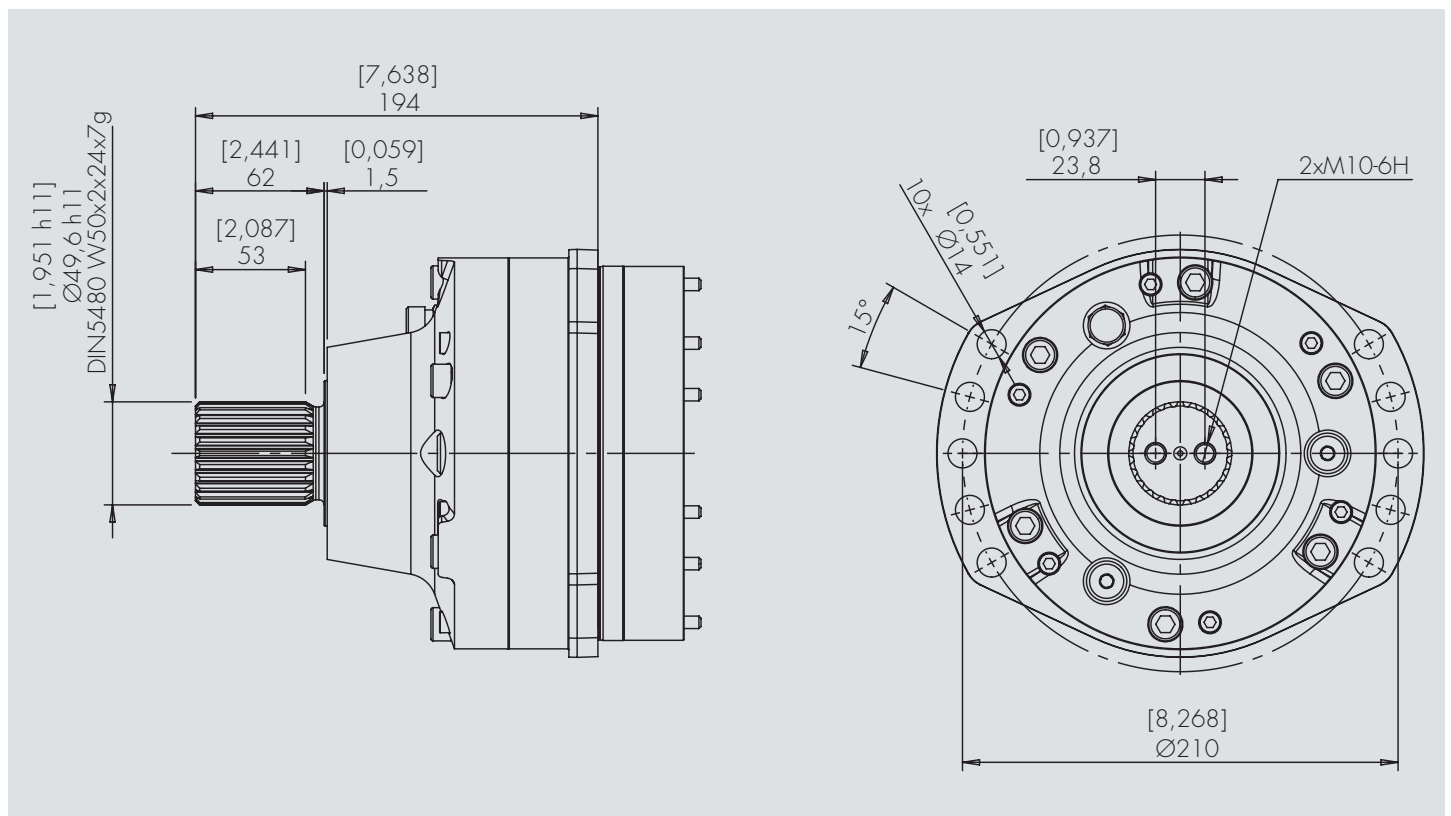

**0** Amphenol FLS010N2P03-PM

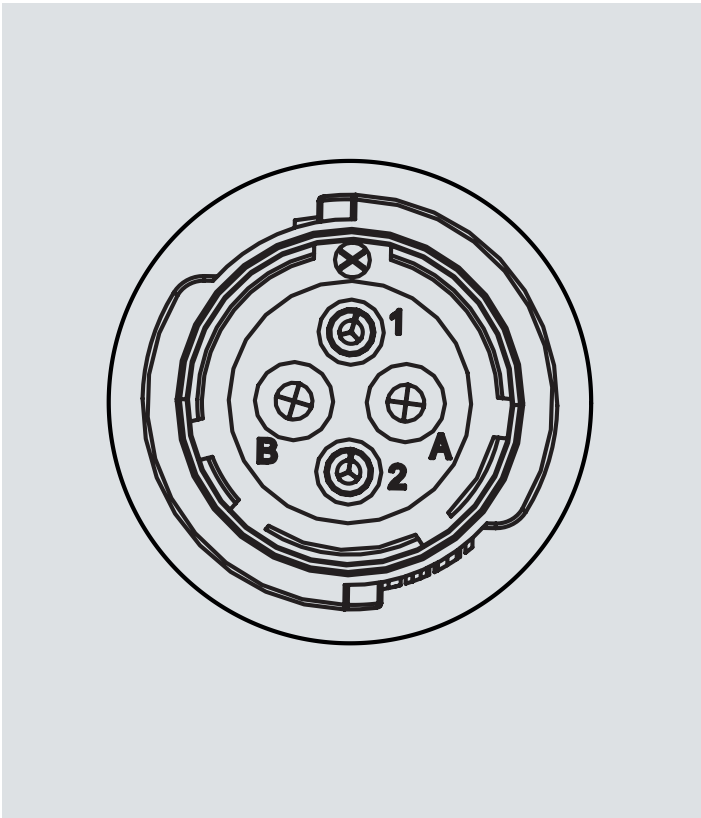

Pin	Signal
1	PT1000
3	
A	Brake V+
B	Brake V-

\*Counterpart Mating Female Plug Housing Amphenol FLS610N2SHEC03

Power connection

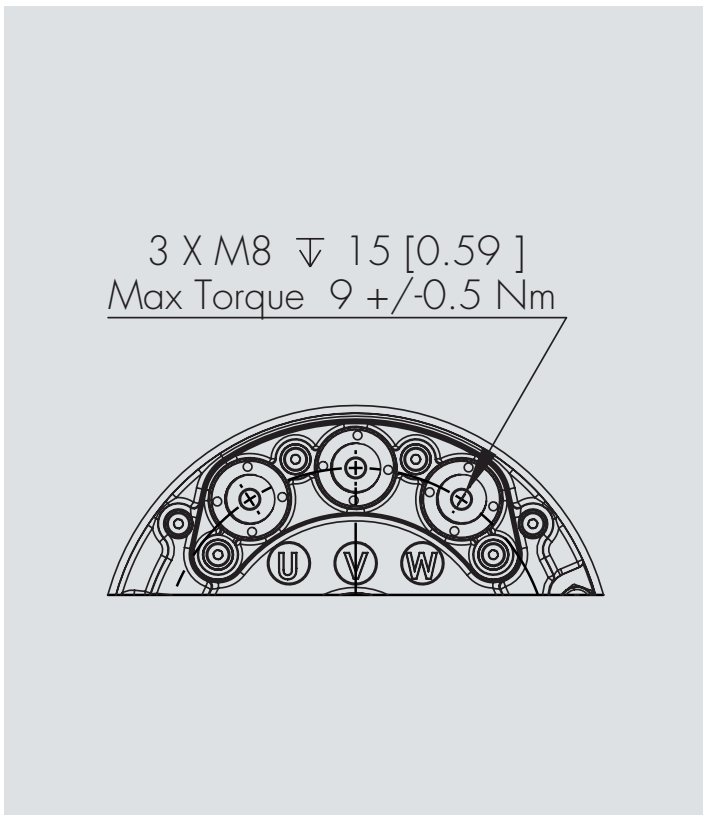

Superseal 4 poles sin/cos encoder AMP 282106-1\*

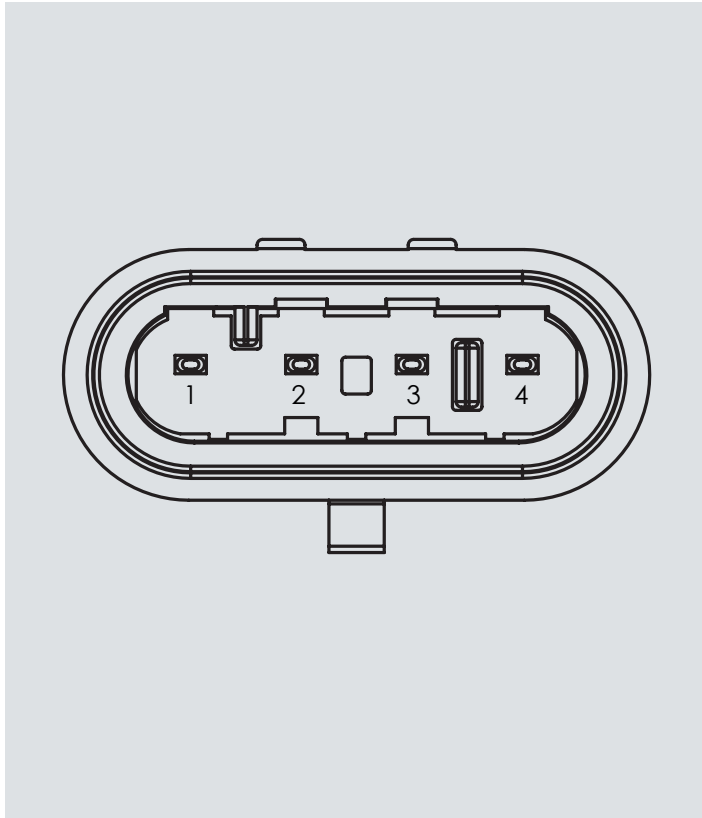

Pin	Signal
1	Vin+
2	COS out
3	SIN out
4	GND

\*Counterpart Mating Female Plug Housing AMP 282088-1

**Y** Towing disengagement

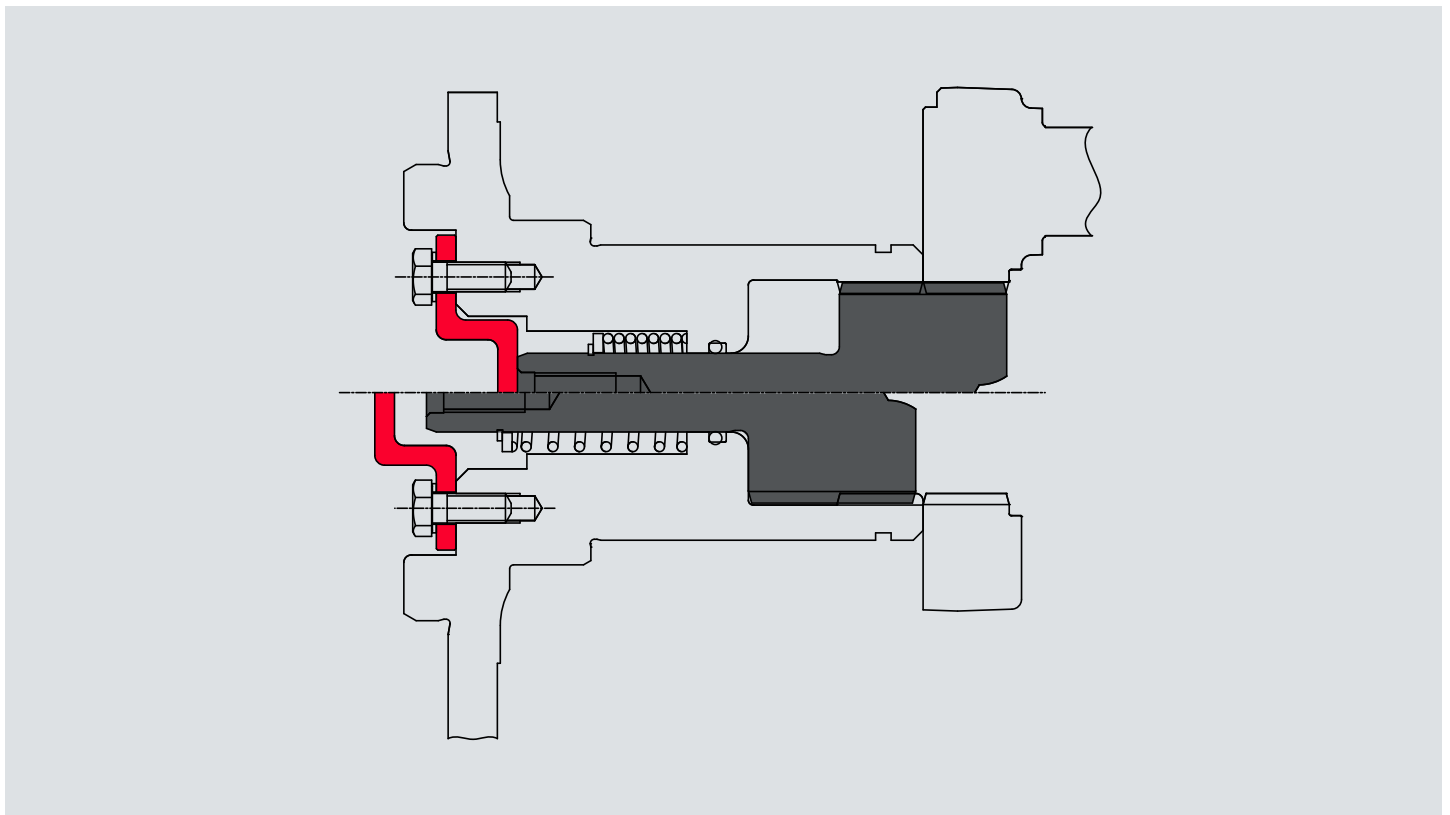

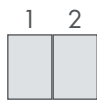

Motor dimension

**18**



Motor/Cooling type

**2** MSM 050 - air cooled    **3** MSM 075 - air cooled    **4** MSM 100 - air cooled    **7** MSM 050 - liquid cooled  
**8** MSM 075 - liquid cooled    **9** MSM 100 - liquid cooled



Power configuration

**A** 48V



Encoder

**1** Sin/Cos



Cable outlet

**A** Rear



Reduction ratio

**A** 1:31 (3 planet gears)    **B** B = 1:31 (4 planet gear)



Output connection

**X** Rotary flange



Output Shaft

**R** Back (wheel)    **1** Back (wheel with studs)    **2** Back (wheel with studs+bolts)    **E** Shaft DIN 5480 W50x2x30x24

10

Parking brake

**A** 36Nm EM

**N** No brake

11

Dynamic brake

**N** No brake

12

Towing disengagement

**Y**

13 14 15

Customization

**001** No varnishing

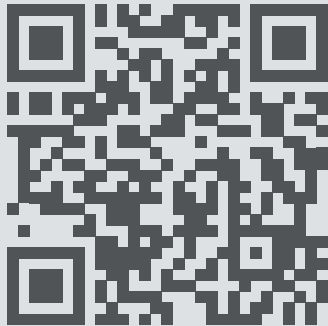

**SIBONI**  
A BONDIOLI & PAVESI COMPANY