

## HPR 系列 2 电机

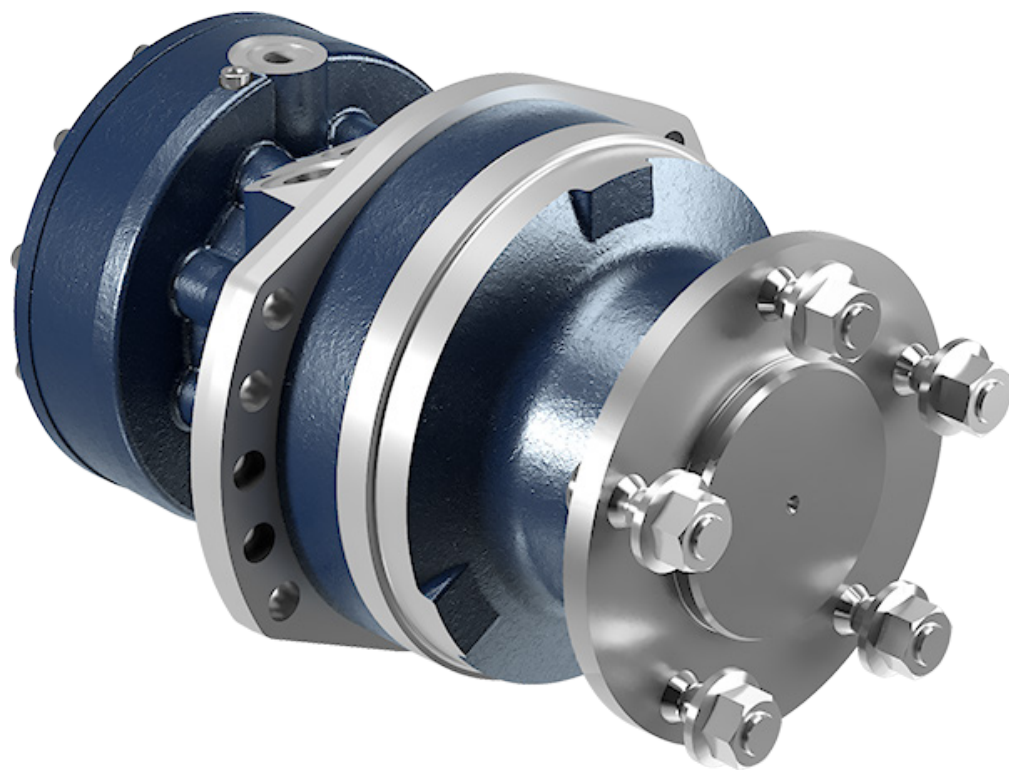

开始使用前，请仔细阅读文件《闭式轴向柱塞泵和电机使用一般说明》。

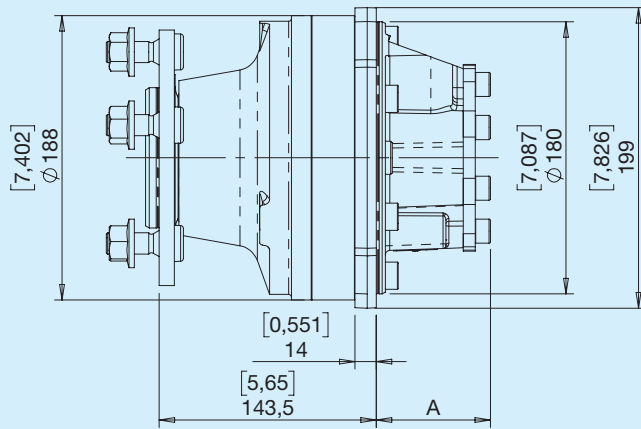

电动轮版本

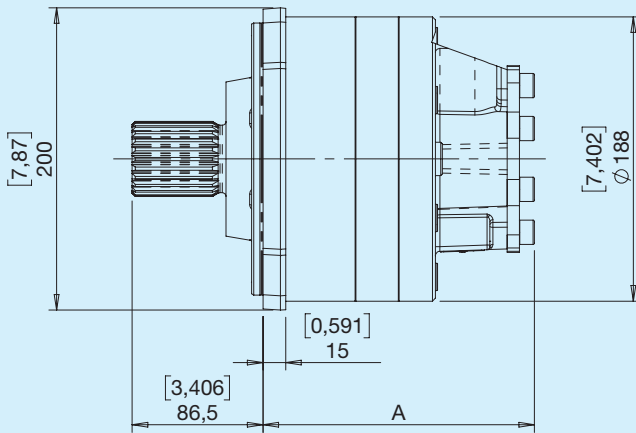
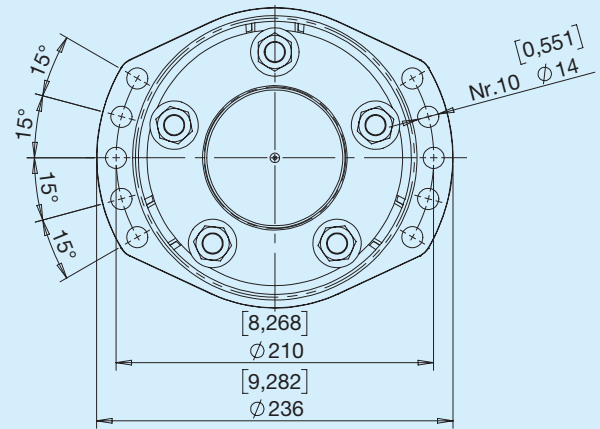

花键轴版本

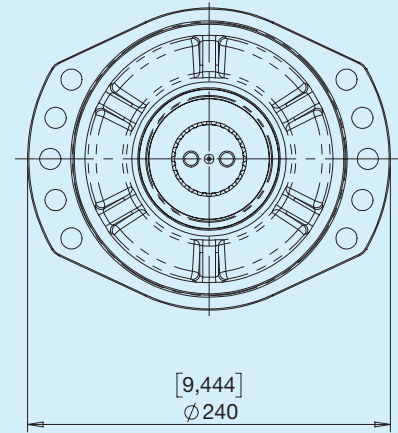

HPR2	理论位移				转速		工作压力		最大功率		Massa	
	固定/ 1档		2档		固定/ 1档	2档	psi		固定/ 1档	2档	kg	lbs
	cm <sup>3</sup>	in <sup>3</sup>	cm <sup>3</sup>	in <sup>3</sup>	RPM	RPM	5800	psi	kW	kW		
<b>210</b>	212	12.94	<b>106</b>	6.47	470	470	5510	6525	18	12	33	73
<b>230</b>	235	14.34	<b>118</b>	7.20	435	435	450	6525	18	12	33	73
<b>260</b>	260	15.87	<b>130</b>	7.93	390	390	450	6525	18	12	33	73
<b>330</b>	332	20.26	<b>166</b>	10.13	265	336	400	5800	22	16	33	73
<b>360</b>	366	22.33	<b>183</b>	11.17	245	311	400	5800	22	16	33	73
<b>400</b>	402	24.53	<b>201</b>	12.27	220	279	400	5800	22	16	33	73

## R 后 (轮)

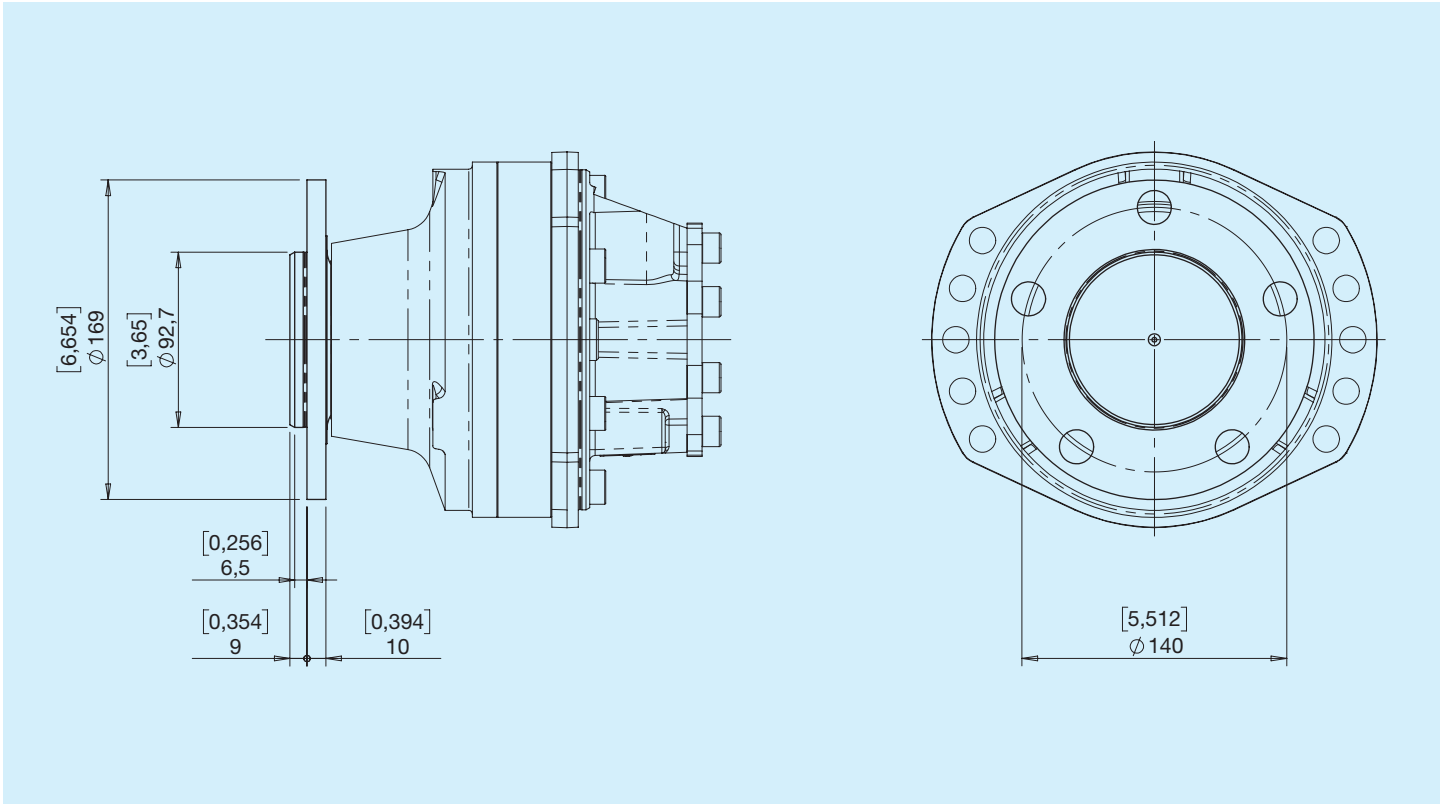

## 1 后 (带螺钉的轮子)

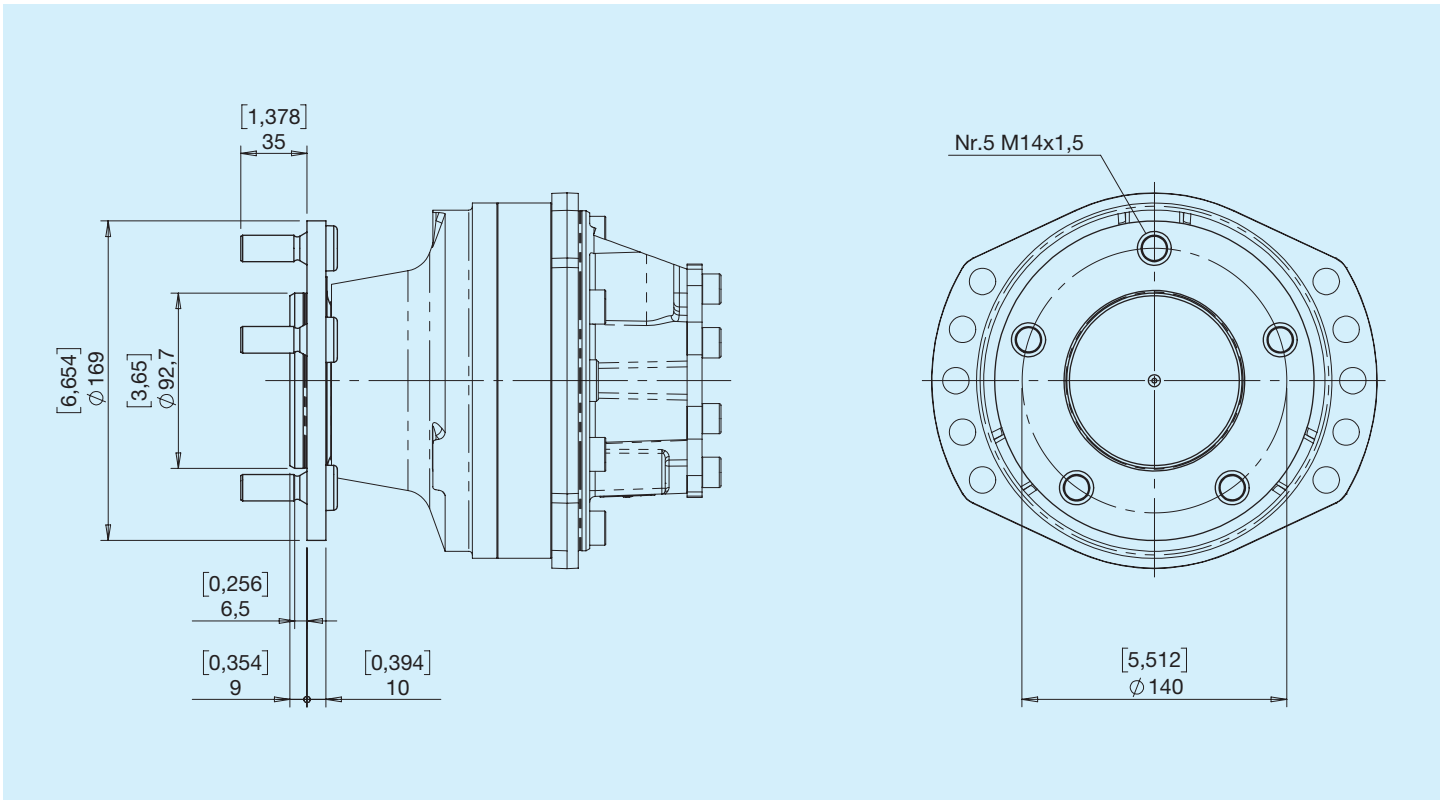

## 2 后 (带螺钉和螺母的轮子)

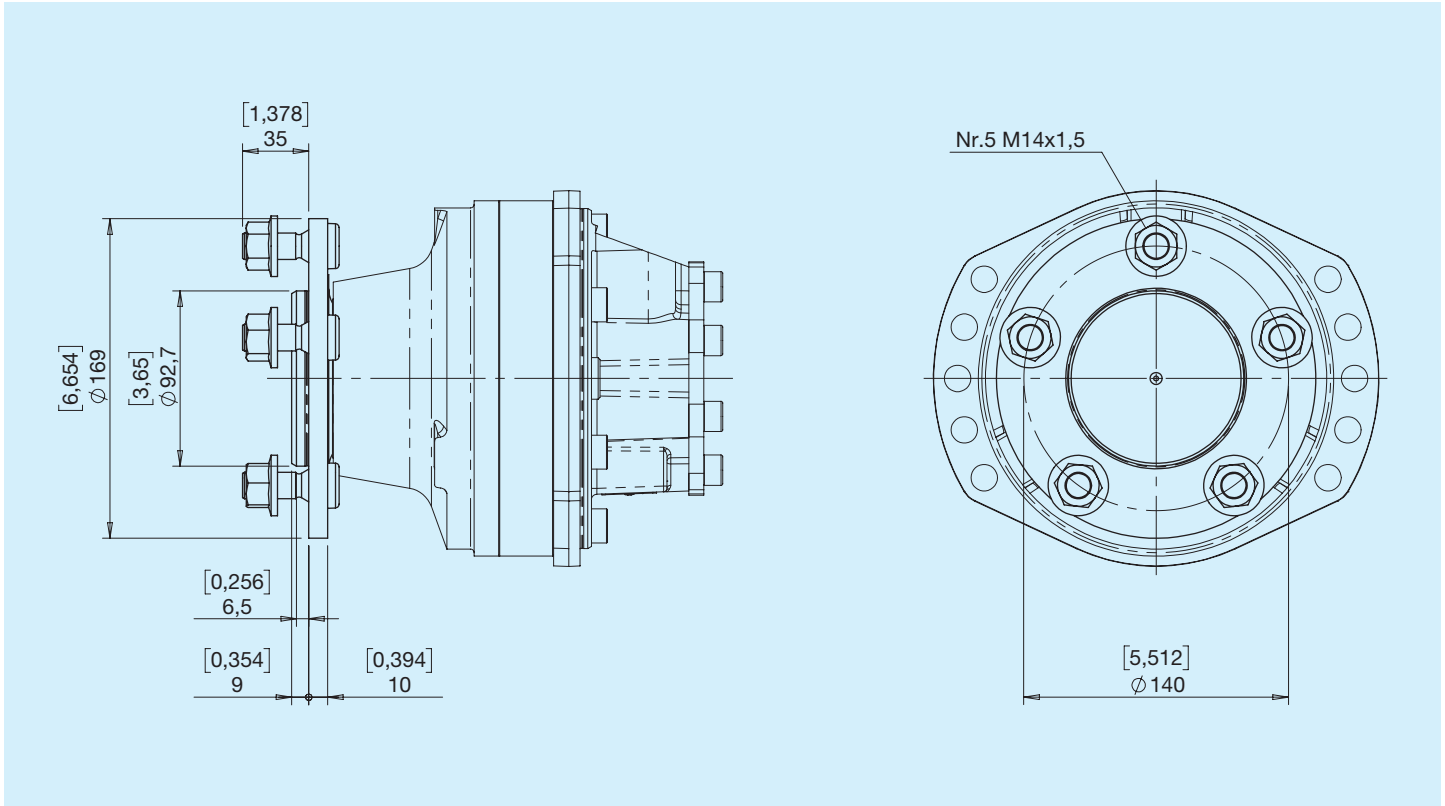

## E 轴 DIN 5480 W50x2x30x24

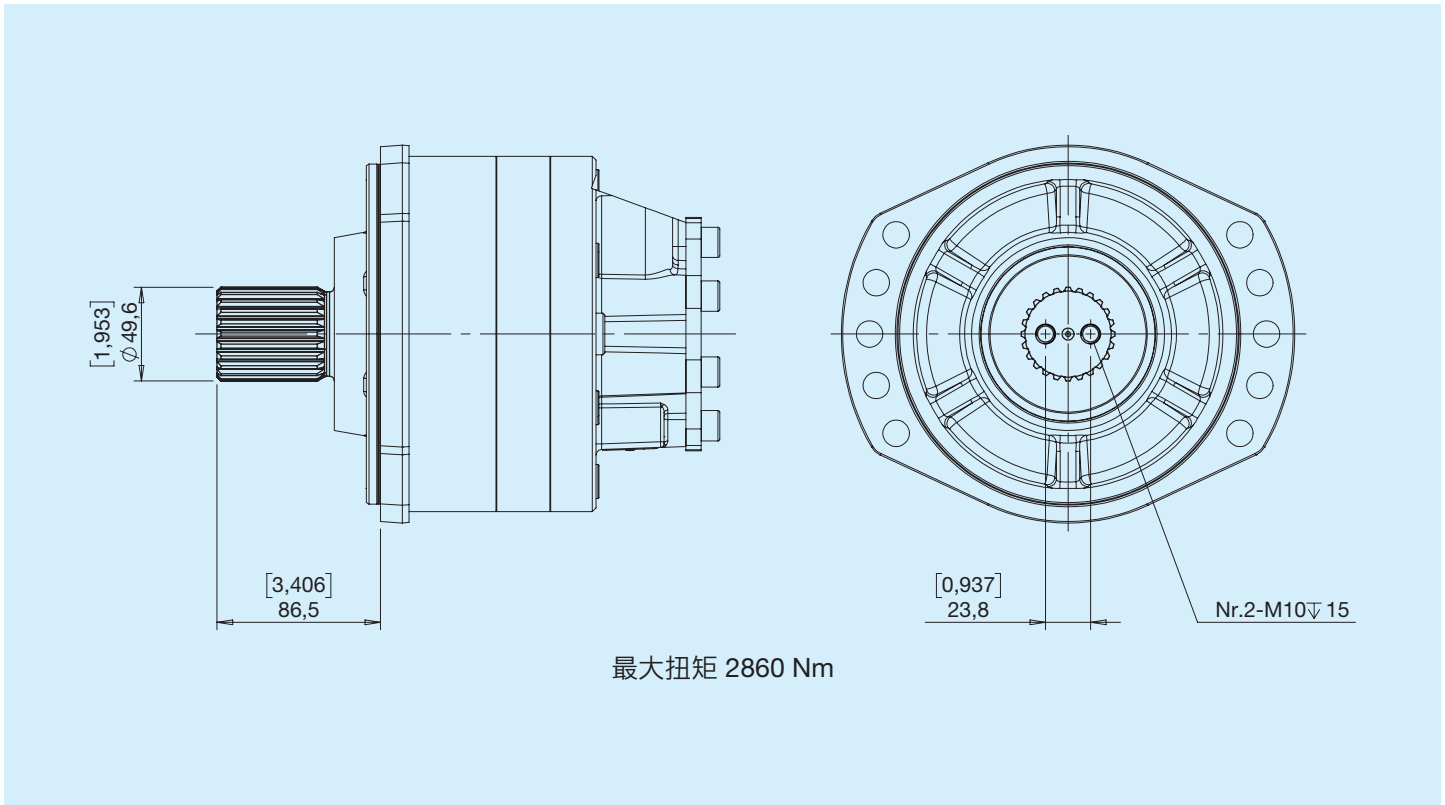

## G 型

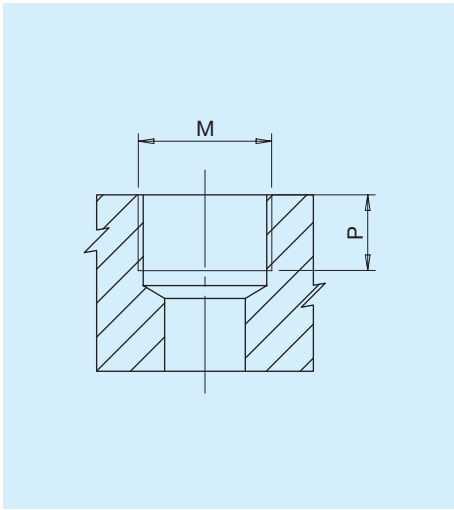

类型	M		P	
		Nm	mm	in
G2	端口 ISO 1179-1 - G 1/4	17	15	0.59
G3	端口 ISO 1179-1 - G 3/8	38	12.5	0.49
G4	端口 ISO 1179-1 - G 1/2	70	15	0.59

## U 型

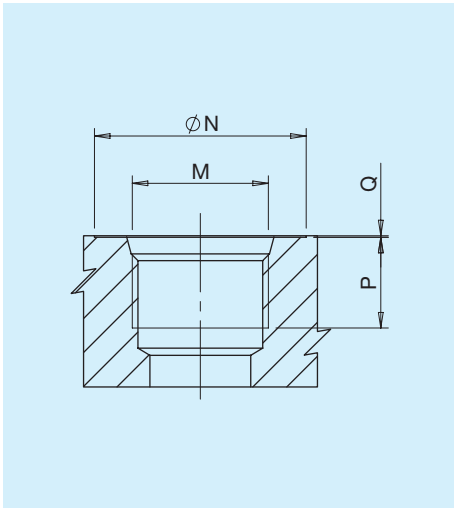

类型	尺寸	N		P		Q		M	
		mm	in	mm	in	mm	in		Nm
U2	1/4'	21	0.83	12	0.47	0.3	0.01	端口 ISO 11926-1 - 7/16-20	17
U3	3/8'	26	1.02	15	0.59	0.3	0.01	端口 ISO 11926-1 - 9/16-18	38
U4	1/2'	30	1.18	15	0.59	0.3	0.01	端口 ISO 11926-1 - 3/4-16	47

## 组合

类型	Input/Output A-B	排水 L1-L2	位移变化 Y	制动松开 X
<b>G</b>	G7	G3	G6	G2
<b>U</b>	U7	U3	U6	U2

**FC** 固定无制动

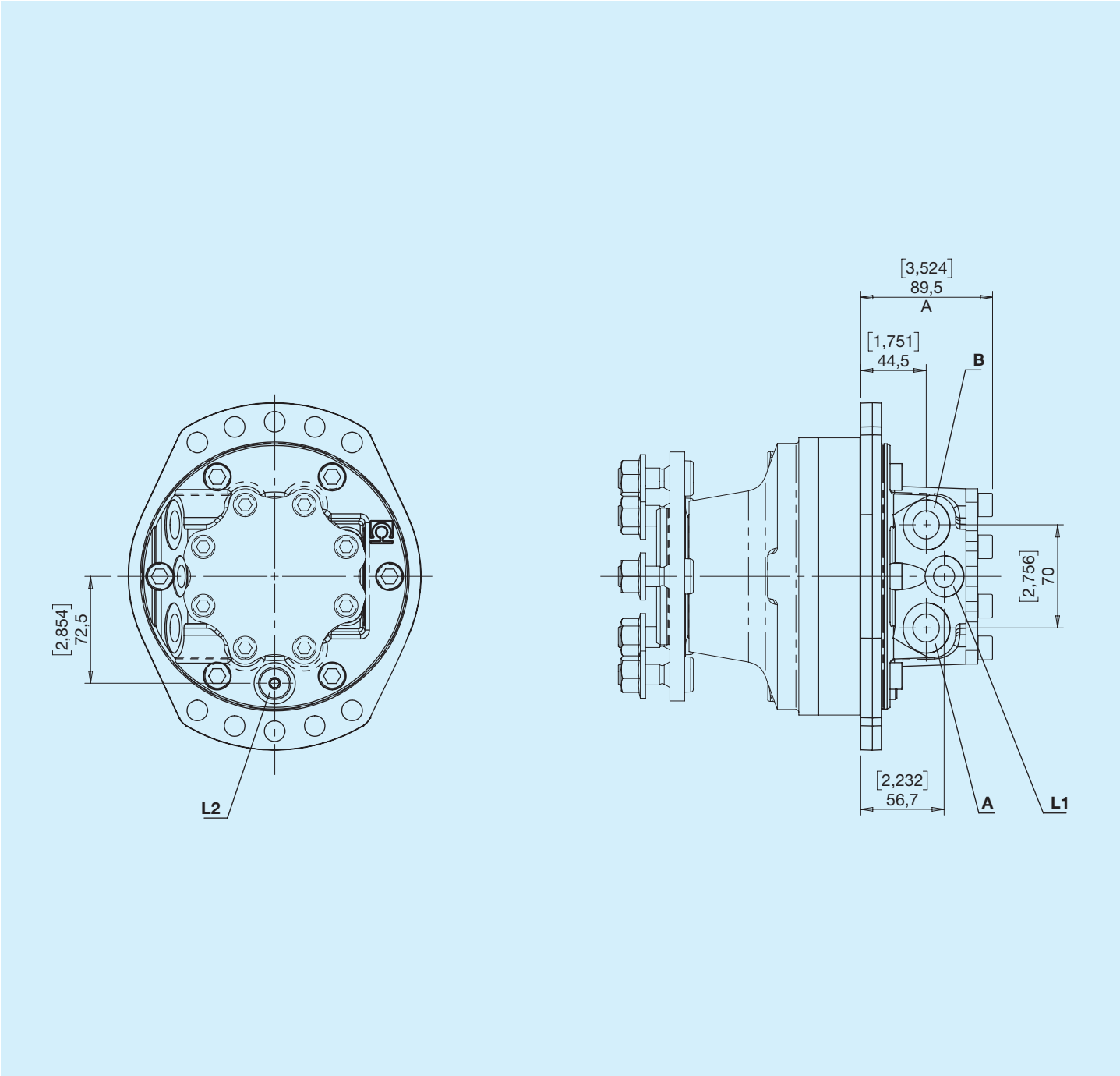

## FF 固定带制动

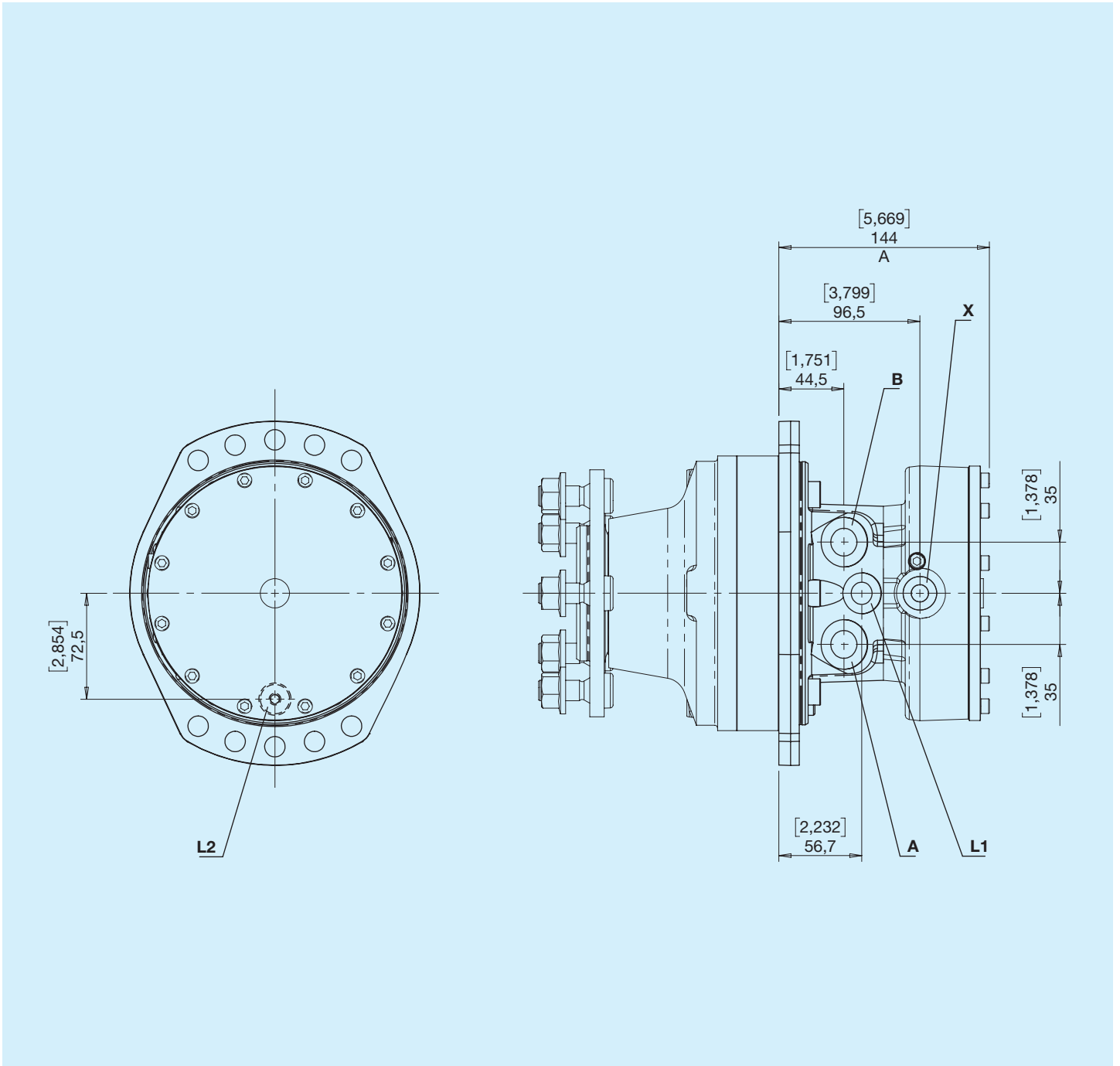

**VC** 2 档无制动

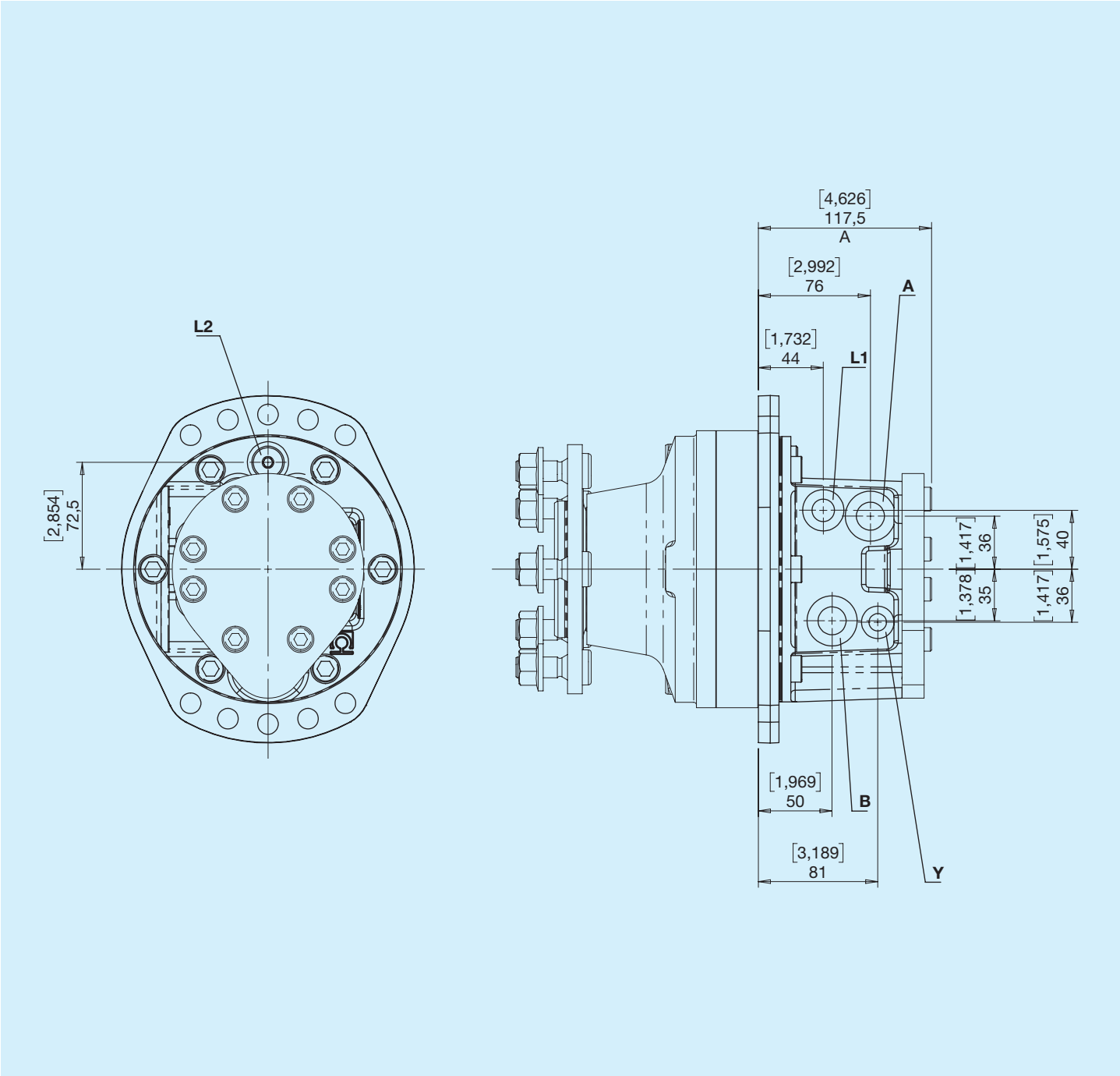



## VF 2 档带制动

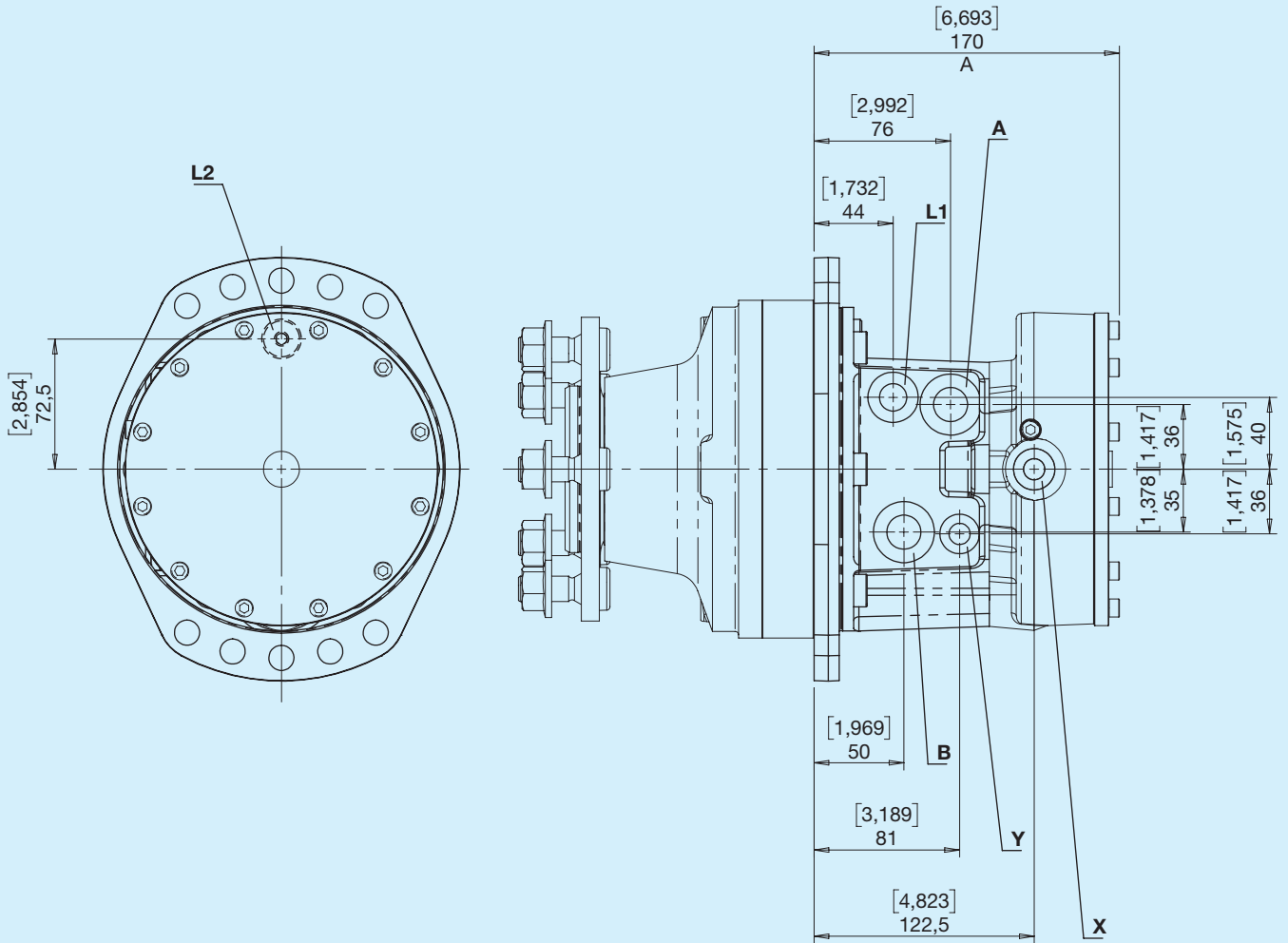

**AC** 固定无制动

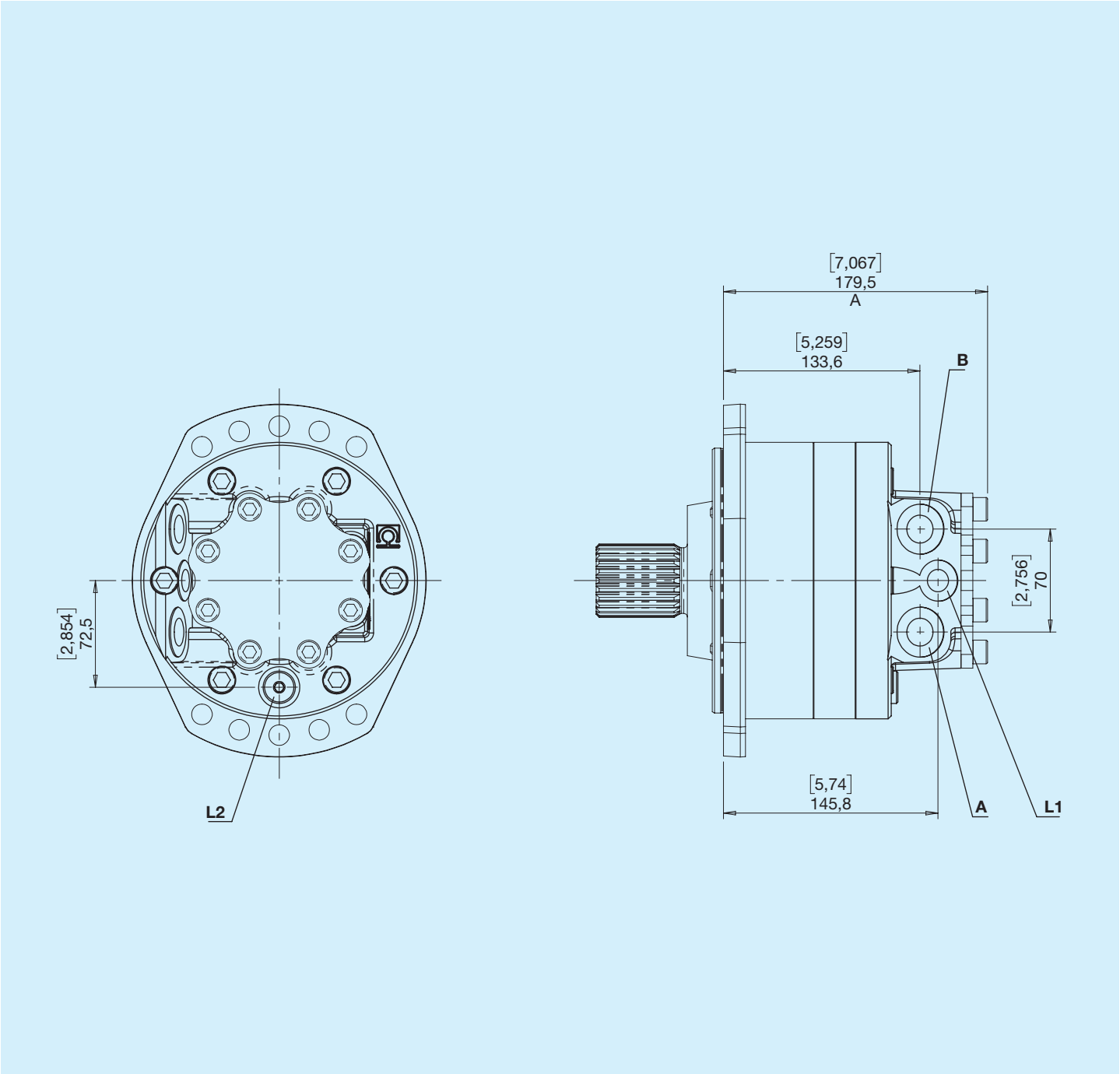

## AF 带制动固定

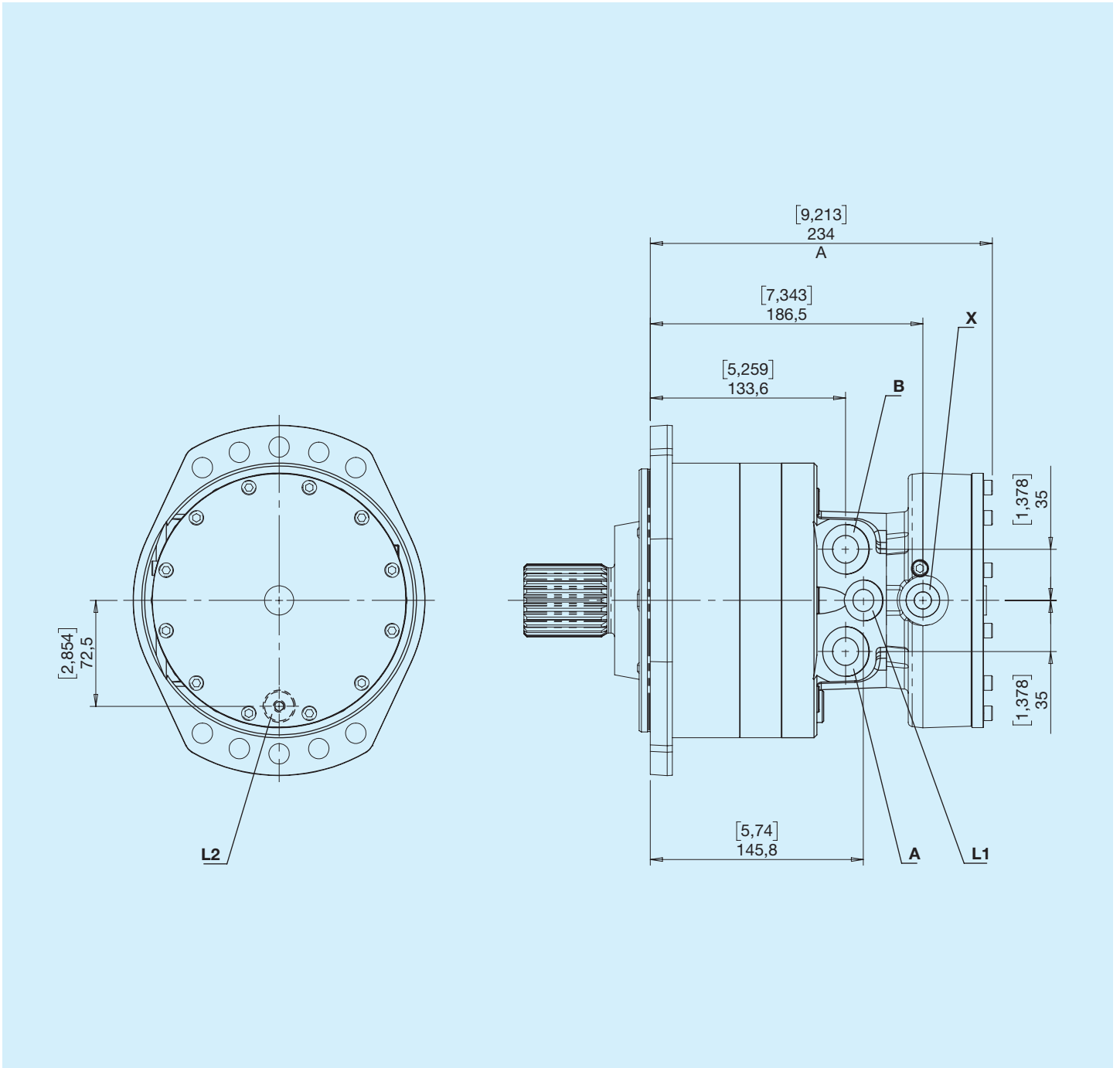

**WC** 2 档无制动

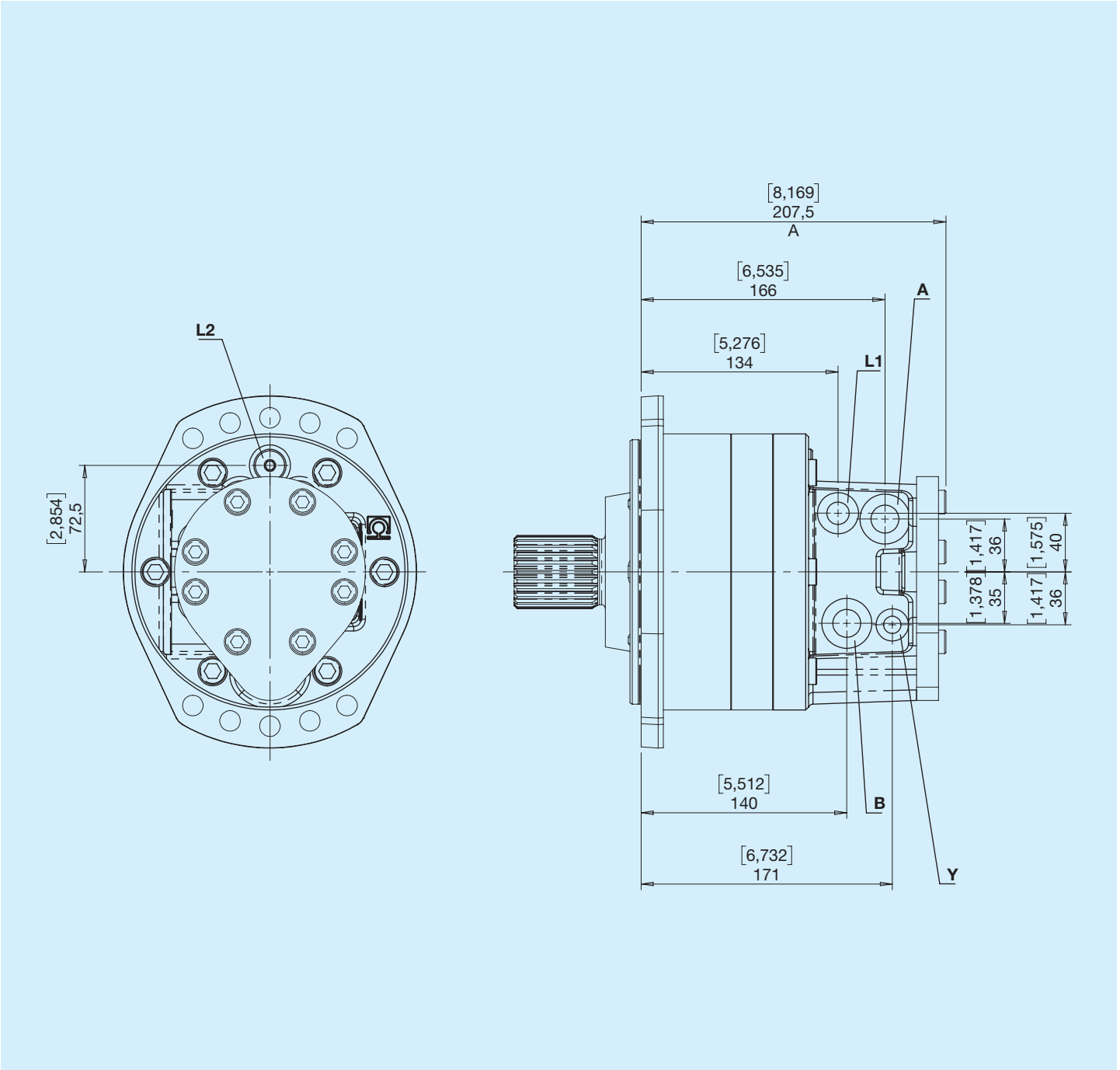

**WF** 2 档带制动

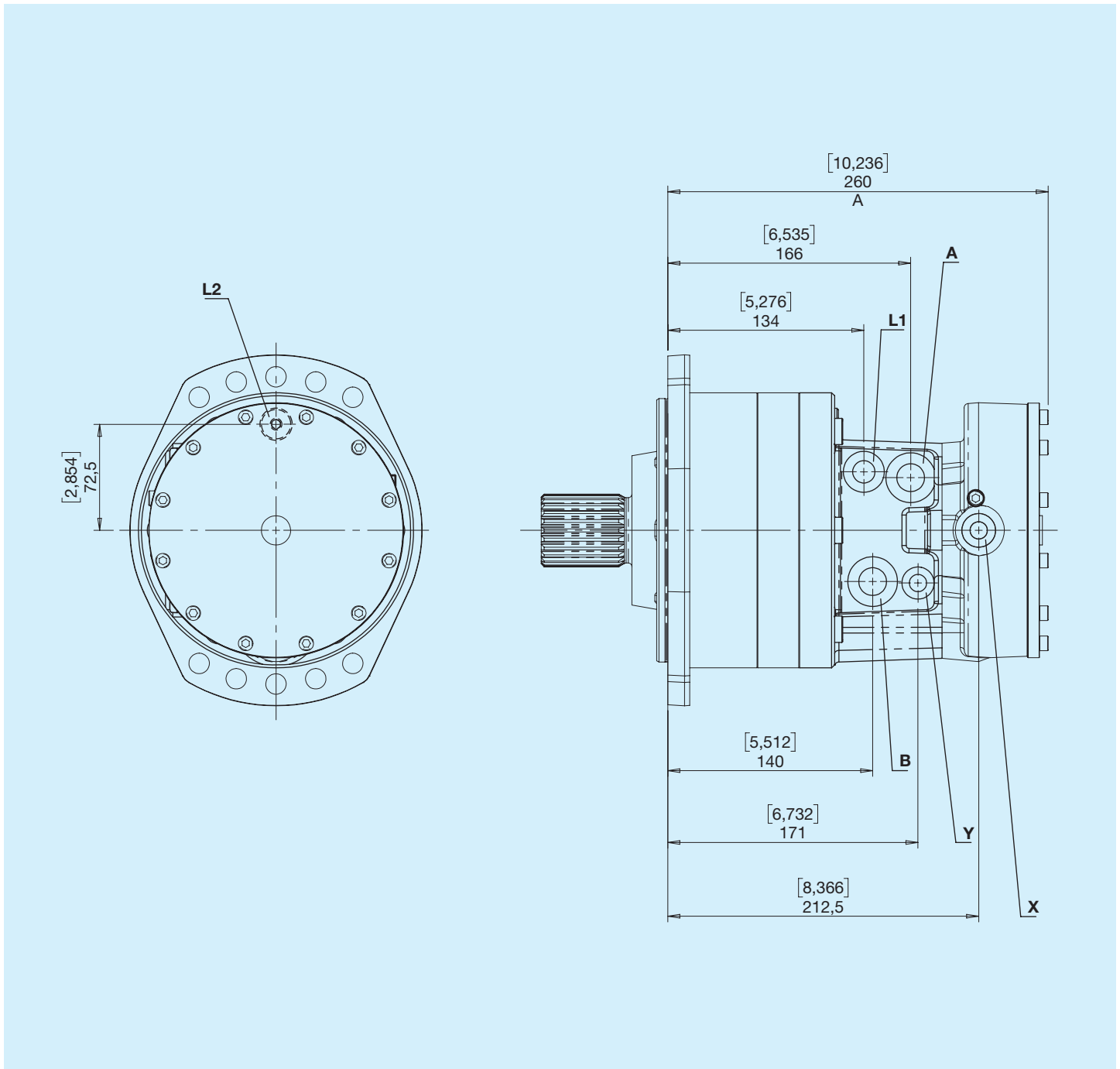

	1	2 3	4 5 6	7	8	9	10	11 12 13
<b>HPR</b>								
1	标准排量							
	<b>2</b>							
2 3	传动轴							
	<b>FB</b> 固定 - 双向		<b>VR</b> 可变 - 右			<b>VR</b> 可变 - 左		
4 5 6	最小排量							
	<b>210</b>		<b>260</b>			<b>360</b>		
	<b>230</b>		<b>330</b>			<b>400</b>		
7	法兰							
	<b>R</b> 后 (轮)		<b>1</b> 后 (带螺钉的轮子)		<b>2</b> 后 (带螺钉和螺母的轮子)		<b>E</b> 轴 DIN 5480 W50x2x30x24	
8	传动轴							
	<b>F</b> 带制动			<b>C</b> 不带制动				
9	油口类型							
	<b>G</b> 气体			<b>U</b> 通用				
10	配件							
	<b>0</b> 无选项		<b>C</b> 油漆		<b>V</b> 冲洗阀		<b>S</b> 转速传感器	
11 12 13	特殊形式							
	...							